

**DESALTO**

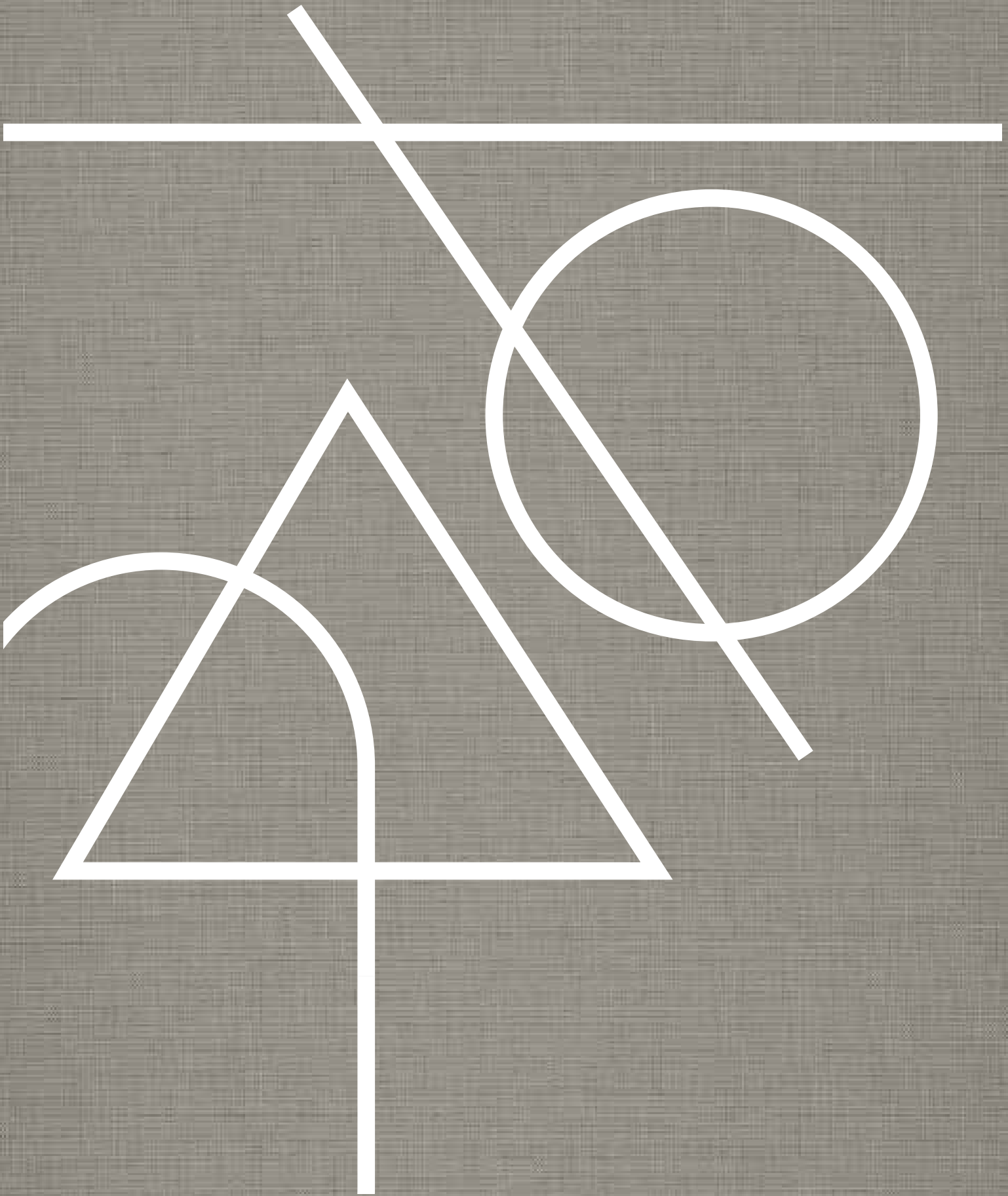

# catalogue

identity

overview	p. 004
intro	p. 008
designers	p. 010
awards	p. 014

catalog

#01 affinity	p. 016
#02 relation	p. 040
#03 essence	p. 072
#04 connection	p. 110
#05 continuity	p. 138
#06 multiplicity	p. 158
#07 appeal	p. 192
#08 consonance	p. 218
#09 in between	p. 246

<u>abaco</u>	p. 280
--------------	--------

# contents



**Armida**  
pp. 078/079, 080, 081,  
144, 145, 146/147  
p. 283



**Fill**  
pp. 096, 097, 098, 099,  
118/119, 120, 121, 136  
p. 284



**Hang**  
pp. 086/087, 090, 091  
p. 285

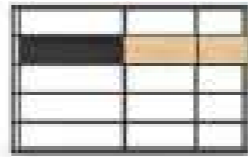

**Helsinki**  
pp. 038/039, 073, 074, 075,  
126/127, 130, 131  
p. 286



**Helsinki 35 office**  
pp. 052/053, 054, 148,  
149, 150, 151  
p. 306



**Helsinki 35 outdoor**  
p. 307



**Iblea**  
pp. 108, 230/231,  
232, 233  
p. 308



**Icaro 015**  
pp. 166/167, 169  
p. 309



**Mini Booxx**  
pp. 124, 125  
p. 287



**Sail**  
pp. 111, 112/113, 164, 165, 245  
p. 288/289



**Stac**  
pp. 160/161, 162, 163,  
174/175, 191  
p. 290



**Step**  
pp. 112/113, 114, 115  
p. 291



**Kobe**  
p. 310

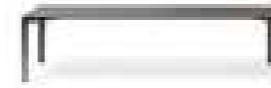

**L45**  
pp. 159, 160/161, 174/175, 176,  
177, 190, 193, 195  
p. 311



**Lake**  
pp. 236/237, 239  
p. 312



**Liko Glass**  
pp. 206/207, 208, 209, 215  
p. 313



**25**  
pp. 017, 018/019, 020, 021  
p. 292

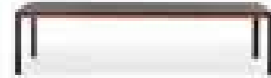

**Beam**  
pp. 107, 226/227, 228, 229  
p. 293

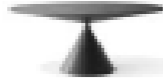

**Clay**  
pp. 070, 100/101, 102, 125,  
178/179, 180, 181, 265,  
268/269, 271, 273  
p. 294/295

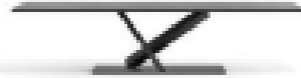

**Element**  
pp. 118/119, 123, 139,  
140/141, 143, 145  
p. 296/297



**Link**  
pp. 041, 042/043, 044,  
047, 048, 049  
p. 314/315



**Mac**  
pp. 086/087, 088, 089  
p. 316



**MM8**  
pp. 154/155, 219, 220/221,  
260/261, 263  
p. 317



**Skin**  
pp. 182/183, 184, 185  
p. 318



**Ellis**  
pp. 257, 258  
p. 298



**Every**  
p. 299



**Fan**  
pp. 026/027, 028, 029,  
092/093, 094, 095  
p. 300

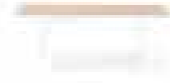

**Fourmore**  
pp. 170/171, 173  
p. 301



**Strong**  
pp. 137, 235  
p. 319

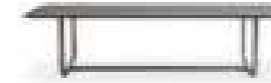

**Strong**  
pp. 060/061, 063,  
064, 156  
p. 320



**Tender**  
pp. 198/199, 200, 201  
p. 321



**288**  
p. 278  
p. 322

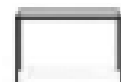

**Helsinki 30 home**  
p. 225  
p. 302



**Helsinki 30 extending**  
pp. 126/127, 129  
p. 303



**Helsinki 35 extending**  
pp. 252/253, 254, 255  
p. 304



**Helsinki 35 home**  
p. 097, 098, 297  
p. 305



**Aria**  
pp. 036, 078/079, 111,  
112/113  
p. 323



**Calum Office**  
pp. 041, 042/043, 044, 045,  
047, 048, 049, 050, 051,  
055, 188, 189  
p. 324/325



**Calum Home**  
pp. 252/253, 254, 256, 257,  
258, 259, 260/261,  
262, 263, 268/269, 271,  
272, 273  
p. 326



**Calum Lounge**  
pp. 022/023, 024, 025,  
052/053, 056/057, 058,  
202/203, 204, 205  
p. 327

# overview



**Endless**  
pp. 026/027, 030,  
031, 242  
p. 328



**Flan**  
p. 276  
p. 329



**Kobe**  
pp. 182/183, 184  
p. 330



**Koki**  
pp. 100/101, 102, 103,  
148/149, 160/161, 216  
p. 331



**Trace**  
pp. 033, 126/127, 129, 135  
p. 349



**Void**  
pp. 219, 220/221,  
222, 223  
p. 350



**Wok**  
pp. 196, 197  
p. 351



**Element**  
pp. 106, 146  
p. 352



**Koki Wire**  
pp. 206/207, 208, 209, 210,  
211, 243 / p 332  
**Koki Wire – cuoio**  
pp. 264/265, 266, 267 / p 333



**Lisbona**  
pp. 139, 140/141, 142, 143  
p. 334



**Mun**  
pp. 060/061, 063, 065,  
118/119, 122, 157,  
236/237, 239  
p. 335



**Myg**  
pp. 224, 225  
p. 336

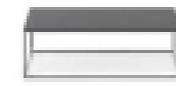

**Helsinki 15**  
pp. 078/079, 082,  
083, 204  
p. 353

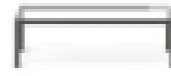

**Helsinki 30**  
p. 354

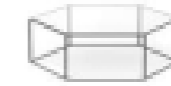

**Hexagon**  
pp. 078/079, 082, 083,  
085, 214  
p. 355



**Icaro O15**  
p. 356



**Nara**  
pp. 174/175, 176, 177,  
198/199, 201  
p. 337



**Paper**  
p. 338



**Ply**  
pp. 170/171, 172, 193, 194,  
195, 230/231, 233  
p. 339



**Riga**  
p. 277  
p. 340



**L45**  
p. 357



**Liko Glass**  
p. 358



**Mini Clay**  
pp. 022/023, 024,  
056/057, 059  
p. 359

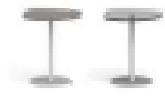

**Mixit + Mixit Glass**  
pp. 037, 202/203  
p. 360



**Sand**  
pp. 026/027, 029,  
086/087, 088  
p. 341



**Sand Air**  
p. 109  
p. 342



**Sand Light**  
pp. 017, 018/019,  
226/227, 229  
p. 343



**Softer than Steel**  
p. 071  
p. 344



**Softer than Steel**  
p. 079  
p. 361



**Void**  
pp. 069, 112/113, 166/167,  
222, 223  
p. 362



**Crown**  
p. 217  
p. 363



**Dadi**  
p. 364



**Softer than Steel**  
p. 068  
p. 345



**Strong**  
pp. 092/093, 166/167,  
168, 178/179, 180  
p. 346



**Strong Special**  
pp. 244, 247, 248/249,  
250, 251  
p. 347



**Strong**  
pp. 116, 117, 234, 235  
p. 348



**Helsinki**  
pp. 073, 076, 077  
p. 365



**Mir**  
p. 366



**Quartz**  
pp. 033, 134  
p. 367



**Softer than Steel**  
p. 368



**Unus**  
p. 125  
p. 369

Una storia in  
evoluzione, per l'abitare  
contemporaneo.  
Con la ricerca e il design  
al centro, sempre.

A story of  
contemporary living that  
continues to unfold,  
always focusing  
on research and design.



La sede: dalla ricerca  
e sviluppo fino alla produzione  
e alla vendita, un unico luogo  
dinamico e flessibile.

The headquarters:  
from research and development  
right down to production  
and sales, all in one single dynamic  
and flexible location.

intro

dad  
ca  
or  
tos  
d  
on  
ño  
bién  
des  
an  
ian  
es  
io  
n  
o,

# Una storia in

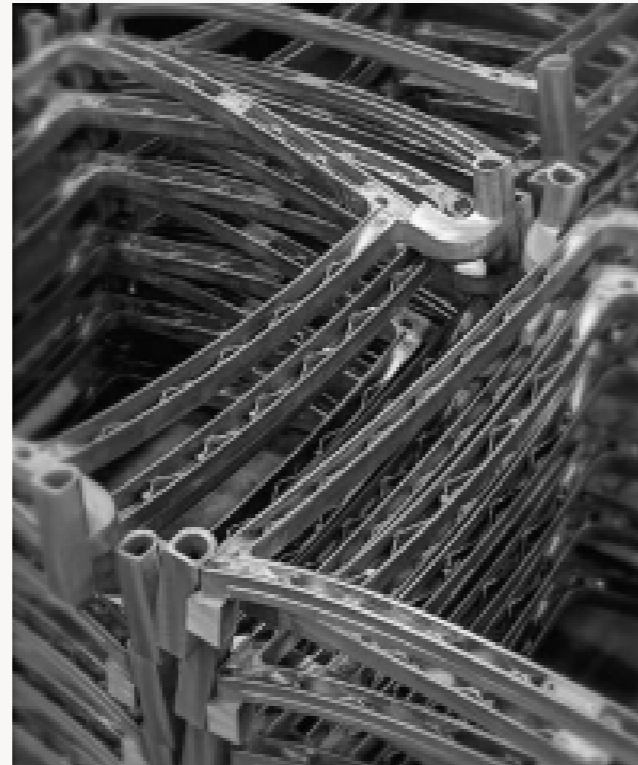

Desalto offre la sua sapienza tecnica e l'abilità dei suoi artigiani alla creatività dei protagonisti del design. Tutte le lavorazioni si svolgono all'interno dello stabilimento, a garanzia di qualità e di controllo su ogni processo.

Desalto offers its technical expertise and the skill of its artisans to the creativity of leading names in design. All production processes are carried out inside the plant, guaranteeing the quality and control of each and every phase.

it — Il nuovo catalogo Desalto invita a esplorare un'idea dell'abitare

de — Der neue Katalog von Desalto ist eine Einladung neue

es — El nuevo catálogo Desalto invita a explorar una idea de habitar



dad  
ca  
or  
tos  
d  
on  
ño  
bién  
des  
an  
ian  
es  
io  
n  
o,

Una storia in

it — Il nuovo catalogo Desalto  
invita a esplorare un'idea dell'abitare

de — Der neue Katalog von  
Desalto ist eine Einladung neue

es — El nuevo catálogo Desalto  
invita a explorar una idea de habitar



L'impianto galvanico, fiore all'occhiello dell'azienda: grazie ad attente lavorazioni, si ottengono tutte le esclusive finiture Desalto.

The galvanising department is the company's pride and joy: all of Desalto exclusive finishes are achieved thanks to careful production processes.

dad  
ca  
or  
tos  
d  
on  
ño  
bién  
des  
an  
ian  
es  
io  
n  
o,



# Una storia in



it — Il nuovo catalogo Desalto  
invita a esplorare un'idea dell'abitare

de — Der neue Katalog von  
Desalto ist eine Einladung neue

es — El nuevo catálogo Desalto  
invita a explorar una idea de habitar



Operazioni minuziose,  
fondamentali per il design di alta  
qualità. Come la saldatura e il taglio  
laser, la cui precisione permette  
di ottenere quei dettagli unici che  
sono cifra distintiva degli arredi  
Desalto.

Meticulous workmanship,  
fundamental to high quality design.  
The precision of our welding and  
laser cutting enables us to achieve  
the unique details that are the  
hallmark of Desalto furnishings.

dad  
ca  
or  
tos  
d  
on  
ño  
bién  
des  
an  
ian  
es  
io  
n  
o,

Una storia in

it — Il nuovo catalogo Desalto  
invita a esplorare un'idea dell'abitare

de — Der neue Katalog von  
Desalto ist eine Einladung neue

es — El nuevo catálogo Desalto  
invita a explorar una idea de habitar

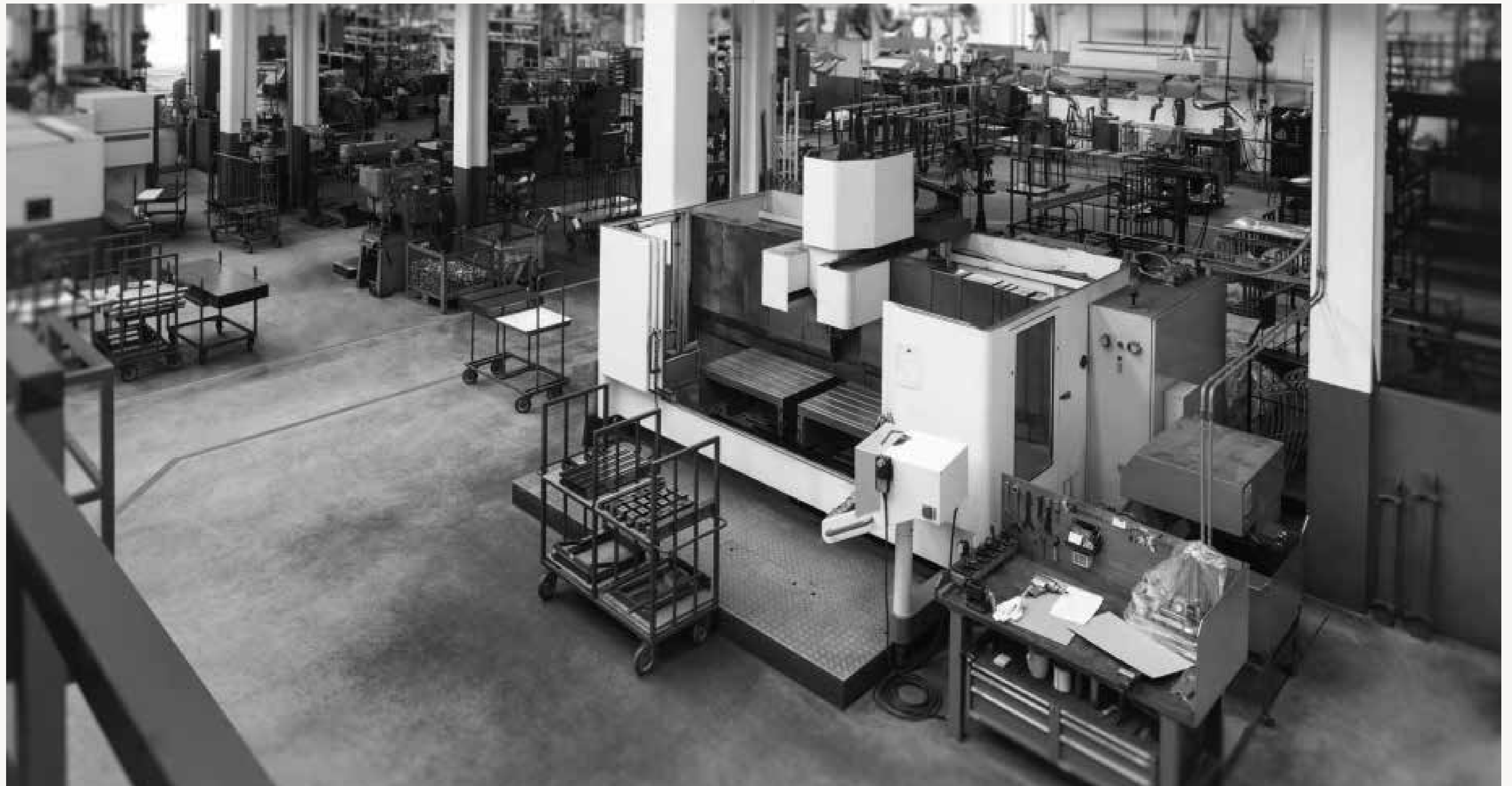

I reparti produttivi: tecnologie d'avanguardia, esperienza e sapienza produttiva, insieme, in una struttura ampia e funzionale.

The production departments: cutting-edge technology, experience and expertise in production, together, in one large, functional plant.

dad  
ca  
or  
tos  
d  
on  
ño  
bién  
des  
an  
ian  
es  
io  
n  
o,

# Una storia in

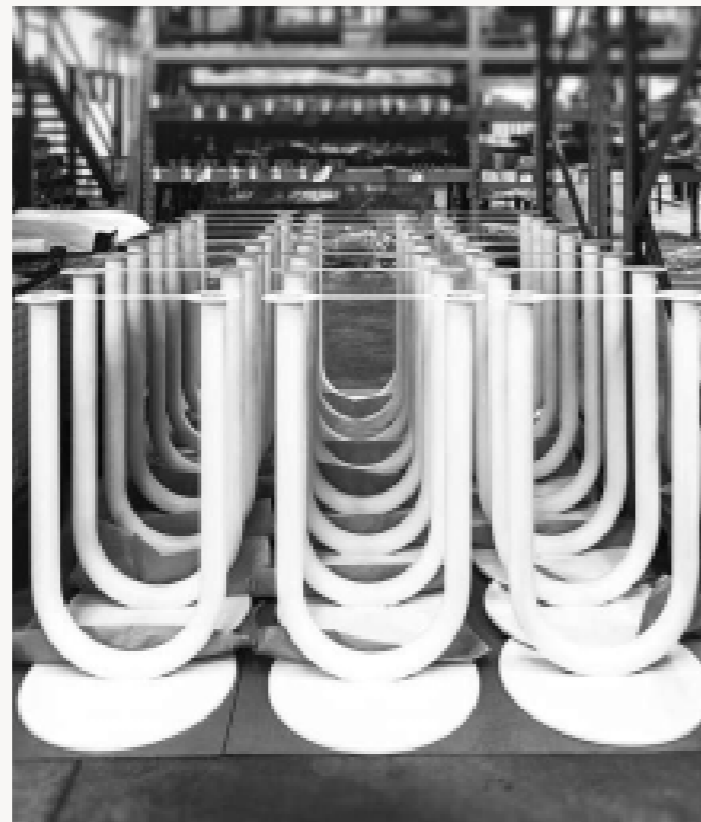

Il metallo e le sue lavorazioni sono il cuore della produzione: abilità artigiane e alto contenuto tecnologico al servizio del design, per elevati standard qualitativi.

Metal and its processing are the heart of our production: skilled craftsmanship and high technological content at the service of design, for high standards of quality.

it — Il nuovo catalogo Desalto invita a esplorare un'idea dell'abitare

de — Der neue Katalog von Desalto ist eine Einladung neue

es — El nuevo catálogo Desalto invita a explorar una idea de habitar

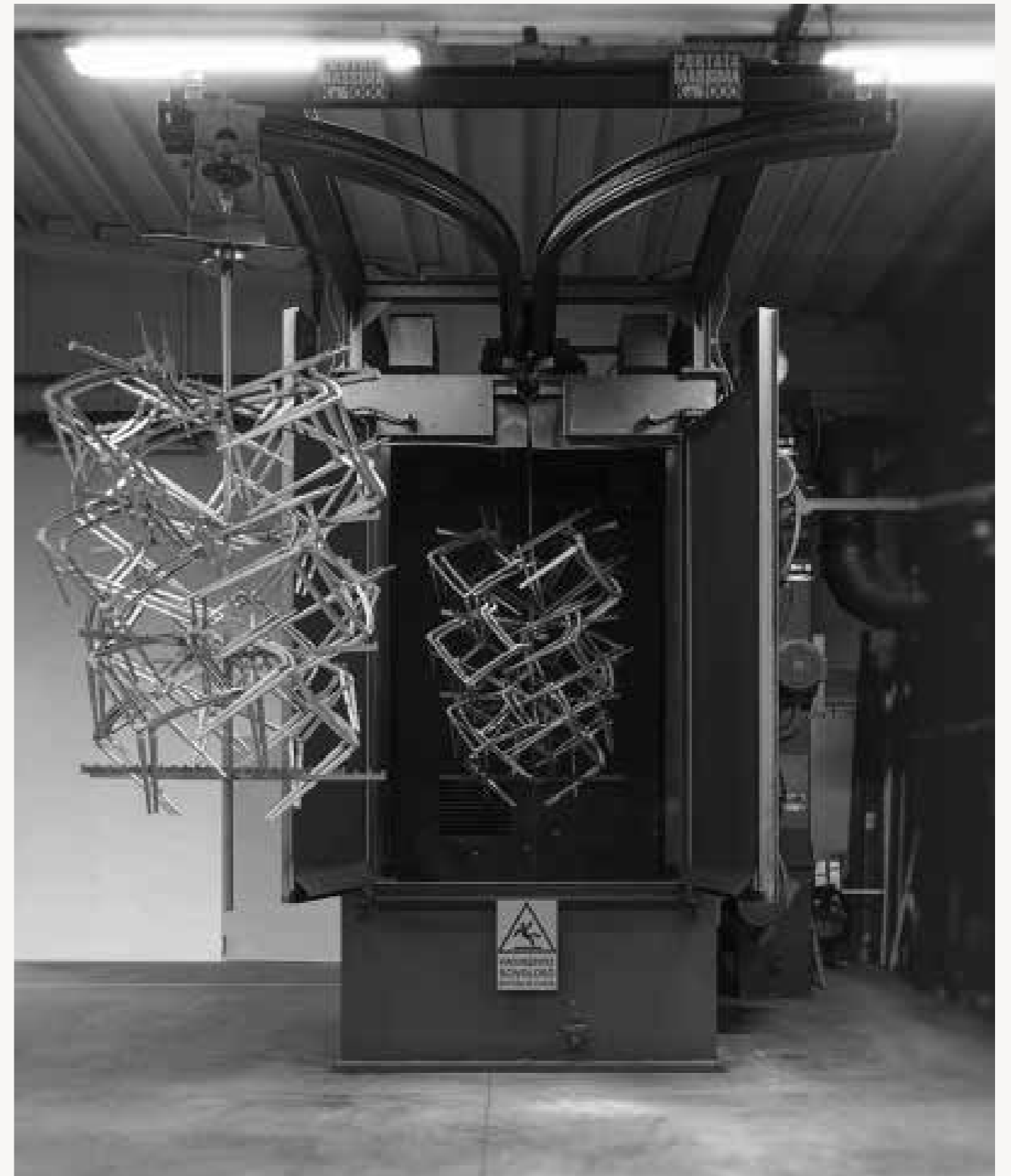

dad  
ca  
or  
tos  
d  
on  
ño  
bién  
des  
an  
ian  
es  
io  
n  
o,

## Una storia in



Lo showroom aziendale: uno spazio fluido e accogliente, concepito per esporre i prodotti Desalto in allestimenti sempre diversi e in dialogo con opere che sono espressioni di altre arti, come dipinti, arazzi e ceramiche.



The company showroom: a fluid, inviting space, conceived to display Desalto products in a range of different settings, conversing with other artworks such as paintings, tapestries and ceramics.

## concept

**it** — Il nuovo catalogo Desalto invita a esplorare un'idea dell'abitare, a vivere la casa e gli spazi del lavoro al meglio e con stile, ogni giorno, grazie alla versatilità di arredi dal carattere distintivo e raffinato.

Questo volume raccoglie e racconta ambienti unici e accoglienti, luoghi molto diversi animati dall'incisiva presenza dei prodotti Desalto. Trasversalità, flessibilità, contaminazione: peculiarità che sono valori, modi di concepire il design, lo spazio e, di riflesso, il modo di vivere gli ambienti. Luoghi aperti ed eclettici che rispecchiano personalità ed esigenze, che accolgono e assecondano funzioni, che contengono e valorizzano storie in cui il ruolo dei prodotti Desalto è essere interpreti polivalenti. Per continuare un percorso coerente e sempre in sintonia con valori che parlano del miglior design: l'attenzione al progetto e la cultura del fatto bene.

**en** — The new Desalto catalogue invites you to explore an idea of living, for a better and more stylish daily experience of the home and the workplace, thanks to the versatility of distinctive, elegant furnishings.

This volume brings together and talk about unique, comfortable spaces, very different places enlivened by the unmistakable presence of Desalto products. Transversality, flexibility, cross contamination: these are valuable characteristics, ways of conceiving the design and space, thus a proper way of living. Open and eclectic places that reflect different personalities and needs, that embrace and adapt to functions, that contain and enhance stories in which Desalto products play a variety of roles. Continuing along a pathway that closely follows the values of fine design, paying attention to the concept and the culture of superior workmanship.

**de** — Der neue Katalog von Desalto ist eine Einladung neue Wohnideen zu entdecken, um eine Wohnung und Arbeitsräume an jedem Tag auf beste Weise und stilvoll zu nutzen: dank der Vielseitigkeit der charakteristischen, exklusiven Möbel.

Dieser Katalog zeigt Wohnlösungen und erzählt von ihrer Eigenart und Gemütlichkeit, von sehr unterschiedlichen Räumen, die von der entscheidenden Präsenz von Desalto-Möbeln geprägt sind. Bereichsübergreifend, vielseitig, ansteckend. Besonderheiten, die Werte erzeugen, Konzepte von Design und Raum, also eine andere Art, ein Ambiente zu erleben. Offene, vielschichtige Orte, die Persönlichkeit und Bedürfnisse widerspiegeln, Funktionen aufnehmen und unterstützen, Diese Räumlichkeiten erzählen Geschichten in denen die Möbel von Desalto die wandlungsfähigen Interpreten sind und sie zu idealer Geltung bringen, Dies alles dient dazu unseren Weg konsequent weiterzugehen, stets im Einklang mit einem hochwertigen Design: sensiblen Planungen und einer Kultur der guten Arbeitsausführung.

**fr** — Le nouveau catalogue Desalto invite à explorer une idée de l'habitat, à vivre la maison et les espaces de travail dans les tendances actuelles et avec style, chaque jour, grâce à la polyvalence de meubles raffinés et d'un grand tempérament.

Ce volume réunit et parle d'espaces uniques et accueillants, de lieux très différents animés par la présence incisive des produits Desalto. Transversalité, flexibilité, fusion avec transmissions : des particularités qui sont des valeurs, des manières de concevoir le design, l'espace et, par conséquent, la manière de vivre les pièces. Des lieux ouverts et éclectiques qui reflètent les personnalités et les besoins, qui accueillent et soutiennent des fonctions, qui contiennent et valorisent des histoires dans lesquelles le rôle des produits Desalto est d'être des interprètes polyvalents. Pour continuer un parcours cohérent et toujours en harmonie avec des valeurs qui parlent du meilleur design : l'attention pour le projet et la culture des choses bien faites.

**es** — El nuevo catálogo Desalto invita a explorar una idea de habitar y de vivir cada día el hogar y los espacios de trabajo con estilo y de la mejor forma, gracias a la versatilidad de sus muebles con un carácter distinguido y refinado.

Este volumen recopila y explica ambientes únicos y acogedores, lugares muy diferentes animados por la presencia incisiva de los productos Desalto. Transversalidad, flexibilidad y fusión, tres peculiaridades que son valores, formas de concebir el diseño y el espacio y, como resultado, también la manera de vivir los ambientes. Se trata de lugares abiertos y eclécticos que reflejan personalidades y necesidades, que acogen y apoyan funciones, que contienen y potencian historias en las que el papel de los productos Desalto es ser intérpretes polivalentes; para seguir un itinerario coherente y siempre en sintonía con valores que hablan del mejor diseño, es decir, de la atención al proyecto y la cultura del hacer bien.

Progettisti di talento, selezionati con cura, contribuiscono ad arricchire la collezione dei prodotti, tra innovazione formale, creatività e sperimentazione.

Talented, carefully selected designers contribute towards enriching the collection with new products, a combination of formal innovation, creativity and experimentation.



Arik Levy  
Endless, Quarz, Liko Glass, Mixit + Mixit Glass



Atelier Oï  
Aria



Caronni + Bonanomi  
Armida, Helsinki collection, Every, Sail, Icaro O15, Sail

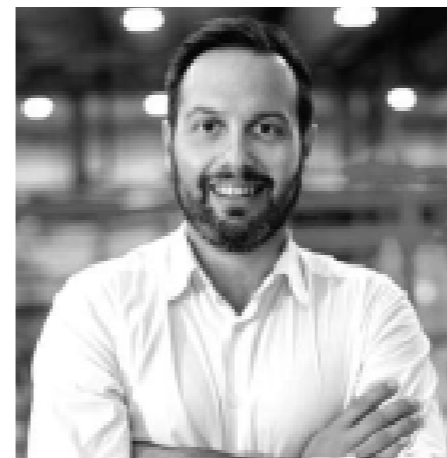

Cristian Gori  
Paper



Claudio Caramel  
Hang



Decoma Design  
Tender



Denis Santachiara  
Mini Boxx

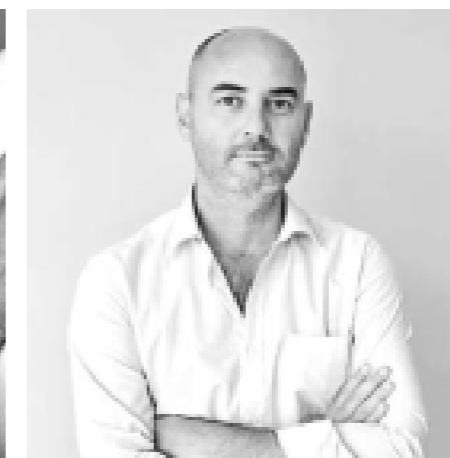

Eugeni Quitllet  
Strong collection, Strong Special



Giacomo Moor  
Stac

# designers

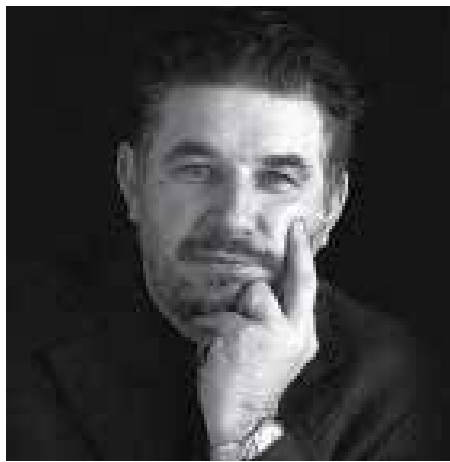

Gianluigi Landoni  
Dadi



Gordon Guillaumier  
Fourmore, Iblea, Lake



Guglielmo Poletti  
L45, Void, MM8

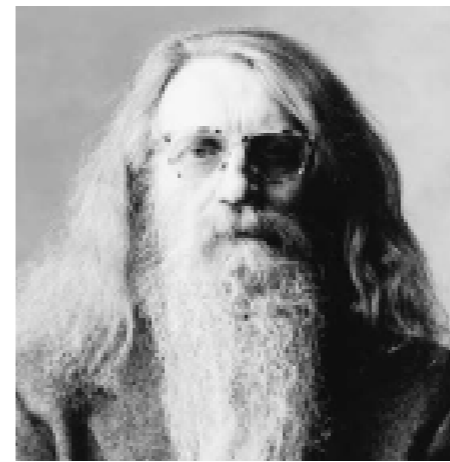

Piergiorgio Cazzaniga  
Kobe, Nara



Pierluigi Cerri  
Mac

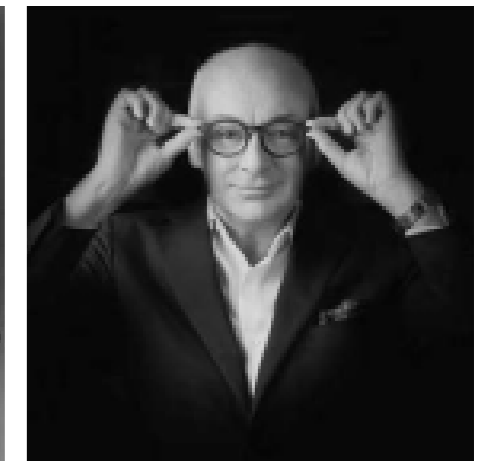

Piero Lissoni  
Fan



Hannes Wettstein  
Link



Marc Krusin  
Clay, Mini Clay



Marco Acerbis  
Mir, Skin



Pocci + Dondoli  
288, Ellis, Koki, Koki Wire, Riga +  
Lisbona, Ply, Sand, Sand Air, Sand  
Light, Flan, Wok



Shin Azumi  
Trace



Simon Pengelly  
Calum collection



Mario Ferrarini  
Beam, Myg, Mun



Metrica  
(Bruno Fattorini + Robin Rizzini)  
25



Nendo  
Softer than Steel, Step

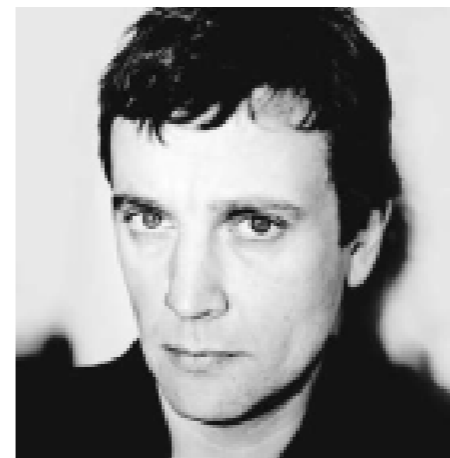

Stefan Schöning  
Crown



Studio Ausenda Greco  
Fill



Tokujin Yoshioka  
Element, Hexagon

Prestigiosi premi e riconoscimenti internazionali testimoniano la qualità e l'alto valore estetico e tecnologico dei prodotti Desalto.

Prestigious international awards and accolades stand as a testament to the quality and the high aesthetic and technological value of Desalto products.

	Collezione permanente MoMA, New York		Interior Innovation Award
2010	<u>Entronauta</u>	2016	<u>Clay</u>
		2015	<u>Fan</u>
		2014	<u>Element</u> , Winner
	XXIII Compasso d'Oro ADI	2012	<u>Kobe</u> , Winner
2014	<u>25</u>	2012	<u>25</u> , Best of the Best
		2011	<u>Sand Light</u> , Winner
	Menzione d'onore Compasso d'Oro ADI	2006	<u>Helsinki XL</u> , Best Detail
2016	<u>Element</u>	2005	<u>4to8</u> , Best Detail
2016	<u>Softer than Steel</u>	2005	<u>Liko Gass</u> , Best Detail
2011	<u>Entronauta</u>	2004	<u>Tender</u> , Class Innovation
		2003	<u>Liko</u> , Best Item
	Archiproducts Design Awards		Travel + Leisure Design Award
2021	<u>Koki Wire</u> , Winner	2014	<u>Element</u> , Best Retail Space
2019	<u>Strong</u> , Winner		Issey Miyake Tokyo
2018	<u>Lake</u> , Winner		Showroom
	Elle Deco International Design Awards		Good Design Award, Chicago Athaeneum
2013	<u>Element</u> , Best in Furniture	2016	<u>Clay</u>
	Stylepark Selected Award		Reddot design Award
2020	<u>Strong</u> , imm 2020	2016	<u>Clay</u>
		2009	<u>Kobe</u>
	Muuz International Awards		Palmarès / Archi Design Club
2020	<u>Stac</u>	2013	<u>Element</u>
2015	<u>Softer than Steel</u>		
	Young & Design		
2005	<u>Compasso</u>		
1996	<u>Zip</u>		
1991	<u>Bibop</u>		
1990	<u>Tender</u>		
	Wallpaper Design Award		
2020	<u>Void</u>		
2014	<u>Element</u> , Best Line Work		
2009	<u>Fluid</u>		



desalto collections

Modulare  
lo spazio domestico,  
abitare con cura  
il proprio mondo.

Modulating  
your own home, and  
living it with care.

affinity

setting #01





25 — tavolo / table  
design Metrica  
(Bruno Fattorini + Robin Rizzini)  
2011

Sand Light — sedia / chair  
design Pocci + Dondoli  
2010



Sand Light — sedia  
struttura: B41 tortora  
seduta: S30 canatex

Sand Light — chair  
frame: B41 tortora  
seat: S30 canatex



25 – tavolo  
struttura: D58 cemento ghiaccio

25 – table  
frame: D58 ghiaccio concrete

Calum Lounge – Relax+Pouf  
design Simon Pengelly  
2022

Mini Clay – tavolino  
/ small table  
design Marc Krusin  
2016





Calum Lounge – Relax  
struttura: B42 grafite  
seduta: network H92 pernice

Calum Lounge – Relax  
frame: B42 grafite  
seat: network H92 pernice

Mini Clay – tavolino  
struttura: D56 cemento ardesia

Mini Clay – small table  
frame: D56 ardesia concrete

Fan — tavolo / table  
design Piero Lissoni  
2014

Sand — sedia / chair  
design Pocci + Dondoli  
2002

Endless — sgabello / stool  
design Arik Levy  
2017





Fan — tavolo  
struttura: B59 nero opaco  
top: D60 cemento rosso mattone

Fan — table  
frame: B59 matt black  
top: D60 matt red concrete

Sand — sedia  
struttura: B59 nero opaco  
seduta: softy H37 nocciola

Sand — chair  
frame: B59 matt black  
seat: softy H37 nocciola





Endless – sgabello / stool  
design Arik Levy  
2017

Endless – sgabello  
struttura: A27 titanium  
seduta: cuoio Q14 brandy

Endless – stool  
frame: A27 titanium  
seat: cowhide Q14 brandy





Void — sgabello+console  
/ stool+console  
design Guglielmo Poletti  
2019

A74 ferro naturale  
/ A74 natural iron

Quartz — specchio / mirror  
design Arik Levy  
2018



it — La luce naturale come protagonista, dall'esterno all'interno. Una grande casa al lago fa dell'essenzialità un manifesto: tra geometrie ed elementi dai profili sottili, tutto dialoga nello spazio per enfatizzare un desiderio di rigore e di razionalità. Nell'intimità del silenzio domestico, con lo sguardo a un possibile infinito.

en — Natural light as the protagonist, from outside to inside. A large house by the lake makes a statement of simplicity: between geometries and slender elements, everything converses within the space to highlight a desire for rigour and rationality. In the intimacy of domestic silence, gazing at a possible infinity.

de — Tageslicht ist das entscheidende Element, von außen nach innen. Ein großes Haus am See macht Minimalismus zu seinem Bekenntnis: Schlanke Geometrien und Profile führen einen Dialog mit dem Raum und unterstreichen den Wunsch nach rigoroser Strenge und Rationalität. In der Intimität häuslicher Stille, mit dem Blick in eine unbegrenzte Ferne.

fr — La lumière naturelle comme élément principal, de l'extérieur vers l'intérieur. Une grande maison au bord du lac fait de l'essentiel un manifeste : entre les géométries et les éléments aux profils affinés, un dialogue dans l'espace pour mettre en valeur une envie de rigueur et de rationalité. Dans l'intimité du silence domestique, avec le regard tourné vers un possible infini.

es — La luz natural como protagonista, de fuera hacia dentro. Una gran casa sobre el lago transforma la esencialidad en un manifesto. Entre geometrías y elementos con perfiles finos, todo dialoga en el espacio para enfatizar un deseo de rigor y racionalidad. En la intimidad del silencio doméstico, con la mirada hacia un posible infinito.



Aria — poltrona  
/ lounge chair  
design Atelier Oï  
2019



Mixit — tavolini  
/ small tables  
design Arik Levy  
2005

Helsinki — libreria  
/ bookcase  
design Caronni + Bonanomi  
2009





desalto collections

Lavorare  
e sentirsi accolti  
dall'ambiente  
e dai suoi elementi,  
nel bello.

Working  
and feeling at home  
in the setting  
and its elements,  
in beauty.

relation

setting #02



r

Link — tavolo / table  
design Hannes Wettstein  
2000

Calum Office — Task  
design Simon Pengelly  
2022





Link – tavolo  
struttura: B42 grafite  
top: E65 cristallo grigio europa

Link – table  
frame: B42 grafite  
top: E65 grey europa glass

Calum Office – Task  
struttura: B42 grafite  
seduta: network H96 silicio

Calum Office – Task  
frame: B42 grafite  
seat: network H96 silicio







Link – tavolo / table  
design Hannes Wettstein  
2000

Calum Office – Task  
design Simon Pengelly  
2022



Calum Office – Task  
struttura: B62 bianco  
seduta: highland I51 peonia

Calum Office – Task  
frame: B62 white  
seat: highland I51 peonia



Link – tavolo  
struttura: B62 bianco  
top: E71 cristallo extrachiaro

Link – table  
frame: B62 white  
top: E71 extraclear glass





Calum Office – Task  
struttura: B62 bianco  
seduta: network H90 avorio

Calum Office – Task  
frame: B62 white  
seat: network H90 avorio



Helsinki 35 office — tavolo  
/ table  
design Caronni + Bonanomi  
1995

Calum Lounge — Relax  
design Simon Pengelly  
2022

Calum Lounge — Relax  
struttura: B82 grigio  
seduta: highland I50 lino

Calum Lounge — Relax  
frame: B82 grigio  
seat: highland I50 lino





Helsinki 35 office — tavolo  
struttura: B70 rosso lampone  
top: D89 ceramica amber

Helsinki 35 office — table  
frame: B70 lampone red  
top: D89 amber ceramic



Calum Office — President  
struttura: B82 grigio  
seduta: highland I50 lino

Calum Office — President  
frame: B82 grey  
seat: highland I50 lino

Calum Lounge – Relax  
design Simon Pengelly  
2022

Mini Clay – tavolino  
/ small table  
design Marc Krusin  
2016



Calum Lounge — Relax  
struttura: B62 bianco  
seduta: network H91 pomice

Calum Lounge — Relax  
frame: B62 white  
seat: network H91 pomice



Mini Clay — tavolino  
struttura: D58 cemento ghiaccio

Mini Clay — small table  
frame: D58 ghiaccio concrete

Strong — tavolo / table  
design Eugeni Quitllet  
2019

Mun — sedia / chair  
design Mario Ferrarini  
2019





Strong — tavolo  
struttura: A27 titanium  
top: D59 cemento cacao

Strong — table  
frame: A27 titanium  
top: D59 cacao concrete





Mun – sedia  
struttura: A27 titanium  
seduta: pelle M52 testa di moro

Mun – chair  
frame: A27 titanium  
seat: leather M52 testa di moro



setting #02

it – La memoria della storia e il suo ricordo, tutto intorno. Un palazzo storico accoglie e definisce uno spazio di lavoro dall'atmosfera calda e affascinante, favorita dall'incontro e dall'integrazione di materiali, di volumi, di tracce. In equilibrio tra il mondo di ieri e quello di oggi, vivere il piacere di un luogo inaspettato.

en – The memory of history and its recollections, all around you. A historical building houses and defines a working space with a warm, alluring atmosphere, created by the combination and integration of materials, volumes, lines. Balanced between the world of yesterday and of today, experiencing the pleasure of an unexpected setting.

de – Spuren der Vergangenheit und ihre Erinnerung überall. Ein historisches Gebäude nimmt diesen Arbeitsraum auf und definiert ihn in seiner warmen, reizvollen Atmosphäre, die durch das Miteinander und die Integration von Materialien, Volumen und historischen Spuren betont wird. Die Welt von gestern und heute in voller Harmonie: Es ist schön an einem Ort der Überraschungen zu leben.

fr – La mémoire de l'histoire et son souvenir, tout autour. Une demeure historique accueille et définit un espace de travail à l'atmosphère chaude et fascinante, favorisée par la rencontre et par l'intégration de matériaux, de volumes, de lignes. En équilibre entre le monde d'hier et celui d'aujourd'hui, pour vivre le plaisir d'un lieu inattendu.

es – La memoria de la historia y su recuerdo, por todas partes. Un edificio histórico recibe y define un espacio de trabajo con una atmósfera cálida y fascinante, favorecida por el encuentro y la integración de materiales, volúmenes y huellas. Vivir el placer de un lugar inesperado, en equilibrio entre el mundo de ayer y el de hoy.

Softer than Steel  
— panca / bench  
design Nendo  
2014



Void — console  
design Guglielmo Poletti  
2019



Clay – tavolo / table  
design Marc Krusin  
2015



Softer than Steel  
– sedia / chair  
design Nendo  
2014



desalto collections

La casa  
come attenta custode  
di storie, di riti,  
di tempi, di emozioni.

The home as  
a devoted guardian  
of stories, rituals,  
rhythms and emotions.



essence

setting #03





Helsinki — libreria / bookcase  
design Caronni + Bonanomi  
2009

struttura: B22 marrone bungee  
/ frame: B22 bungee brown







Helsinki — carrello / trolley  
design Caronni + Bonanomi  
1998

Helsinki — carrello  
struttura+top: B73 rosa quarzo

Helsinki — trolley  
frame+top: B73 rosa quarzo



Aria — lounge chair  
+pouf  
design Atelier Oï  
2019

seduta: S14 corallo  
/ seat: S14 corallo

Hexagon — tavolino  
/ small table  
design Tokujin Yoshioka  
2013

Helsinki 15 — tavolino  
/ small table  
Caronni + Bonanomi  
2014

Armida — sistema  
/ system  
Caronni + Bonanomi  
1997





Armida — sistema  
struttura: B59 nero opaco

Armida — system  
frame: B59 matt black





Hexagon – tavolino  
struttura: A18 ossidiana opaco  
top: E65 cristallo grigio europa

Hexagon – small table  
frame: A18 matt ossidiana  
top: E65 grey europa glass



Helsinki 15 – tavolino  
struttura: A18 ossidiana opaco  
top: E40 cristallo grafite opaco

Helsinki 15 – small table  
frame: A18 matt ossidiana  
top: E40 matt grafite glass



Hexagon — tavolino / small table  
design Tokujin Yoshioka  
2013

Mac — tavolo / table  
design Pierluigi Cerri  
2007

Sand — sedia / chair  
design Pocci + Dondoli  
2002

Hang — sistema / system  
design Claudio Caramel  
2008





Mac – tavolo  
struttura: B42 grafite  
top: D87 ceramica lava

Mac – table  
frame: B42 grafite  
top: D87 lava ceramic

Sand – sedia  
struttura: A27 titanium  
seduta: S28 grigio ghisa

Sand – chair  
frame: A27 titanium  
seat: S28 ghisa grey



Hang – sistema  
struttura: B70 rosso lampone

Hang – system  
frame: B70 lampone red







Fan — tavolo / table  
design Piero Lissoni  
2014

Strong — sedia / chair  
design Eugeni Quitllet  
2019



Fan – tavolo  
struttura: A74 ferro naturale  
top: C60 rovere naturale segato

Fan – table  
frame: A74 natural iron  
top: C60 swan natural oak

Strong – sedia  
struttura: B81 curry  
rivestimento: messenger T90 senape

Strong – chair  
frame: B81 curry  
covering: messenger T90 senape



Fill — sistema / system  
design Studio Ausenda Greco  
2008

Helsinki 35 home — tavolo / table  
design Caronni + Bonanomi  
1995





Fill — sistema  
struttura: B13 sabbia

Fill — system  
frame: B13 sabbia

Helsinki 35 home — tavolo  
struttura: B13 sabbia  
top: D84 bianco calce

Helsinki 35 home — table  
frame: B13 sabbia  
top: D84 calce white

Clay — tavolo / table  
design Marc Krusin  
2015

Koki — sedia / chair  
design Pocci + Dondoli  
2015





Clay – tavolo  
struttura: D61 cemento bianco

Clay – table  
frame: D61 white concrete

Koki – sedia  
struttura: B22 marrone bungee  
seduta: F73 marrone bungee

Koki – chair  
frame: B22 bungee brown  
seat: F73 bungee brown





setting #03

it – La funzione e il decoro, il colore e il calore. La personalità di una dimora emerge e comunica, espressiva e invitante. E così uno spazio rurale si fa vivace e sofisticatamente solare, con arredi dagli accenti cromatici marcati in dialogo con materiali della contemporaneità, declinati nella loro natura più sincera.

en – Function, decoration, colour and warmth. The personality of a home emerges and speaks, expressive and inviting. And so a rural space becomes vibrant, sophisticated and cheerful, with furnishings with details in strong colours conversing with contemporary materials in their purest form.

de – Funktion und Zierde, Farbe und Wärme. Die Persönlichkeit des Hauses tritt hervor und spricht, ausdrucksstark und einladend. So wird ein ländlicher Raum lebendig und von strahlender Raffinesse, mit Möbeln, die starke, farbliche Akzente im Dialog mit modernen Materialien setzen, die sich in ihrer sehr ursprünglichen Natur darbieten.

fr – La fonction et le décor, la couleur et la chaleur. La personnalité d'une maison émerge et communique, expressive et invitante. Ainsi, un espace rural devient vivant et élégamment solaire, avec des meubles aux accents chromatiques marqués qui dialoguent avec des matériaux contemporains, déclinés dans leur nature la plus sincère.

es – La función y la decoración, el color y el calor. La personalidad de un hogar emerge y comunica, expresiva y atractiva. De esta forma, un espacio rural se vuelve dinámico y sofisticadamente soleado, con mobiliario de tonos cromáticos marcados que dialogan con materiales contemporáneos, declinados en su más sincera naturaleza.

Element — tavolino / small table  
design Tokujin Yoshioka  
2013



Beam — tavolo / table  
design Mario Ferrarini  
2018







Iblea — tavolo / table  
design Gordon Guillaumier  
2007

Sand Air — sedia / chair  
design Poggi + Dondoli  
2003





connection

Interni articolati e vitali, come progetti appassionati e in divenire.

Varied and vital interiors, exciting designs in the making.



setting #04





Step – sistema / system  
design Nendo  
2019

Void – tavolino / small table  
design Guglielmo Poletti  
2019

Aria – lounge chair  
design Atelier Oï  
2019

Sail 304 – sistema / system  
design Caronni + Bonanomi  
2013





Step — sistema / system  
design Nendo  
2019

Step — sistema  
struttura: B59 nero opaco

Step — system  
frame: B59 matt black





**Strong** — sgabello / stool  
design Eugeni Quitllet  
2019

struttura: B59 nero  
seduta: C14 rovere laccato nero

frame: B59 black  
seat: C14 black lacquered oak



Element — tavolo / table  
design Tokujin Yoshioka  
2013

Mun — sedia / chair  
design Mario Ferrarini  
2019





Fill — sistema  
struttura: B13 sabbia



Fill — system  
frame: B13 sabbia



Fill — sistema / system  
design Studio Ausenda Greco  
2008





Mun – sedia  
struttura: B13 sabbia  
rivestimento: softy H28 cipria

Mun – chair  
frame: B13 sabbia  
covering: softy H28 cipria



Element – tavolo  
struttura: D60 cemento rosso mattone

Element – table  
frame: D60 mattone red concrete



Mini Boox — sistema / system  
design Denis Santachiara  
2006

struttura: B81 curry  
/ frame: B81 curry

Clay — tavolo / table  
design Marc Krusin  
2015

struttura: D57 cemento ocra  
/ frame: D57 ocra concrete

Unus — complemento  
/ complement  
design Elisa Ossino  
2014

struttura: D61 cemento bianco  
/ frame: D61 white concrete



Helsinki 30 extending  
— tavolo / table  
design Caronni + Bonanomi  
1995

Trace — sedia / chair  
design Shin Azumi  
2005

Helsinki — libreria  
/ bookcase  
design Caronni + Bonanomi  
2009



Trace — sedia  
struttura: B42 grafite  
seduta: B42 grafite

Trace — chair  
frame: B42 grafite  
seat: B42 grafite

Helsinki 30 extending — tavolo  
struttura: B42 grafite  
top: C68 rovere moro

Helsinki 30 extending — table  
frame: B42 grafite  
top: C68 moro oak





Helsinki – libreria  
struttura: B42 grafite  
box: C68 rovere moro

Helsinki – bookcase  
frame: B42 grafite  
box: C68 moro oak



setting #04

it — Uno stile eclettico, uno spazio flessibile e anticonformista. Un luogo di lavoro dalla memoria industriale si fa spazio originale, pronto a rispondere alle esigenze della creatività contemporanea. Con arredi che mostrano fieri il loro carattere e le loro qualità, pronti a connotare e valorizzare ogni ambiente in virtù della sua funzione.

en — An eclectic style, a flexible and non-conformist space. An industrial-style workplace becomes an original space, ready to meet the needs of contemporary creativity. With furnishings that proudly show their character and qualities, ready to distinguish and enhance each space according to its function.

de — Ein eklektischer Stil, wandlungsfähige, unkonventionelle Räume. Ein Arbeitsbereich von industrieller Anmutung, der eigenständig wird und bereit, sich den Bedürfnissen einer zeitgemäßen Kreativität anzupassen. Mit Möbeln, die stolz ihren Charakter und ihre Qualität zeigen und jeden Raum nach seiner besonderen Funktion kennzeichnen und zur Geltung bringen.

fr — Un style éclectique, un espace flexible et anticonformiste. Un lieu de travail au passé industriel se transforme en un espace original, prêt à satisfaire les besoins de la créativité contemporaine. Avec des meubles qui affichent fièrement leur caractère et leurs qualités, prêts à renforcer et à mettre en valeur chaque pièce selon sa fonction.

es — Un estilo ecléctico, un espacio flexible y anticonformista. Un lugar de trabajo con memoria industrial se convierte en espacio original, preparado para responder a las necesidades de la creatividad contemporánea. Con mobiliario que muestra orgulloso su carácter y sus cualidades, listo para caracterizar y valorizar cada ambiente según su función.



Quartz — specchio / mirror  
design Arik Levy  
2018

Trace — sedia / chair  
design Shin Azumi  
2005



Fill — sistema / system  
design Studio Ausenda Greco  
2008



Strong — tavolo bistrot  
/ bistrot table  
design Eugeni Quitllet  
2019





desalto collections

Dalla funzionalità  
all'emozione, nello  
stretto dialogo  
tra ambienti e arredi.

From functionality  
to emotion, in a close  
dialogue between  
spaces and furnishings.

**continuity**

setting #05





Lisbona — sedia / chair  
design Pocci + Dondoli  
2009

Element — tavolo / table  
design Tokujin Yoshioka  
2013





Lisbona — sedia  
struttura: nuvola M74 bruno

Lisbona — chair  
frame: nuvola M74 bruno

Element — tavolo  
struttura: D62 court grey

Element — table  
frame: D62 court grey





Armida — sistema  
struttura: B42 grafite

Armida — system  
frame: B42 grafite



Element — tavolino / small table  
design Tokujin Yoshioka  
2013

Armida — sistema / system  
design Caronni + Bonanomi  
1997

struttura: D66 cemento nero  
/ frame: D66 black concrete





Koki — sedia / chair  
design Pocci + Dondoli  
2015

struttura: F39 nero  
/ frame: F39 black

Helsinki 35 office — tavolo / table  
design Caronni + Bonanomi  
1995





Helsinki 35 office – tavolo  
struttura: B13 sabbia  
top: C88 rovere naturale

Helsinki 35 office – table  
frame: B13 sabbia  
top: C88 natural oak



it – Geometrie, tra spazio e luce. Un'ampia e ariosa residenza dal carattere metropolitano genera giochi di connessione tra toni a contrasto e volumi. Arredi e complementi risaltano con decisione, tra essenzialità e minimalismo: elementi dall'aspetto scultoreo, indiscussi protagonisti.

en – Geometries, between space and light. A generous and airy home with a metropolitan feel creates an interplay between volumes and contrasting tones. Furnishings and accessories firmly stand out, between simplicity and minimalism: sculptural elements, undisputed protagonists.

de – Geometrien, aus Raum und Licht. Die großzügige, luftige Wohnung im Charakter einer Metropole erzeugt spielerische Verbindungen von kontrastierenden Farben und Volumen. Möbel und Wohnaccessoires, zwischen essenzieller Funktion und Minimalismus, treten selbstbewusst in den Vordergrund.

fr – Des géométries, suspendues entre l'espace et la lumière. Une demeure spacieuse au caractère métropolitain crée des jeux de connexion entre les couleurs contrastées et les volumes. Les meubles et les accessoires s'affirment avec tempérament, entre essentialité et minimalisme : des éléments d'aspect sculptural, protagonistes incontestés.

es – Geometrías, entre espacio y luz. Una residencia grande y aireada con un carácter metropolitano genera juegos de conexión entre tonos en contraste y volúmenes. Mobiliario y complementos destacan con decisión, entre la esencialidad y el minimalismo, como elementos de aspecto escultórico convertidos en protagonistas indiscutibles.



MM8 — tavolo / table  
design Guglielmo Poletti  
2019



Strong — tavolo / table  
design Eugeni Quitllet  
2019

Mun — sedia / chair  
design Mario Ferrarini  
2019





desalto collections

In sintonia,  
nei diversi spazi  
e momenti del vivere  
quotidiano, insieme.

In harmony,  
in the different spaces  
and moments  
of everyday living,  
together.

**multiplicity**

setting #06



L45 — tavolo / table  
design Guglielmo Poletti  
2020

Koki — sedia / chair  
design Pocci + Dondoli  
2015

Stac — madia / cabinet  
design Giacomo Moor  
2020

L45 — tavolo  
struttura: B62 bianco opaco  
top: D61 cemento bianco

L45 — table  
frame: B62 matt white  
top: D61 white concrete

Koki — sedia  
struttura: F34 grigio chiaro

Koki — chair  
frame: F34 light grey



Stac – madia  
contenitore: C95 noce canaletto  
/ basamento: B42 grafite opaco

Stac – cabinet  
storage unit: C95 canaletto walnut  
/ base: B42 matt grafite



multiplicity



Sail — sistema / system  
Caronni + Bonanomi  
2013

multiplicity





Void — console a parete  
/ wall-mounted console  
design Guglielmo Poletti  
2019

struttura: B59 nero opaco  
/ frame: B59 matt black

Icaro 015 — tavolo / table  
design Caronni + Bonanomi  
2015

Strong — sedia / chair  
design Eugeni Quitllet  
2019





Strong – sedia  
struttura: B42 grafite  
seduta: messenger T96 carbone

Strong – chair  
frame: B42 grafite  
seat: messenger T96 carbone



Icaro O15 – tavolo  
struttura: B42 grafite  
top: D87 ceramica lava

Icaro O15 – table  
frame: B42 grafite  
top: D87 lava ceramic



Fourmore – tavolo / table  
design Gordon Guillaumier  
2020

Ply – sedia / chair  
design Pocci + Dondoli  
2017





Ply – sedia  
struttura: B62 bianco opaco  
rivestimento: cuoio H50 bianco

Ply – chair  
frame: B62 matt white  
covering: cowhide H50 white



Fourmore – tavolo  
struttura: B62 bianco opaco  
top: C88 rovere naturale

Fourmore – table  
frame: B62 matt white  
top: C88 natural oak



Stac — madia / cabinet  
design Giacomo Moor  
2020

L45 — tavolo / table  
design Guglielmo Poletti  
2020

Nara — sedia / chair  
design Piergiorgio Cazzaniga  
2014



multiplicity



L45 – tavolo  
struttura: A21 ossidiana spazzolato  
/ top: C76 rovere grafite

L45 – table  
frame: A21 brushed ossidiana  
/ top: C76 grafite oak

Nara – sedia  
struttura: A18 ossidiana opaco  
rivestimento: messenger T94 ottanio

Nara – chair  
frame: A18 matt ossidiana  
covering: messenger T94 ottanio



Strong – sedia / chair  
design Eugeni Quitllet  
2019

Clay+Lazy Susan – tavolo / table  
design Marc Krusin  
2020



Clay+Lazy Susan — tavolo  
base+top: D66 cemento nero

Clay+Lazy Susan — table  
base+top: D66 black concrete



Strong — sedia  
struttura: A27 titanium  
rivestimento: messenger T95 prussia

Strong — chair  
frame: A27 titanium  
covering: messenger T95 prussia





Kobe — sedia / chair  
design Piergiorgio Cazzaniga  
2011

Skin — tavolo / table  
design Marco Acerbis  
2015





Skin – tavolo  
struttura: A27 titanium  
top: D92 ceramica nero marquina lucido

Skin – table  
frame: A27 titanium  
top: D92 glossy black marquina ceramic

Kobe – sedia  
struttura: B42 grafite  
seduta: F77 grafite

Kobe – chair  
frame: B42 grafite  
seat: F77 grafite



setting #06

it – Ogni ambiente con la sua storia da raccontare. Negli spazi articolati che fondono le quotidianità di vita e lavoro, il confine tra comfort domestico e dimensione professionale si assottiglia con cura, in un'integrazione ponderata che guarda alla funzionalità. Un inno alla poliedricità, guida sensibile.

en – Every room with its very own story to tell. In the varied spaces where everyday life and work merge, the line between home comfort and the professional realm is artfully reduced, in a contemplated combination that looks to functionality. An ode to versatility, our driving spirit.

de – Jeder Raum erzählt seine eigene Geschichte. In gegliederten Bereichen, die Alltagsleben und Arbeit verbinden, wird die Grenze zwischen Wohnkomfort und professioneller Dimension auf kluge Weise schmal, in einer ausgewogenen Integration, die Funktionalität im Fokus hat. Ein Hoch der Vielseitigkeit, einfühlsam geführt.

fr – Chaque pièce a son histoire à raconter. Dans les espaces structurés où se fondent les activités quotidiennes de la vie et du travail, la frontière entre le confort domestique et la dimension professionnelle devient de moins en moins perceptible, dans une intégration minutieuse qui met l'accent sur la fonctionnalité. Un hymne à la polyvalence, un guide sensible.

es – Cada ambiente con su historia por explicar. En los espacios articulados que combinan la cotidianidad de la vida y el trabajo, el límite entre confort doméstico y dimensión profesional se reduce cuidadosamente, con una integración ponderada que busca la funcionalidad. Un himno a la poliédrica, guía sensible.

Calum Office – Task  
design Simon Pengelly  
2022



Calum Office – President  
design Simon Pengelly  
2022





L45 — tavolo / table  
design Guglielmo Poletti  
2020



Stac — madia / cabinet  
design Giacomo Moor  
2020

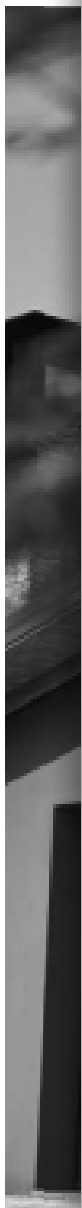



desalto collections

L'armonia  
nel carattere di una  
dimora, ogni giorno  
viva e pronta ad aprirsi.

Harmony  
in the character of  
a home, living  
and ready to open  
up every day.

appeal

setting #07

Ply – sedia / chair  
design Pucci + Dondoli  
2017

struttura: A27 titanium  
seduta: cuoio Q13 avorio

frame: A27 titanium  
seat: cowhide Q13 avorio



L45 – tavolo / table  
design Guglielmo Poletti  
2020

struttura: A27 titanium  
top: L50 poliestere lucido blu reale

frame: A27 titanium  
top: L50 glossy polyester blu reale





Wok — sgabello / stool  
design Pocci + Dondoli  
2005

Wok — sgabello  
struttura: B59 nero  
seduta: pelle M53 nero

Wok — stool  
frame: B59 black  
seat: leather M53 black



Tender — tavolo / table  
design Decoma Design  
1988

Nara — sedia / chair  
design Piergiorgio Cazzaniga  
2014





Nara – sedia  
struttura: A27 titanium  
seduta: messenger T88 tortora

Nara – chair  
frame: A27 titanium  
seat: messenger T88 tortora

Tender – tavolo  
struttura: A27 titanium  
top: E65 cristallo grigio europa

Tender – table  
frame: A27 titanium  
top: E65 grey europa glass

Calum Lounge  
— Comfort+Pouf  
design Simon Pengelly  
2022

Mixit — tavolino  
/ small table  
design Arik Levy  
2005





Helsinki 15 — tavolino  
/ small table  
design Caronni + Bonanomi  
2014

struttura: B59 nero  
top: D87 ceramica lava

frame: B59 black  
top: D87 lava ceramic

Calum Lounge  
— Comfort+Pouf  
struttura: B59 nero  
seduta: nuvola M76 tabacco

Calum Lounge  
— Comfort+Pouf  
frame: B59 black  
seat: nuvola M76 tabacco

Liko Glass — tavolo / table  
design Arik Levy  
2004

Koki Wire — sedia / chair  
design Pocci + Dondoli  
2021



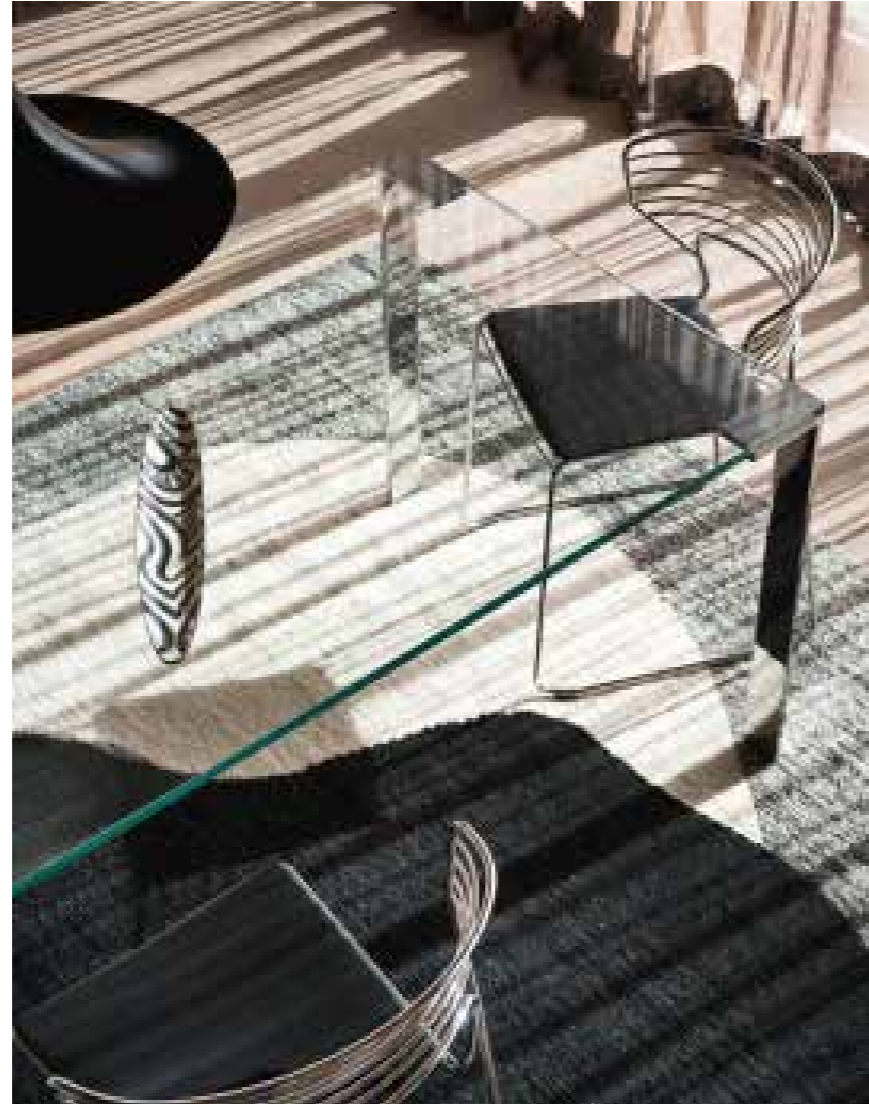

Liko Glass – tavolo  
struttura: A03 cromo  
top: E71 cristallo extrachiaro

Liko Glass – table  
frame: A03 cromo  
top: E71 extrachiaro glass





Koki Wire — sedia  
struttura: A03 cromo  
cuscino: F39 nero

Koki Wire — chair  
frame: A03 cromo  
cushion: F39 black





setting #07

it – L'intimità e l'ospitalità, autentiche e appaganti. Le colline intorno insieme a un grande spazio verde, mentre la luce entra generosa nel casale a mettere in evidenza le sinuosità e le geometrie attentamente ricercate negli interni. La vita si svela e si svolge, in un tempo lento che genera piacevolezza.

en – Intimacy and hospitality, genuine and fulfilling. The surrounding hills, with a green, wide open space, as the light bathes the farmhouse and highlights the carefully designed sinuosities and geometries of the interiors. Life emerges and unfolds, with slow pace that creates wellbeing.

de – Gemütlichkeit und Gastlichkeit, authentisch und befriedigend. Hügellandschaft und grüne Weite rundum, während das Sonnenlicht großzügig in das rustikale Haus einströmt und die fließenden Linien und raffinierten Geometrien der Einrichtung unterstreicht. Das Leben kommt und geht im langsamen Rhythmus und erzeugt ein wohliges Empfinden.

fr – L'intimité et l'hospitalité, authentiques et gratifiantes. Entourée de collines et de grands espaces verts, la lumière pénètre à flots dans la maison de campagne, mettant en valeur les courbes et les géométries soigneusement recherchées dans l'ameublement des pièces. La vie se révèle et s'écoule, à un rythme lent, source de plaisir.

es – La intimidad y la hospitalidad, auténticas y satisfactorias. Las colinas circundantes y un gran espacio verde, mientras la luz entra generosamente en la casa de campo para resaltar la sinuosidad y las geometrías cuidadosamente estudiadas en el interior. La vida se descubre y se desarrolla con un ritmo lento que genera placer.

Liko Glass — tavolo / table  
design Arik Levy  
2004



Hexagon — tavolini / small tables  
design Tokujin Yoshioka  
2013



Koki — sedia / chair  
design Pocci + Dondoli  
2015

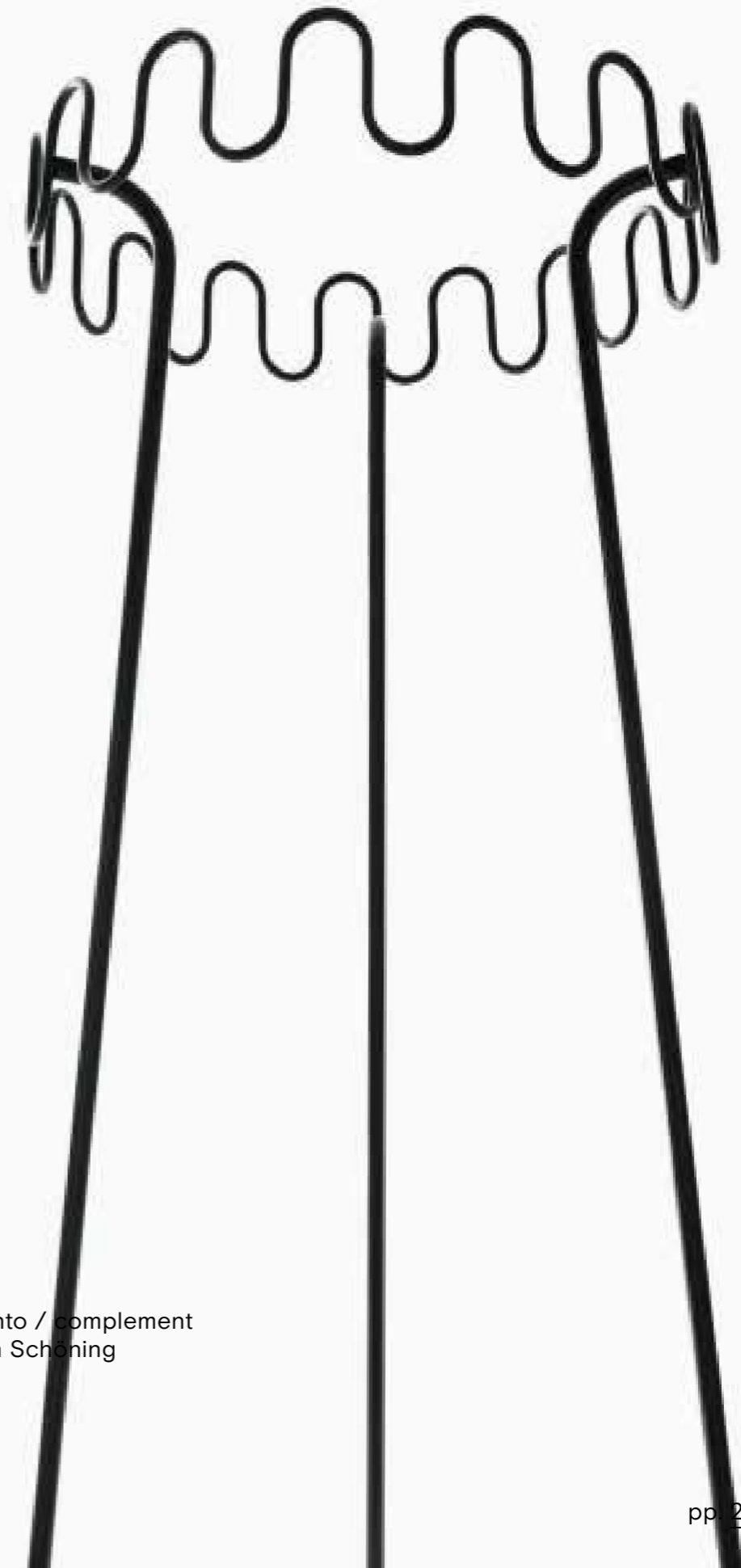

Crown  
— complemento / complement  
design Stefan Schöning  
2002



# consonance

desalto collections

Creare e  
ripensare, esprimere  
e valorizzare.  
In dialogo e in ascolto,  
con attenzione.

Create, rethink,  
express and enhance.  
Speaking and listening,  
with attention.



setting #08



MM8 — tavolo / table  
design Guglielmo Poletti  
2019

struttura+top: B62 bianco opaco  
/ frame+top: B62 matt white

Void — sgabello / stool  
design Guglielmo Poletti  
2019

struttura+top: B62 bianco opaco  
/ frame+top: B62 matt white





struttura: B62 bianco opaco  
/ frame: B62 matt white

Void — console a parete+sgabello  
/ wall console+stool  
design Guglielmo Poletti  
2019



Myg – sgabello / stool  
Mario Ferrarini  
2018

struttura+seduta: F34 grigio chiaro  
/ frame+seat: F34 light grey

Helsinki 30 home – tavolo  
/ table  
Caronni + Bonanomi  
1995

struttura: B62 bianco opaco  
top: D84 bianco calce

frame: B62 matt white  
top: D84 calce white





Beam — tavolo / table  
design Mario Ferrarini  
2018

Sand Light — sedia / chair  
design Pocci + Dondoli  
2010





Beam — tavolo  
top+gambe: C76 rovere grafite  
trave raccordo: B56 ruggine

Beam — table  
top+legs: C76 grafite oak  
connecting beam: B56 ruggine

Sand Light — sedia  
struttura: B59 nero opaco  
rivestimento: S24 canatex nero

Sand Light — chair  
frame: B59 matt black  
covering: S24 black canatex





Ply — sedia  
struttura: B22 marrone bungee  
seduta: cuoietto H55 caffè

Ply — chair  
frame: B22 bungee brown  
seat: cuoietto H55 caffè



Iblea — tavolo  
base: B22 marrone bungee  
top: NO3 calacatta oro

Iblea — table  
base: B22 bungee brown  
top: NO3 calacatta oro





Strong — sgabello+tavolo bistro  
/ stool+bistro table  
design Eugeni Quitllet  
2019

struttura: B62 bianco  
top: B62 bianco

frame: B62 white  
top: B62 white





Lake — tavolo / table  
Gordon Guillaumier  
2018

Mun — sedia / chair  
Mario Ferrarini  
2019

Mun — sedia  
struttura: A18 ossidiana opaco  
rivestimento: messenger T97 acciaio

Mun — chair  
frame: A18 matt ossidiana  
covering: messenger T97 acciaio

Lake — tavolo  
struttura: A18 ossidiana opaco  
top: D92 nero marquina lucido

Lake — table  
frame: A18 matt ossidiana  
top: D92 glossy black marquina



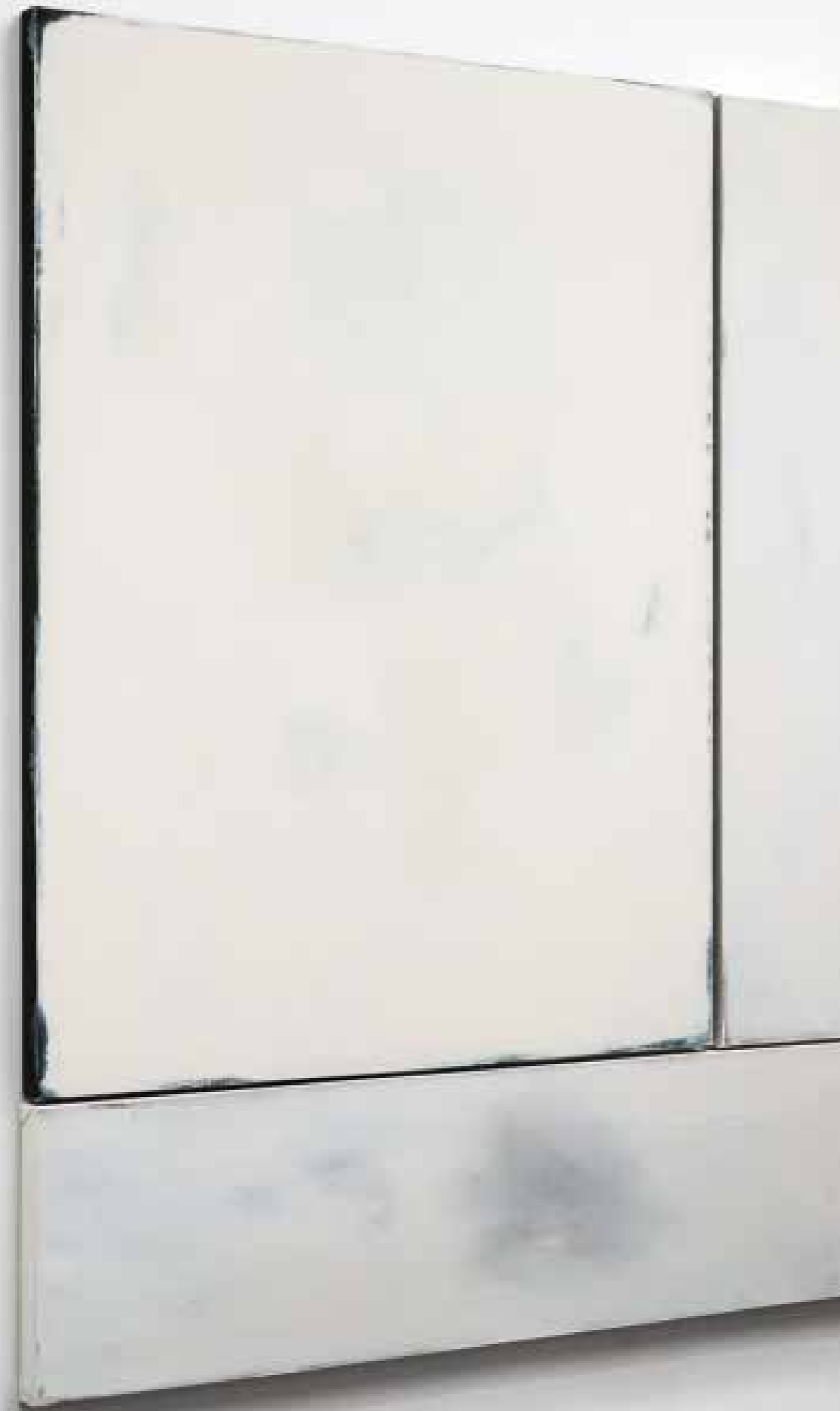

it – Un atelier come un gioco dinamico. Spazi inaspettati si uniscono e accolgono i tempi e le pause del lavoro, in un contenitore composito e flessibile. Per ispirare idee, incoraggiare scambi, favorire relazioni. Esigenze ed efficienze, risolte con stile ed equilibrio in un fine alternarsi di vuoti e pieni.

en – An atelier like a dynamic game. Unexpected spaces are combined and adapt to the rhythms of work, in one composite and flexible container. Inspiring ideas, promoting exchange, nurturing relations. Needs and efficiencies, met with style and balance in a subtle alternation of voids and volumes.

de – Ein Atelier in dynamischer Gestaltung. Überraschende Räume vereinigen sich und nehmen Arbeitszeiten und Pausen auf, in einer zusammengesetzten, flexiblen Einheit. Ideen anregen, Gedankenaustausch ermutigen, Beziehungen fördern. Bedürfnisse und Effizienz, stilvoll und harmonisch gelöst in einem eleganten Wechsel der vollen und offenen Volumen.

fr – Un atelier comme un jeu dynamique. Des espaces inattendus s'unissent et accueillent les moments de travail et les pauses, dans un espace composite et flexible. Pour susciter les idées, encourager les échanges, favoriser les relations. Besoins et efficacité, résolus avec style et équilibre dans une alternance subtile de vides et de pleins.

es – Un taller como juego dinámico. Espacios inesperados confluyen y acogen momentos de trabajo y pausas, en un recipiente compuesto y flexible. Para inspirar ideas, fomentar intercambios y propiciar relaciones. Necesidades y eficiencias, solucionadas con estilo y equilibrio en una alternancia delicada de llenos y vacíos.



Endless — sgabello / stool  
design Arik Levy  
2017



Koki Wire — sedia / chair  
design Pocci + Dondoli  
2021





Strong Special — lounge  
design Eugeni Quitllet  
2022

Sail — sistema / system  
design  
Caronni + Bonanomi  
2013





desalto collections

Cogliere  
l'anima di un luogo,  
nell'esperienza  
dell'abitare.

Capturing  
the spirit of a place,  
in the experience  
of living.

in between

setting #09





Strong Special – lounge  
+divanetto+tavolino  
/ lounge+sofa+small table  
design Eugeni Quitllet  
2022

Strong Special – tavolino  
struttura: B13 sabbia  
top: D61 cemento bianco

Strong Special – small table  
frame: B13 sabbia  
top: D61 white concrete



Strong Special – lounge  
+divanetto

struttura: B13 sabbia  
seduta: terry H57 lana

Strong Special – lounge  
+sofa

frame: B13 sabbia  
seat: terry H57 lana



Helsinki 35 extending / table  
design Caronni + Bonahomi  
2022

Calum Home — 4 Stars  
design Simon Pengelly  
2022





in between



Helsinki 35 extending – tavolo  
struttura: B62 bianco opaco  
top: D94 industrial white

Helsinki 35 extending – table  
frame: B62 matt white  
top: D94 industrial white

Calum Home – 4 Stars  
struttura: B59 nero opaco  
seduta: highlands l62 pepe

Calum Home – 4 Stars  
frame: B59 matt black  
seat: highlands l62 pepe





Calum Home – Wood  
design Simon Pengelly  
2022

Ellis – tavolo / table  
design Pocci + Dondoli  
2021





Calum Home — Wood  
struttura: C88 rovere naturale  
seduta: network H89 neve

Calum Home — Wood  
frame: C88 natural oak  
seat: network H89 neve



Ellis — tavolo  
struttura: B62 bianco  
top: D58 cemento ghiaccio

Ellis — table  
frame: B62 white  
top: D58 ghiaccio concrete



Calum Home — Cantilever  
design Simon Pengelly  
2022

MM8 — tavolo / table  
design Guglielmo Poletti  
2019





Calum Home – Cantilever  
struttura: B42 grafite  
seduta: highlands I57 muschio

Calum Home – Cantilever  
frame: B42 grafite  
seat: highlands I57 muschio

MM8 – tavolo  
struttura: B42 grafite opaco  
top: B42 grafite

MM8 – table  
frame: B42 matt grafite  
top: B42 grafite



Clay – tavolo / table  
design Marc Krusin  
2015

struttura: D61 cemento bianco  
/ frame: D61 white concrete





Koki Wire cuoio — sedia  
struttura: A03 cromo  
seduta: cuoio Q06 bianco

Koki Wire cuoio — chair  
frame: A03 cromo  
seat: cowhide Q06 white

in between

Koki Wire cuoio — sedia / chair  
design Poggi + Dondoli  
2022





Calum Home — Sled  
design Simon Pengelly  
2022

Clay — tavolo / table  
design Marc Krusin  
2015

in between







Calum Home – Sled  
struttura: A18 ossidiana  
seduta: highlands I51 peonia

Calum Home – Sled  
frame: A18 ossidiana  
seat: highlands I51 peonia



Clay – tavolo  
struttura: D59 cemento cacao  
top: D59 cemento cacao

Clay – table  
frame: D59 cacao concrete  
top: D59 cacao concrete





it – Il paesaggio, naturale e domestico, come elemento ordinatore. Spazi che sono insieme un mondo, tra casa e atelier, in successione. Gli arredi vivono nel riflesso della luce e il loro linguaggio entra in dialogo con la struttura. Un panorama per vivere tra interno ed esterno, grazie a dettagli, visuali e aperture.

en – The landscape, natural and domestic, as a guiding element. Spaces that together create a world, between the home and the office, in succession. The furnishings come alive in the reflection of the light, and their language converses with the structure. A panorama for living in between indoors and outdoors, thanks to details, visuals and openings.

de – Eine Landschaft, natürlich und häuslich, ist ordnendes Element. Räume, die eine ganze Welt ausmachen: Wohnung und Atelier, die aufeinanderfolgen. Lichtreflexe machen die Einrichtung lebendig, die einen Dialog mit den Strukturen eingeht. Ein Panorama, um Innen- und Außenbereiche zu leben, dank visueller Details und Öffnungen nach außen.

fr – Le paysage, naturel et domestique, comme élément ordonnateur. Des espaces qui constituent ensemble un environnement fluide entre maison et atelier, en succession. Les meubles vivent dans le reflet de la lumière et leur langage entre en dialogue avec la structure. Un panorama pour vivre entre l'intérieur et l'extérieur, grâce à des détails, des vues et des ouvertures.

es – El paisaje, natural y doméstico, como elemento coordinador. Espacios que juntos se convierten en un mundo, entre hogar y taller, en sucesión. El mobiliario vive en el reflejo de la luz y su lenguaje dialoga con la estructura. Un panorama para vivir entre el interior y el exterior gracias a detalles, vistas y aperturas.

Riga — sedia / chair  
design Pocci + Dondoli  
2008



Flan — sgabello / stool  
design Pocci + Dondoli  
2008



288 — sedia / chair  
design Pocci + Dondoli  
2009

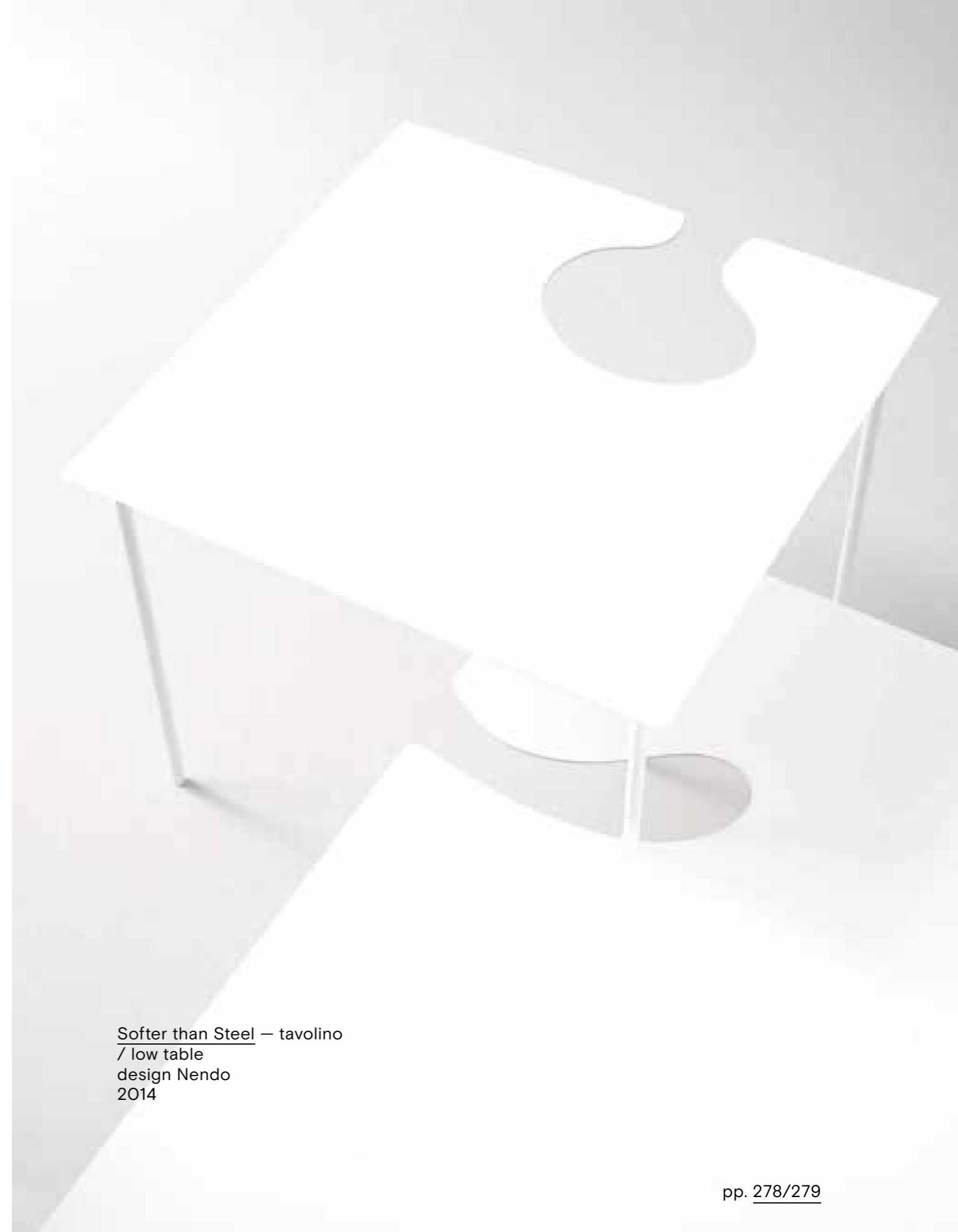

Softer than Steel — tavolino  
/ low table  
design Nendo  
2014

abaco



systems

Armida	p. 283
Fill	p. 284
Hang	p. 285
Helsinki	p. 286
Mini Booxx	p. 287
Sail	p. 288
Stac	p. 290
Step	p. 291

tables

25	p. 292
Beam	p. 293
Clay	p. 294
Clay+Lazy Susan	p. 295
Element	p. 296
Ellis	p. 298
Every	p. 299
Fan	p. 300
Fourmore	p. 301
Helsinki 30 – home	p. 302
Helsinki 30 – home extending	p. 303
Helsinki 35 – home	p. 304
Helsinki 35 – home extending	p. 305
Helsinki 35 – office	p. 306
Helsinki 35 – outdoor	p. 307
Iblea	p. 308
Icaro 015	p. 309
Kobe	p. 310
L45	p. 311
Lake	p. 312
Liko Glass	p. 313
Link	p. 314
Mac	p. 316
MM8	p. 317
Skin	p. 318
Strong – table	p. 319
Strong – bar table	p. 320
Tender	p. 321

seating

288	p. 322
Aria	p. 323
Calum Office	p. 324
Calum Home	p. 326
Calum Lounge	p. 327
Endless	p. 328

Flan	p. 329
Kobe	p. 330
Koki	p. 331
Koki Wire	p. 332
Koki Wire – cuoio	p. 333
Lisbona	p. 334
Mun	p. 335
Myg	p. 336
Nara	p. 337
Paper	p. 338
Ply	p. 339
Riga	p. 340
Sand	p. 341
Sand Air	p. 342
Sand Light	p. 343
Softer than Steel – chair	p. 344
Softer than Steel – bench	p. 345
Strong Special	p. 346
Strong – chair	p. 347
Strong – stool	p. 348
Trace	p. 349
Void	p. 350
Wok	p. 351

small tables + console

Element	p. 352
Helsinki 15	p. 353
Helsinki 30	p. 354
Hexagon	p. 355
Icaro 015	p. 356
L45	p. 357
Liko Glass	p. 358
Mini Clay	p. 359
Mixit + Mixit Glass	p. 360
Softer than Steel	p. 361
Void	p. 362

complements

Crown – coat stand	p. 363
Dadi	p. 364
Helsinki – trolley	p. 365
Mir – mirror	p. 366
Quartz – mirror	p. 367
Softer than Steel – coat stand	p. 368
Unus	p. 369

## Armida

design Caronni + Bonanomi  
1997

Sistema modulare di librerie con piantane in trafilato di acciaio disponibili in due versioni: piantana a parete e piantana con fissaggio pavimento/soffitto. Ripiani in lamiera o in cristallo. Contenitori con struttura e anta a ribalta in MDF laccato.

Modular bookcase system with drawn-steel uprights available in two versions: upright with wall fixing and floor/ceiling upright. Shelves in metal plate or glass. Storage unit with frame and drop-leaf door in lacquered MDF.

Regalsystem mit Ständern aus gezogenem Stahl, verfügbar in zwei Versionen: Ständer für Wandmontage und Ständer für Deckenmontage. Regalböden aus Metall oder aus Glas. Container mit Gestell und Klapptür aus lackiertem MDF.

Système modulaire de bibliothèques avec montants en acier tréfilé disponibles en deux versions: montant à fixation murale et montant sol-plafond. Étagères en métal ou en verre. Éléments de rangement avec structure et porte rabattable en MDF laqué.

Sistema modular de librerías con montantes en acero trefilado disponible en dos versiones: montante a pared y montante a techo. Estantes en chapa o en cristal. Contenedores con estructura y porta abatible en MDF lacado.

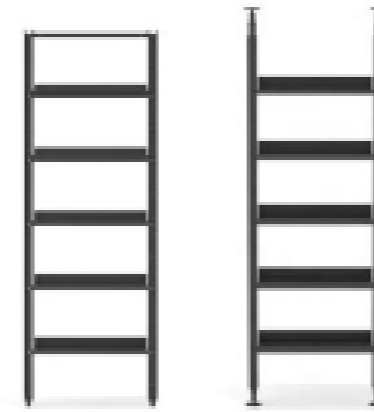

Armida

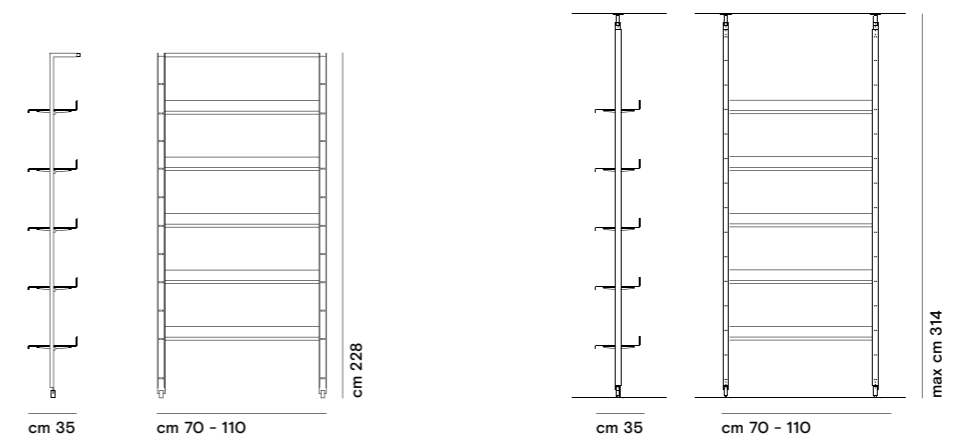

## Fill

design Ausenda Greco  
2008

Sistema di librerie composto da spalle verticali e ripiani in alluminio estruso. Gli schienali, in lamiera di acciaio, sono liberamente applicabili sul retro della libreria. Le spalle sono dotate di piedini regolabili. Ante in cristallo acidato retroverniciato disponibili solo per modulo L 80 cm H 36 cm.

Bücherregalsystem mit senkrechten Seiten und Böden aus extrudiertem Aluminium. Die Rückwände aus Edelstahlblech werden einfach an dem Bücherregalrücken positioniert. Die Seiten haben verstellbare Füße. Türen aus geätzttem, hinterlackiertem Glas, verfügbar für Modul B 80 cm H 36 cm.

Sistema de librerías compuesto de laterales verticales y estantes en aluminio estruso. Las traseras en chapa de acero, son libremente aplicables sobre la parte trasera de la librería. Los laterales están dotados de pies regulables. Puertas en cristal acidado pintado por detrás, disponible solo para el módulo A 80 cm H 36 cm.

Bookcase system composed of upright side panels and extruded aluminium shelves. The back panels, in metal sheet, can be freely assembled on the back of the bookcase. The side panels are provided with adjustable feet. Back-lacquered opaque glass doors, available only for the element W 80 cm H 36 cm.

Système de bibliothèques composé par des côtés verticaux et des étagères en aluminium extrudé. Les dossiers en acier peuvent être fixés sur l'arrière de la bibliothèque. Les côtés sont équipés de pieds réglables. Portes en verre dépoli, rétrolaquées disponibles seulement pour le module L 80 cm H 36 cm.



Fill

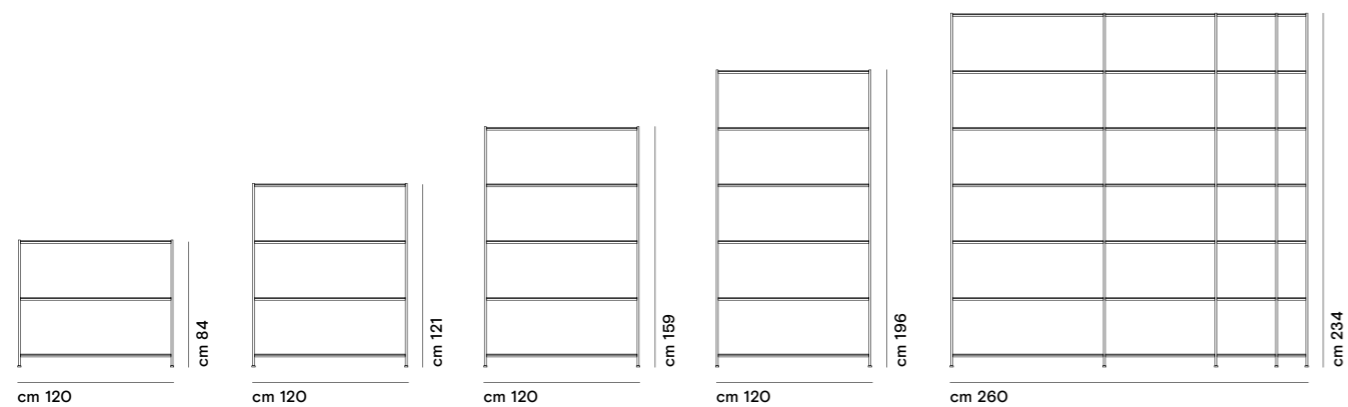

## Hang

design Claudio Caramel  
2008

Sistema di mensole in alluminio estruso. Le mensole sono dotate di un sistema di regolazione per ottenere una corretta angolazione di 90° con la parete. Unendo più moduli si ottengono mensole senza limiti di lunghezza.

Regalsystem aus Fließpreßaluminium. Ein Regulationssystem erlaubt es, den richtigen 90° Winkel mit der Wand zu erhalten. Durch eine Verbindung von mehreren Elementen kann man Böden mit unbegrenzten Länge zusammensetzen.

Sistema de baldas en aluminio estruso. Las baldas están dotadas de un sistema de regulación para obtener una correcta angulación de 90° sobre la pared. Uniendo varios módulos se obtienen baldas tan largas como se desee.

Shelving system of extruded aluminium. A regulation mechanism allows to obtain an exact 90° angle to the wall. Different configurations can be obtained without limits of length, by joining more pieces together.

Système d'étagères en aluminium extrudé. Étagères équipées d'un système de réglage pour réaliser un angle parfait de 90° avec le mur. Avec plusieurs modules on peut obtenir des étagères sans limite de longueur.



Hang



dettaglio / detail

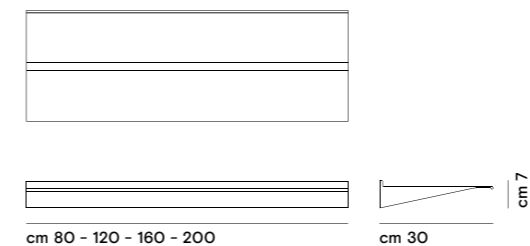



## Helsinki

design Caronni + Bonanomi  
2009

Sistema di librerie con struttura in tubi di acciaio, giunti in pressofusione di alluminio e mensole in lamiera scatolata. Ogni modulo è dotato di piedino in acciaio regolabile. Contenitori (con apertura a ribalta) in MDF.

Bücherregalsystem mit Gestell aus Stahlrohren, Verbindungselementen aus Druckgussaluminium und Böden aus gebogenem Metall. Die Einzelmodule sind verfügbar mit höhenverstellbarem Fuß aus Stahl. Container mit Flügeltür aus MDF.

Sistema de libreria con estructura en tubos de acero, juntas en presofusión de aluminio y estantes en chapa curvada. Cada módulo de forma independiente van dotados de patitas regulables en acero. Contenedor con puerta abatible en MDF.

Bookcase system with steel tubular structure, die-cast aluminium joints and folded shelves of metal sheet. The modules are available with steel adjustable feet. MDF storage units with drop-leaf door.

Système de bibliothèques avec structure tubulaire en acier, joints en aluminium moulés sous pression et étagères en métal plié. Les modules sont disponibles avec patins d'acier réglables. Éléments de rangement avec ouverture rabattable en MDF.

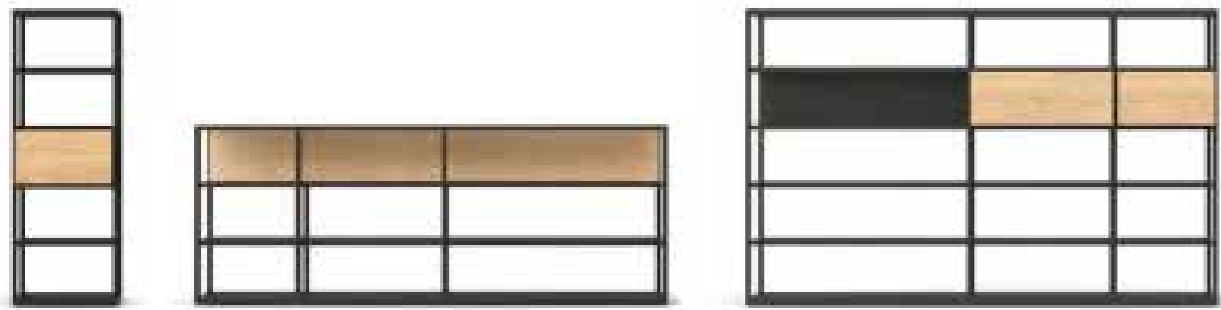

Helsinki

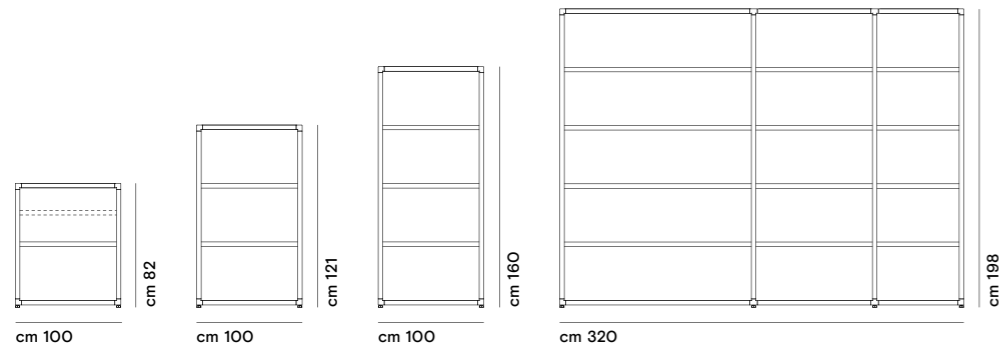

larghezza ripiani / shelves width: cm 70 - 100 - 150  
profondità / depth: cm 36

## Mini Boox

design Denis Santachiara  
2006

Libreria con struttura in piatto di acciaio e 5 fermalibri asportabili in lamiera. La struttura a pantografo permette un libero posizionamento della libreria sulla parete, in base a necessità estetiche o di spazio.

Bücherregal aus Flachstahl und Böden in Metallblech mit 5 entfernbarer Buchstützen aus Metall. Das "Pantograph" Gestell erlaubt eine flexible Positionierung an der Wand, das ganz nach Geschmack und Platzbedarf ausgezogen werden kann.

Librería con estructura en plancha de acero y estantes en laminado de acero con 5 sujetalibros móviles en chapa. La estructura a pantógrafo permite un libre posicionamiento de la librería en la pared, en base a la necesidad estética o de espacio.

Bookshelf with steel plate frame and shelves with 5 removable bookends of metal sheet. The pantograph frame allows a free bookcase position on the wall, to satisfy aesthetics or space requirements.

Bibliothèque en acier avec étagères en métal et un jeu de 5 bloques-livres positionnables en métal. La structure en forme de pantographe permet le libre positionnement au mur, en répondant aux nécessités esthétiques ainsi que de place.



Mini Boox

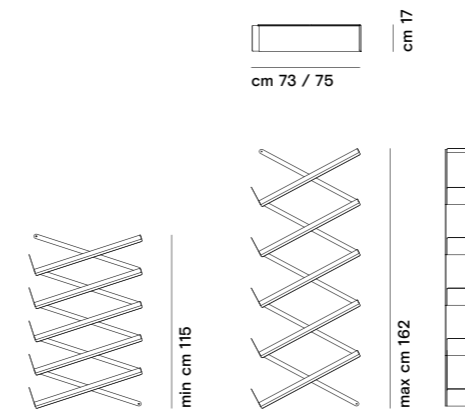

Porta TV per schermi ultrapiatti e curvi. Struttura girevole in acciaio, dotata di vano alloggiamento cavi. Disponibile in quattro varianti: con base dotata di rotelle monodirezionali, con base dotata di canalina passacavi posteriore, con sistema di fissaggio posteriore a parete, e con piantana pavimento /soffitto.

TV-Träger für Flachbildschirme und gebogene Bildschirme. Drehbares Stahlgestell ausgerüstet mit Kabelkanal. Verfügbar in vier Versionen: mit eingebauten Rollen, mit Kabelkanal hinten, mit hinterer Befestigung an der Wand und mit drehbarem Ständer für Deckenmontage.

Porta TV específica para pantallas ultraplanas y curvas. Estructura giratoria en acero, dotada de canal pasacables. Disponible en cuatro versiones: con base dotada de ruedas unidireccionales, con base dotada de canal pasacables posterior, con fijación posterior a la pared y con estructura pivotante a techo.

Tv-stand system for flat and curved screens. Swivelling steel frame. Integrated wiring box. Available in four versions: with base equipped of built-in monodirectional castors, with rear cable management, with rear wall-fixing system and with swivelling floor-ceiling upright.

Porte TV spécifique pour écrans ultraplats et courbé. Structure pivotante en acier, équipée de réceptacle de câblage. Disponible dans quatre versions: avec base à roulettes unidirectionnelles, équipée d'une rainure arrière pour le passage des câbles, avec fixation arrière au mur et avec montant pivotant sol-plafond.



Sail

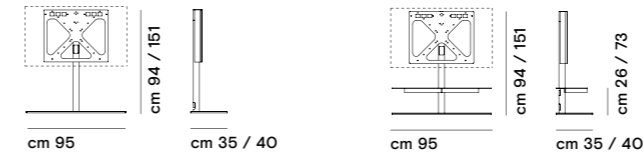

Sail

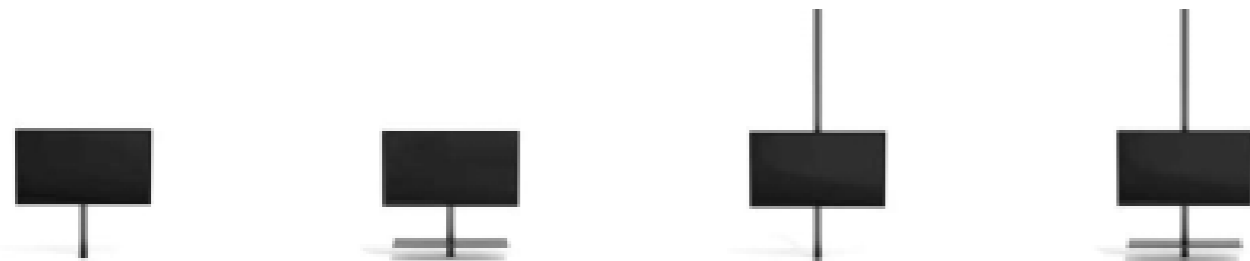
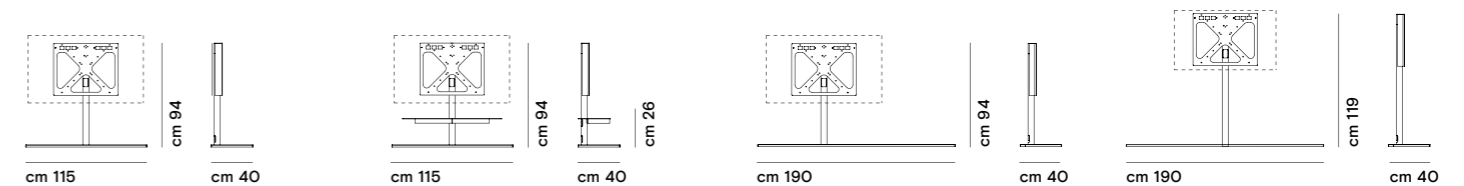

Sail

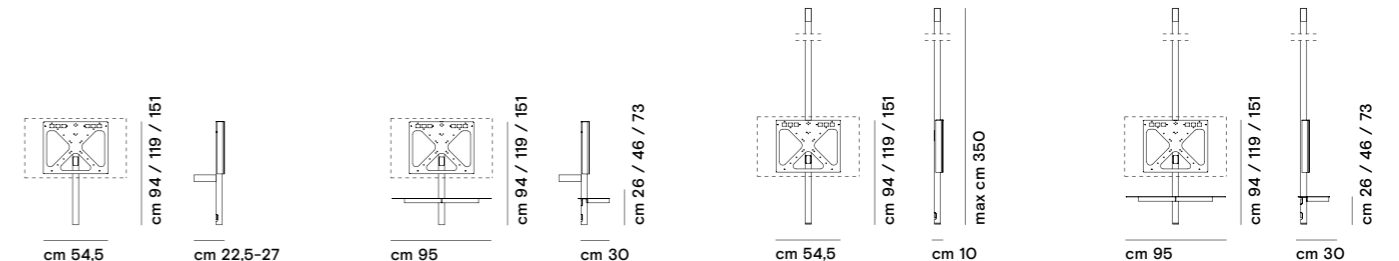

## Stac

design Giacomo Moor  
2020

Sistema di contenitori in legno con struttura in lamiera di metallo.

System von Holzcontainern mit Basis aus Stahlblech.

Sistema de contenedores en madera con base en acero.

Wooden containers system with metal sheet structure.

Système d'éléments de rangement en bois avec base en acier.



Stac

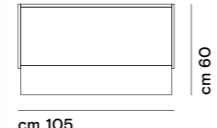

cm 105

cm 60

profondità / depth: cm 45

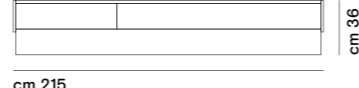

cm 215

cm 36

profondità / depth: cm 45



Stac

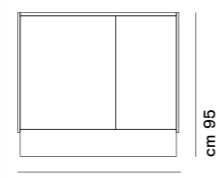

cm 105

cm 95

profondità / depth: cm 45

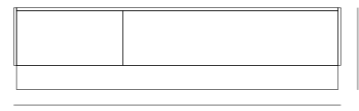

cm 215

cm 54

profondità / depth: cm 45



Stac

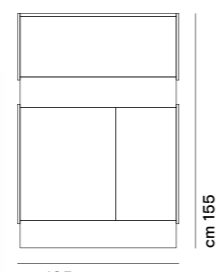

cm 105

cm 155

profondità / depth: cm 45

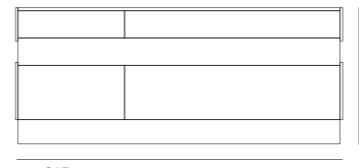

cm 215

cm 90

profondità / depth: cm 45

## Step

design Nendo  
2019

Libreria in MDF bilaminato, spessore 12 mm, laccata opaco.

Bücherregal mit laminierten MDF Böden, Stärke 12 mm, matt lackiert.

Librería de MDF bilaminado, espesor 12 mm, lacada mate.

Bookcase in bilaminated MDF, 12 mm thickness, matt lacquered.

Bibliothèque en MDF avec deux côtés laminés, épaisseur 12 mm, laquée mate.



Step



cm 50

cm 32

cm 210



Step

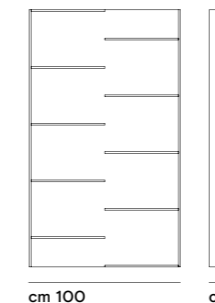

cm 100

cm 32

cm 170

Tavolo con piano spessore 25 mm in materiale composito rivestito in resina acrilica, essenza di rovere o nelle finiture spatolate. Gambe sezione 25x25 mm in acciaio laccato, ossidiana oppure rivestite interamente nelle finiture spatolate.

Tisch mit Platte aus Verbundwerkstoff, 25 mm Stärke, bezogen aus Acrylharz, furniertem Holz oder in den handgespachtelten. Beine mm 25x25 aus lackiertem Stahl, Ossidiana-Ausführung, oder in gespachtelten Ausführungen.

Mesa con encimera de espesor 25 mm hecha de material compuesto recubierto de resina acrilica, madera de roble o en los acabados aplicados con espátula. Patas en sección 25x25 mm, de acero en los acabados lacado, ossidiana o totalmente revestidas de los acabados aplicados con espátula.

Table with 25 mm thickness top made of a composite material covered with acrylic resin, oak wood veneered, or covered with hand-spread pastes. Legs with 25x25 mm section in lacquered steel, ossidiana or entirely covered with hand-spread pastes.

Table avec plateau d'épaisseur 25 mm en matériau composite revêtu en résine, en chêne ou dans les finitions étalées avec une spatule. Pieds section 25x25 mm en acier laqué, ossidiana ou entièrement revêtus des finitions étalées à main avec une spatule.

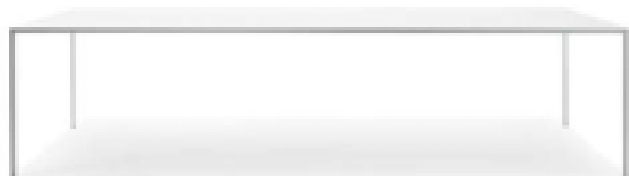

25

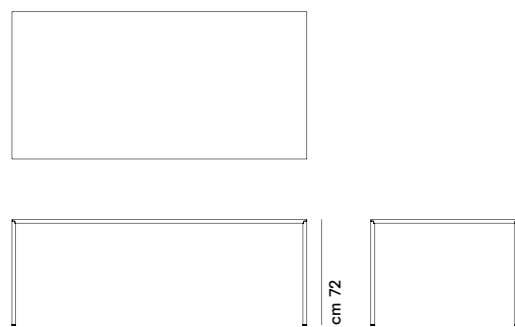

cm 80x170  
cm 90x180  
cm 90x200  
cm 90x240  
cm 100x200  
cm 100x240  
cm 100x300  
cm 110x240  
cm 110x300  
cm 149x149



detail

Tavolo fisso o allungabile (con 1 o 2 allunghe da 45 cm), struttura in acciaio e alluminio. Piano e prolunghe in MDF leggero, spessore 25 mm. Disponibile in una vasta gamma di finiture: legno e Fenix® laminato. Gambe in alluminio estruso laccate o rivestite in essenza, nello stesso colore del top. Trave di raccordo tra le gambe in acciaio, disponibile in varie finiture.

Fester oder ausziehbarer Tisch (mit 1 oder 2 Ausziehplatten 45 cm), Gestell aus Stahl und Aluminium. Platte und Ausziehplatten aus leichtem MDF, Stärke 25 mm. Verfügbar in vielen Ausführungen: Holz und Fenix® Laminat. Beine aus extrudiertem Aluminium, lackiert oder holzurniert, in der gleichen Farbe der Platte. Verbindungstraverse zwischen der Beine aus Stahl, verfügbar in verschiedenen Ausführungen.

Mesa fija o extensible (con 1 o 2 extensiones de 45 cm), estructura en acero y aluminio. Encimera y extensiones en MDF ligero, espesor 25 mm. Disponible en una amplia gama de acabados: madera o Fenix® laminado. Patas en aluminio extruido lacadas o recubiertas de madera, en el mismo color que la encimera. Barra de conexión entre las patas en acero, disponible en varios acabados.

Fixed or extending table (with 1 or 2 leaves, cm 45 deep), steel and aluminium frame. Top and leaves in light MDF, 25 mm thickness. Available in many finishes: wood and Fenix® laminate. Extruded aluminium legs, lacquered or wood veneered in the same colour as the top. Connecting beam between the legs in steel, available in many finishes.

Table fixe ou à rallonges (avec 1 ou 2 rallonges de 45 cm), structure en acier et aluminium. Plateau et rallonges en MDF léger, épaisseur 25 mm. Disponible en plusieurs finitions: bois ou Fenix® laminé. Pieds en aluminium extrudé, laqués ou plaqués en bois, dans la même couleur que le plateau. Barre de connexion entre les pieds en acier, disponible en plusieurs finitions.

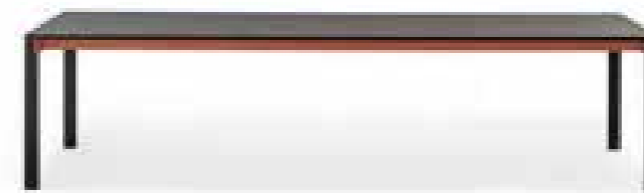

Beam

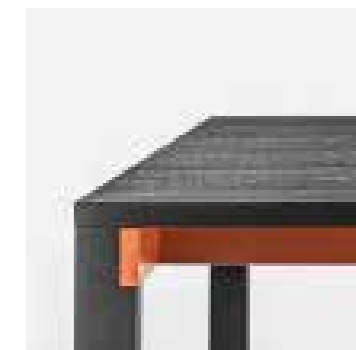

dettaglio / detail



cm 90x140  
cm 90x180  
cm 90x200  
cm 100x240  
cm 100x300

fisso / fixed



cm 90x140 (185/230)  
cm 90x180 (225/270)  
cm 90x200 (245/290)

allungabile / extending

## Clay

design Marc Krusin  
2015

Tavolo con base in poliuretano rigido realizzato nelle finiture laccate o materiche spatolate a mano. Basi e piani tondi oppure ellittici. Top in cristallo, ceramica, MDF rivestito o marmo. Disponibile nelle versioni indoor e outdoor.

Tisch mit Basis aus hartem Polyurethan mit lackierter oder handgespachtelter Oberfläche. Runde oder elliptische Basis und Tischplatten. Tischplatten aus Glas, Keramik, handgespachteltem MDF oder Marmor. Verfügbar in der Ausführung für In- und Outdoor.

Mesa con base de poliuretano rígido en acabado lacado o texturizado con pasadas de espátula a mano. Bases y encimeras redondas o ovaladas. Encimera de cristal, cerámica, MDF tapizado o mármol. Disponible en las versiones para interiores y exteriores.

Table with base in rigid polyurethane available in lacquered finishing or covered with hand-spread materic finishes. Round or elliptical bases and tops. Tops in glass, ceramic, covered MDF or marble. Available in indoor and outdoor versions.

Table avec base en polyuréthane rigide disponible dans les finitions laquées ou « texture » obtenues par application manuelle. Bases et plateaux ronds ou elliptiques. Plateaux en verre, céramique, MDF revêtu, ou en marbre. Disponible dans les versions pour intérieur et extérieur.



Clay

dettaglio / detail

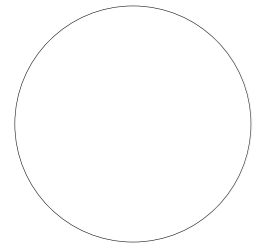

cm Ø 120  
cm Ø 140  
cm Ø 160  
cm Ø 180  
cm Ø 200

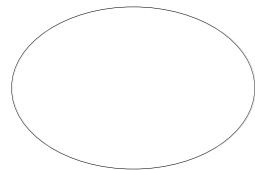

cm 160×110  
cm 180×120  
cm 200×120  
cm 218×120

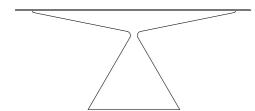

cm 73 / 74,4

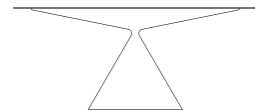

cm 73 / 74,4

## Clay+Lazy Susan

design Marc Krusin  
2020

Tavolo con vassoio girevole incorporato o d'appoggio dotato di meccanismo di rotazione su cuscinetti a sfera. Basamento in poliuretano rigido e piano in MDF. Vassoio girevole nella stessa finitura del tavolo.

Tisch mit integriertem drehbarem Tablett oder überlappendem Lazy Susan mit Rotationsmechanismus auf Kugellager. Basis aus hartem Polyurethan und MDF Platte. Derhbares Lazy Susan in der gleichen Ausführung des Tisches.

Mesa con bandeja central giratoria incorporada en rasado al top o superpuesta equipada con mecanismo de rotación sobre rodamientos con bolas. Base en poliuretano rígido y encimera en MDF. Bandeja giratoria en el mismo acabado que la mesa.

Table with built-in rotating tray or overlapping Lazy Susan with rotating mechanism on ball bearings. Base in rigid polyurethane and MDF top. Rotating tray in the same finish as the table.

Table avec plateau central pivotant intégré en affleurement ou superposé équipé d'un mécanisme de rotation sur roulement à billes. Base en polyuréthane rigide et plateau en MDF. Plateau pivotant dans la même finition que la table.



Clay+Lazy Susan  
vassoio girevole incorporato  
/ built-in rotating tray

Clay+Lazy Susan  
vassoio girevole d'appoggio  
/ rotating tray

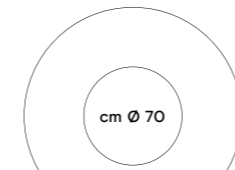

cm Ø 70

cm Ø 160

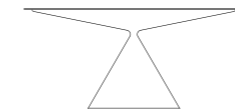

cm 74,4

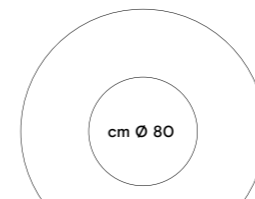

cm Ø 80

cm Ø 180

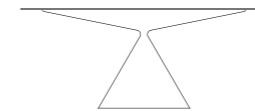

cm 74,4

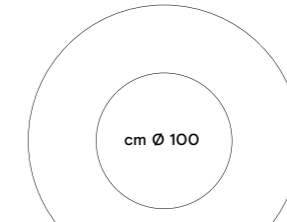

cm Ø 100

cm Ø 200

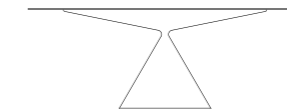

cm 74,4



Tavolo con struttura in acciaio,  
piani in metallo o MDF, nelle finiture  
laccate o materiche spatolate a  
mano.

Tisch mit Stahlgestell, Tischplatte  
aus Metall oder MDF, mit lackierten  
oder Hand-gepatelten  
Oberflächen.

Mesa con estructura de acero,  
encimeras en metal o MDF,  
en acabado lacado o matérico  
espatulado a mano.

Table with steel frame, metal or  
MDF top, lacquered or covered with  
hand-spread materic finishes.

Table avec structure en acier,  
plateaux en métal ou MDF, dans  
les finitions laquées ou matériaux  
spatulés à la main.

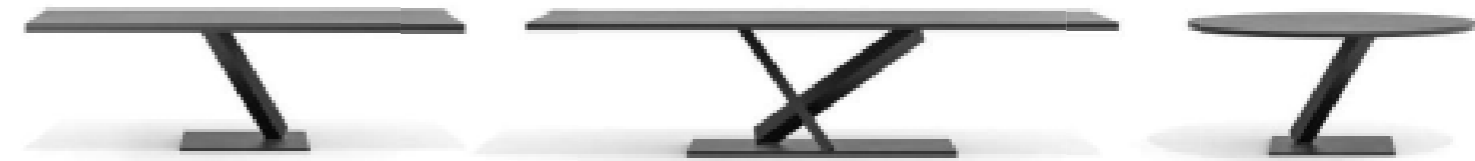

Element

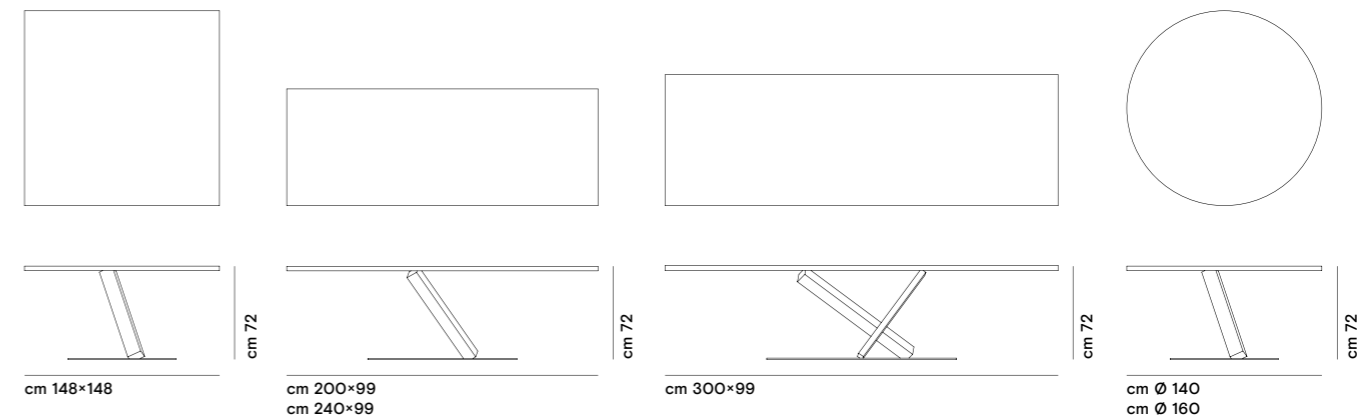

## Ellis

design Pocchi + Dondoli  
2021

Famiglia di tavoli outdoor e indoor con base in ghisa e tubo di acciaio, top in ceramica.

Familie von Tischen für In- und Outdoor mit Gusseisengestell und Stahlrohr, Keramikplatte.

Familia de mesas de exterior y interior con base de hierro fundido y tubo de acero, encimera de cerámica.

Family of outdoor and indoor tables with cast iron base and steel tube, ceramic top.

Famille de tables pour extérieur et intérieur avec base en fonte et tube en acier, plateau en céramique.

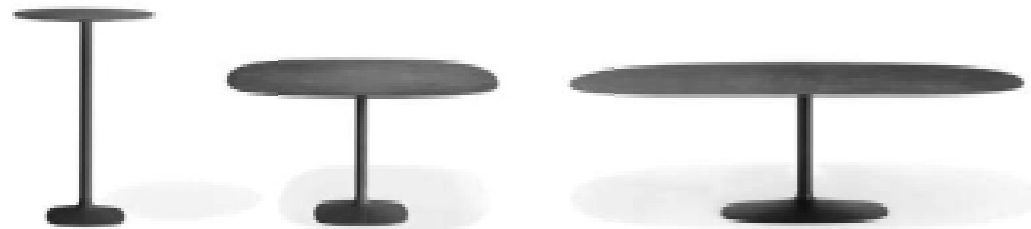

Ellis

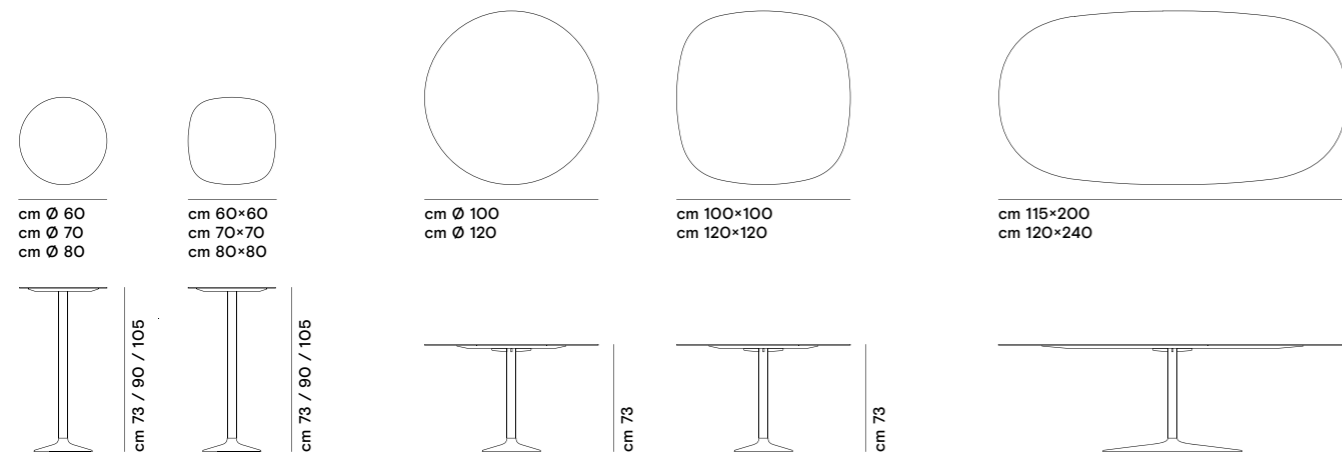

## Every

design Caronni + Bonanomi  
2009

Tavolo allungabile con struttura e guide in estruso di alluminio. Piani disponibili in cristallo o in Alucompact®. Piani di prolunga in Alucompact®. Due maniglie estraibili permettono di allungare agevolmente la struttura. Disponibile nelle versioni indoor e outdoor.

Ausziehtisch mit Gestell und Stangen aus extrudiertem Aluminium. Tischplatte verfügbar aus Glas oder Alucompact®. Ausziehplatte aus Alucompact®. Zwei Ausziehgriffe erlauben eine mühelose Betätigung der Funktion. Verfügbar für In- und Outdoor.

Mesa extensible con estructura y guías en estruso de aluminio. Sobres disponibles en cristal o en Alucompact®. Sobres extensibles en Alucompact®. Dos tiradores extraíbles permiten la extensión fácil de la estructura. Disponible en las versiones de interior y de exterior.

Extending table with extruded aluminium structure and guides. Glass or Alucompact® tops available. Extensions in Alucompact®. Two extractable handles allow to easily extend the frame. Available in indoor and outdoor versions.

Table à rallonges avec structure et guides en aluminium extrudés. Plateaux disponibles en verre ou en Alucompact®. Rallonges en Alucompact®. Deux poignées extractibles permettent d'allonger facilement la structure. Disponible dans les versions pour intérieur et extérieur.



Every

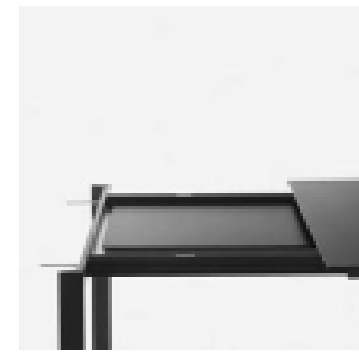

dettaglio / detail

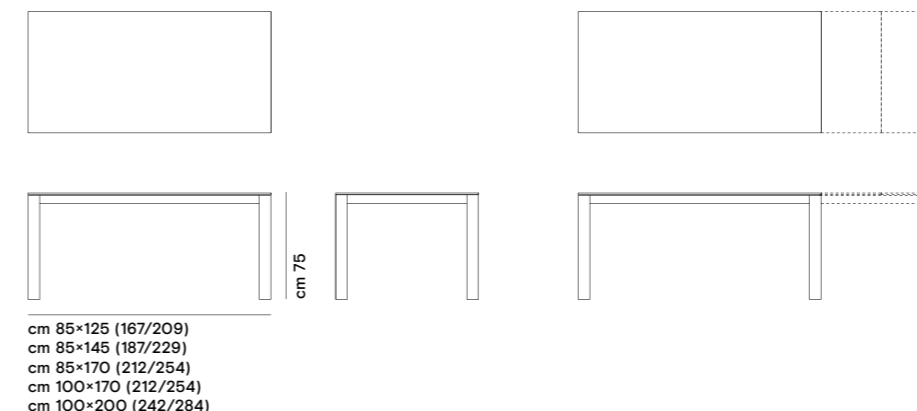

allungabile / extending

## Fan

design Piero Lissoni  
2014

Tavolo con gambe in lamiera di acciaio in finitura ferro grezzo o laccate. Piano realizzato in massello di rovere naturale "effetto segato" oppure nelle finiture materiche spatolate.

Tisch mit Beinen aus rohem oder lackiertem Stahlblech. Verbundplatte aus Eiche-Massivholz mit sägerauer Oberfläche oder in den handgespachtelten Ausführungen.

Mesa con patas en chapa de acero hierro crudo acabado pintado o lacado. Sobres realizados en madera maciza de roble acabado aserrado o en los acabados de material cepillado a mano.

Table with legs of metal sheet in raw iron finish or lacquered. Top made of solid oak wood with "sawn surface" finishing or covered with hand-spread pastes.

Table avec pieds en acier dans la finition vernis fer brut ou laqué. Plateaux réalisés en chêne massif finition "brut de sciage" ou dans les finitions en matériau brossé à la main.



Fan



dettaglio / detail

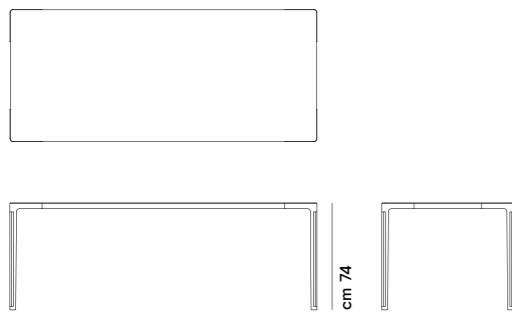

cm 80×150  
cm 85×180  
cm 90×210  
cm 100×240  
cm 140×140

cm 74

## Fourmore

design Gordon Guillaumier  
2020

Tavolo con struttura telaio realizzato in lamiera di acciaio 10 mm tagliata laser, top e prolunga fresati a controllo numerico. Dettagli meccanici in plastica stampata su disegno specifico. Sistemi di scorrimento su guide di alluminio con pattini autolubrificanti.

Tisch mit Gestell aus Stahlblech 10 mm, mit Laser geschnitten, Platte und Ausziehplatte mit Steuerungsprogramm gefräst. Mechanische Komponenten aus formgepresstem Kunststoff. Selbstschmierende Führungsschienen aus Aluminium.

Mesa con estructura en acero de 10 mm, cortada a laser. La encimera y sobre extensible están fresados con máquina de control numérico. Detalles mecánicos en plástico moldeado sobre diseño técnico. Sistema deslizante con guías en aluminio con patines autolubrificantes.

Table with structure made of 10 mm laser-cut steel sheet, CNC-milled top and extension. Mechanical details in moulded plastic on specific design. Sliding systems on aluminium tracks with self-lubricating runners.

Table avec structure en acier 10 mm, coupée au laser, plateau et rallonge fraisés par machine à contrôle numérique. Détails mécaniques en plastique moulée selon design spécifique. Systèmes de glissement sur guides en aluminium avec patins auto-lubrifiants.



Fourmore



dettaglio / detail

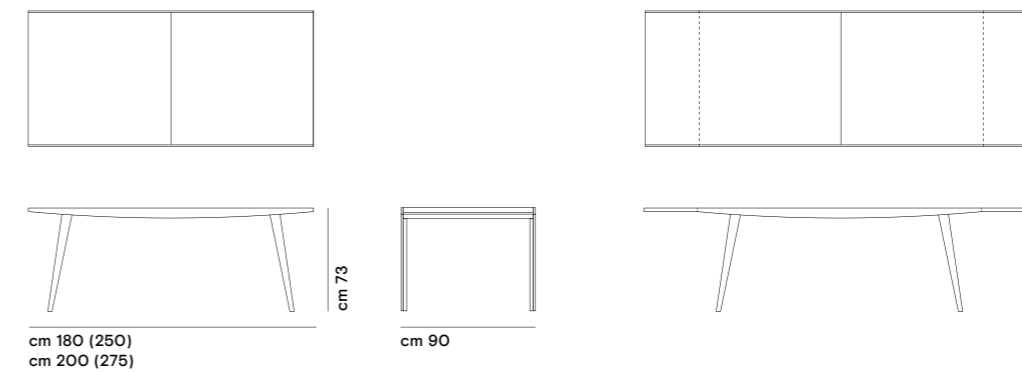

cm 180 (250)  
cm 200 (275)

cm 78

cm 90

allungabile / extending



## Helsinki 30 — home

design Caronni + Bonanomi  
1995

Sistema di tavoli con struttura smontabile in acciaio sezione 30×30 mm e giunti in pressofusione. Struttura nelle finiture laccato opaco oppure nelle finiture esclusive Desalto. Piani in cristallo, laminato Fenix®, laminato stratificato, ceramica o essenza.

Tischsystem mit Stahlgestell, Querschnitt 30×30 mm, Verbindungselemente aus Druckguss. Gestell in den matt lackierten Ausführungen oder in den exklusiven Desalto Ausführungen. Platten aus Glas, Fenix® Laminat, Schichtlaminat, Keramik oder Holz.

Sistema de mesas con estructura desmontable en acero, sección 30×30 mm y juntas en presofusión. Estructura en los acabados lacados mate o en los exclusivos acabados Desalto. Encimeras en cristal, laminado Fenix®, laminado estratificado, cerámica o madera.

Range of tables with disassembling steel frame, section 30×30 mm, and die-cast aluminium joints. Frame in the matt lacquered finishing or in the Desalto's exclusive finishes. Tops available in Glass, Fenix® laminate, layered laminate, ceramic or wooden tops.

Système de tables avec structure démontable en acier, section 30×30 mm, et joints moulés sous pression. Structure dans les finitions mates laquées ou dans les exclusives finitions Desalto. Plateaux en verre, laminé Fenix®, laminé stratifié, céramique ou en bois.

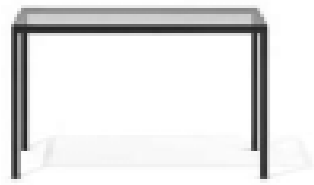

Helsinki 30 — home



dettaglio / detail

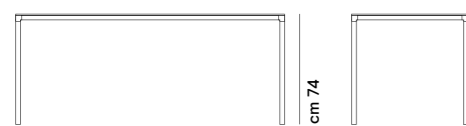

cm 52×78  
cm 52×118  
cm 52×140  
cm 52×170  
cm 78×118  
cm 78×140  
cm 78×170  
cm 52×52  
cm 78×78  
cm 118×118

## Helsinki 30 — home extending

design Caronni + Bonanomi  
2016

Sistema di tavoli con struttura smontabile in acciaio sezione 30×30 mm e giunti in pressofusione. Struttura nelle finiture laccato opaco. Piani in laminato Fenix®, laminato stratificato o essenza.

Tischsystem mit Stahlgestell, Querschnitt 30×30 mm, Verbindungselemente aus Druckguss. Gestell in den matt lackierten Ausführungen. Platten aus Fenix® Laminat, Laminat, Schichtlaminat oder Holz.

Sistema de mesas con estructura desmontable en acero, sección 30×30 mm y juntas en presofusión. Estructura en los acabados lacados mate. Encimeras en laminado Fenix®, laminado, laminado estratificado o madera.

Range of tables with disassembling steel frame, section 30×30 mm, and die-cast aluminium joints. Frame in the matt lacquered finishing. Tops available in Fenix® laminate, laminate, layered laminate or wooden tops.

Système de tables avec structure démontable en acier, section 30×30 mm, et joints moulés sous pression. Structure dans les finitions mates laquées. Plateaux en laminé Fenix®, laminé, laminé stratifié ou en bois.



Helsinki 30 — home extending



dettaglio / detail

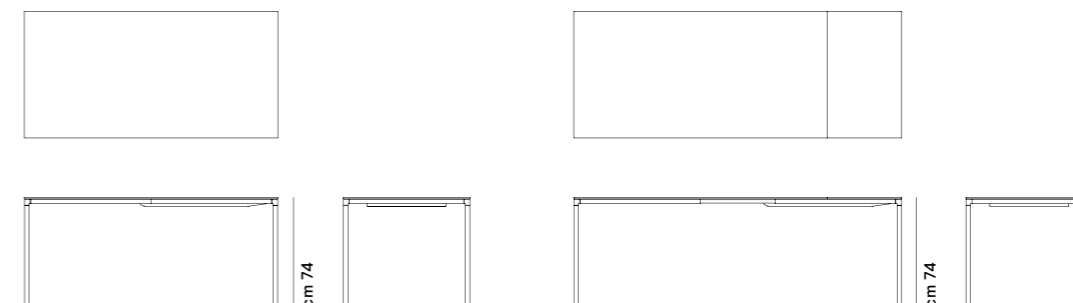

cm 85×118 (168)  
cm 85×140 (190)  
cm 85×170 (220)

allungabile / extending

## Helsinki 35 — home

design Caronni + Bonanomi  
1995

Sistema di tavoli con struttura smontabile in acciaio sezione 35×35 mm e giunti in pressofusione. Struttura nelle finiture laccato opaco oppure nelle finiture esclusive Desalto. Piani in cristallo, laminato Fenix®, laminato stratificato, ceramica o essenza.

Tischsystem mit Stahlgestell, Querschnitt 35×35 mm, Verbindungselemente aus Druckguss. Gestell in den matt lackierten Ausführungen oder in den exklusiven Desalto Ausführungen. Platten aus Glas, Fenix® Laminat, Schichtlaminat, Keramik oder Holz.

Sistema de mesas con estructura desmontable en acero, sección 35×35 mm y juntas en presofusión. Estructura en los acabados lacados mate o en los exclusivos acabados Desalto. Encimeras en cristal, laminado Fenix®, laminado estratificado, cerámica o madera.

Range of tables with disassembling steel frame, section 35×35 mm, and die-cast aluminium joints. Frame in the matt lacquered finishing or in the Desalto's exclusive finishes. Tops available in Glass, Fenix® laminate, layered laminate, ceramic or wooden tops.

Système de tables avec structure démontable en acier, section 35×35 mm, et joints moulés sous pression. Structure dans les finitions mates laquées ou dans les exclusives finitions Desalto. Plateaux en verre, laminé Fenix®, laminé stratifié, céramique ou en bois.



Helsinki 35 — home



dettaglio / detail



cm 90×140  
cm 90×180  
cm 90×200  
cm 90×220  
cm 90×240  
cm 90×299  
cm 100×200  
cm 100×220  
cm 100×240  
cm 100×299  
cm 90×90  
cm 149×149

## Helsinki 35 — home extending

design Caronni + Bonanomi  
2022

Tavolo allungabile con gambe in acciaio sezione 35×35 mm e giunti in pressofusione e telaio in estruso di alluminio. Struttura nelle finiture laccato opaco. Piano e prolunghe con apertura a libro in ceramica.

Ausziehtisch mit Beinen aus Stahl, Sektion 35×35 mm, Verbindungen aus Druckguss und Rahmen aus extrudiertem Aluminium. Gestell in matt lackierten Ausführungen. Platte und Ausziehplatten mit Aufklappen Öffnung aus Keramik.

Mesa extensible con patas de acero de sección 35×35 mm, juntas en presofusión y estructura de aluminio extruido. Estructura en acabados lacados mate. Tapa y extensiones con apertura a libro en cerámica.

Extending table with steel legs, section 35×35mm, die-cast joints and extruded aluminium frame. Structure in matt lacquered finishes. Top and folding leaves in ceramic.

Table à rallonges avec pieds en acier de section 35×35 mm, joints moulés sous pression et cadre en aluminium extrudé. Structure en finitions laquées mates. Plateau et rallonges à fermeture portefeuille en céramique.



Helsinki 35 — home extending

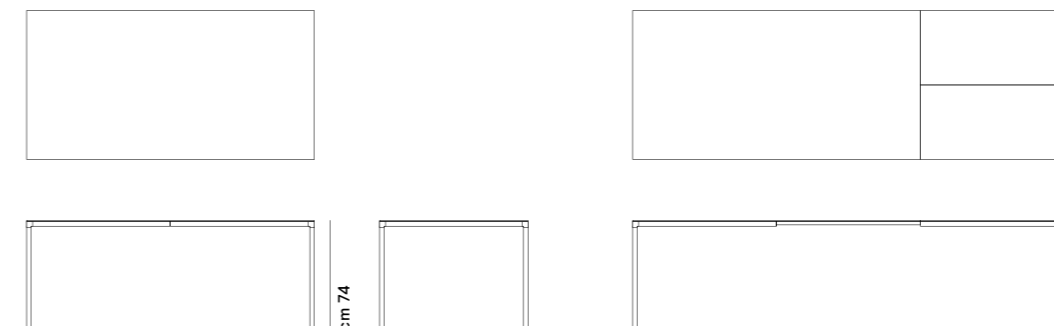

cm 85×170 (250)  
cm 100×170 (250)  
cm 100×200 (300)

allungabile / extending

## Helsinki 35 — office

design Caronni + Bonanomi  
1995

Sistema di tavoli con struttura smontabile in acciaio sezione 35×35 mm e giunti in pressofusione. Struttura nelle finiture laccato opaco. Piani in laminato Fenix®, laminato stratificato, ceramica o essenza.

Tischsystem mit Stahlgestell, Querschnitt 35×35 mm, Verbindungselemente aus Druckguss. Gestell in den matt lackierten Ausführungen. Platten aus Fenix® Laminat, Schichtlaminat, Keramik oder Holz.

Sistema de mesas con estructura desmontable en acero, sección 35×35 mm y juntas en presofusión. Estructura en los acabados lacados mate. Encimeras en laminado Fenix®, laminado estratificado, cerámica o madera.

Range of tables with disassembling steel frame, section 35×35 mm, and die-cast aluminium joints. Frame in the matt lacquered finishing. Tops available in Fenix® laminate, layered laminate, ceramic or wood.

Système de tables avec structure démontable en acier, section 35×35 mm, et joints moulés sous pression. Structure dans les finitions mates laquées. Plateaux en laminé Fenix®, laminé stratifié, céramique ou en bois.

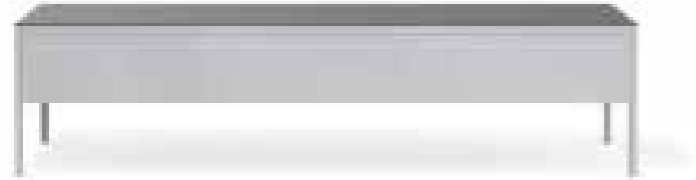

Helsinki 35 — office



dettaglio / detail



cm 90×140  
cm 90×180  
cm 90×200  
cm 90×220  
cm 90×240  
cm 90×299  
cm 100×200  
cm 100×220  
cm 100×240  
cm 100×299

cm 74

## Helsinki 35 — outdoor

design Caronni + Bonanomi  
1995

Sistema di tavoli con struttura smontabile in acciaio sezione 35×35 mm, e giunti in pressofusione. Piani in laminato stratificato o ceramica. Panche con struttura smontabile in acciaio, sezione 35×35 mm e giunti in pressofusione. Piano in laminato stratificato.

System von Tischen mit zerlegbarem Stahlgestell, Querschnitt 35×35 mm und Verbindungselemente aus Druckguss. Platten aus Schichtlaminat oder Keramik. Hocker-Bank aus Stahlgestell, Querschnitt 335×35 mm, Verbindungselemente aus Druckguss. Platten aus Schichtlaminat.

Sistema de mesas con estructura desmontable en acero, sección 35×35 mm, y juntas en presofusión. Sobres en laminado estratificado o cerámica. Bancos con estructura desmontable en acero, sección 35×35 mm, y juntas en presofusión. Sobres en laminado estratificado.

Range of tables with disassembling steel frame, section 35×35 mm, and die-cast aluminium joints. Layered laminate or ceramic tops. Benches with steel frame (section 35×35 mm), and die-cast aluminium joints. Layered laminate top.

Système de tables avec structure démontable en acier, section 35×35 mm, et joints moulés sous pression. Plateaux en laminé stratifié ou céramique. Bancs avec structure démontable en acier, section 35×35 mm, et joints moulés sous pression. Plateau en laminé stratifié.



Helsinki 35 Outdoor

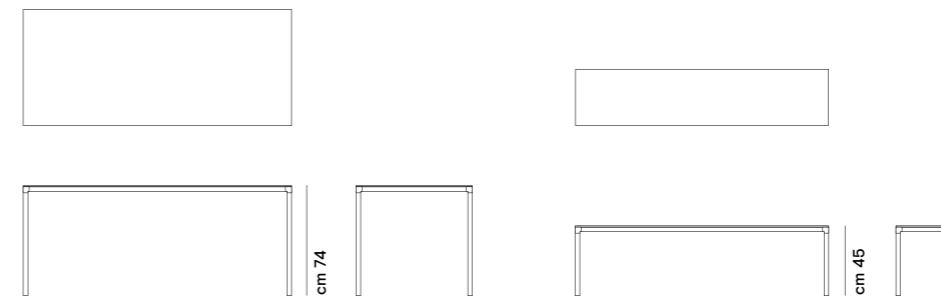

cm 90×140  
cm 90×180  
cm 90×200  
cm 90×220  
cm 90×240  
cm 90×299

cm 100×200  
cm 100×220  
cm 100×240  
cm 100×299  
cm 90×90  
cm 149×149

cm 100×36  
cm 130×36  
cm 160×36

cm 74

cm 45

tavolo / table

panca / bench

## Iblea

design Gordon Guillaumier  
2007

Tavolo con base in acciaio spessore 15 mm, struttura laccata o in finitura galvanica. Top in marmo (spessore 20 mm). Top in cristallo o ceramica con sottotop in MDF laccato grafite.

Tisch mit Stahlgestell 15 mm Stärke, Gestell lackiert oder mit galvanischer Ausführung. Marmorplatten (Stärke 20 mm). Platte aus Glas oder aus Keramik mit MDF Unterhalterung, lackiert grafite.

Mesa con base de acero de 15 mm de espesor. Estructura lacada o con acabado galvanizado. Encimeras de mármol (espesor 20 mm). Encimeras en cristal o en cerámica con parte inferior de MDF lacado grafite.

Table with steel base, 15 mm thick, with lacquered or galvanized finish. Tops in marble (thickness 20 mm). Top in glass or ceramic with MDF undertop support, grafite lacquered.

Table avec base en acier épaisseur 15 mm, structure laquée ou avec finition galvanique. Plateaux en marbre (épaisseur 20 mm). Plateau en verre ou en céramique avec support sous plateau en MDF laqué grafite.

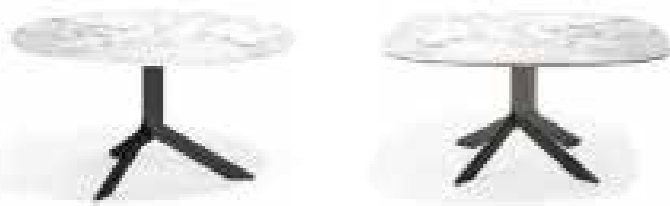

Iblea

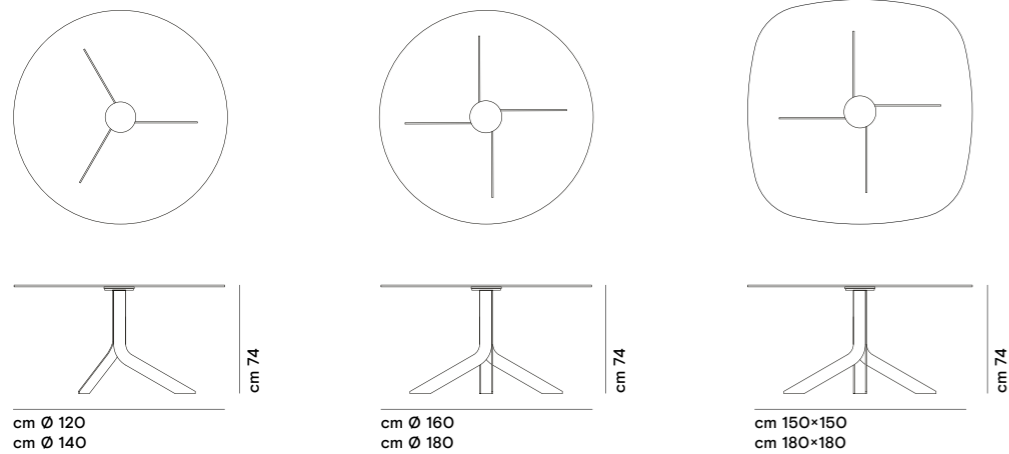

## Icaro O15

design Caronni + Bonanomi  
2015

Tavolo, tavolino e console con struttura e cassetti in acciaio, piani in cristallo temperato da 8 mm oppure in ceramica da 6 mm. Cassetti montati su guide a sfera ad estrazione totale. Portaoggetti per interno cassetti in neoprene lavabile di colore nero (optional).

Tische, Couchtische und Konsole mit Gestell und Schubladen aus Stahl in den Ausführungen, temperierte Glasplatten 8 mm oder aus Keramik 6 mm. Schubladen mit Vollauszug. Optional Schubladeneinsätze aus schwarzem Neopren.

Mesas, mesitas y consolas con estructura y cajones en acero, sobres en cristal templado 8 mm o en cerámica 6 mm. Cajones montados sobre guías esféricas de extracción total. Porta-objetos internos para cajones en neopreno lavable en color negro (opcional).

Tables, small tables and consoles with steel frame and drawers, tops in toughened glass 8 mm or ceramic 6 mm. Drawers on full extension ball bearing slides. Drawers storage accessories in washable black neoprene (optional).

Tables, tables basses et consoles avec structure et tiroirs en acier, plateaux en verre trempé 8 mm ou en céramique 6 mm. Tiroirs montés sur charnières coulissantes à roulement à extraction totale. Porte-objets pour l'intérieur des tiroirs en néoprène lavable, en couleur noir (en option).



Icaro O15



dettaglio / detail

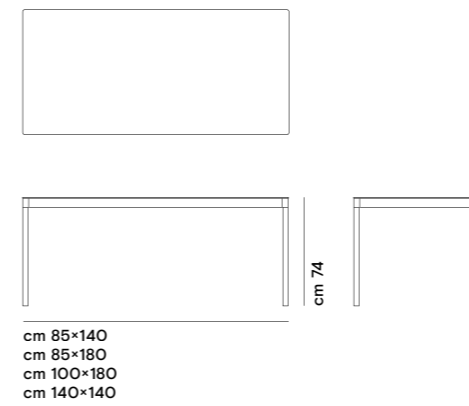

## Kobe

design Piergiorgio Cazzaniga  
2011

Tavolo con base in pressofusione di alluminio e tubo in acciaio. Piano in laminato stratificato bianco, nero o laccato. Basamento laccato nelle stesse finiture del piano.

Tisch mit Basis aus Aluminiumdruckguss und Stahlrohr. Tischplatte aus Schichtlaminat in schwarz, weiss oder lackiert. Basis lackiert in der gleichen Ausführung wie die Platte.

Mesa con base en presofusión de aluminio y tubo en acero. Sobre en estratificado negro, blanco o lacado. Base lacado en los mismos acabados que el sobre.

Table with die-cast aluminium base and steel tube. Layered laminate top, available in black or white colour, or lacquered. Lacquered base in the same finishes as the top.

Table avec base en aluminium moulée sous pression et tube en acier. Plateau en laminé stratifié noir, blanc ou laqué. Base laquée dans les mêmes finitions que le plateau.

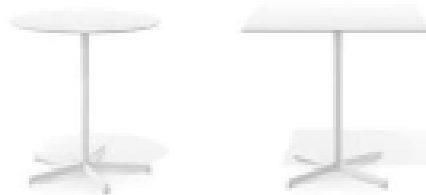

Kobe



cm Ø 60  
cm Ø 69  
cm Ø 79



cm 69×69



cm 72



cm 72

## L45

design Guglielmo Poletti  
2020

Tavolo e tavolino con gambe in angolare di acciaio spessore 6 mm lavorate a controllo numerico, telaio in angolare di acciaio con spessore 5 mm lavorato a controllo numerico. Top in legno, poliestere o spatolato cemento.

Tisch und Couchtisch mit eckigen Stahlbeine, Materialstaerke 6 mm, mit Steuerungsprogramm bearbeitet, Rahmen aus Stahlwinkeln Materialstaerke 5 mm, ebenfalls mit Steuerungsprogramm bearbeitet. Top aus Holz, Polyester oder mit Zement bezogen.

Mesa y mesita con patas angulares en acero de 6 mm, moldeadas con máquina de control numérico, estructura también en acero con espesor 5 mm, y moldeada con máquina de control numérico. Top en madera, en poliéster o en cemento aplicado a mano con espátula.

Tables and small tables collection with angular steel legs, 6 mm thickness, CNC-machined. Frame in angular steel with 5 mm thickness, CNC-machined. Honeycomb top with solid wood, polyester or hand-spread concrete finishes.

Table et table basse avec pieds angulaires en acier, 6 mm travaillé avec machine à contrôle numérique, cadre angulaire en acier 5 mm d'épaisseur travaillé avec machine à contrôle numérique. Plateau en bois, en polyester ou recouvert de ciment étalé à la main.



L45



dettaglio / detail

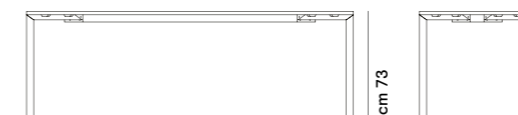

cm 73

cm 140×85  
cm 180×90  
cm 200×90  
cm 240×90  
cm 300×100  
cm 180×180

## Lake

design Gordon Guillaumier  
2018

Tavolo realizzato in tubi di acciaio Ø 30 mm. Top in legno o ceramica ovale, sottotop in MDF laccato grafite.

Tisch hergestellt mit Stahlröhren Ø 30 mm. Ovale Holzplatte oder Keramikplatte, Untereplatte aus MDF, lackiert grafite.

Mesa con estructura en tubos de acero de Ø 30 mm. Encimera ovalada en madera o cerámica, sobre un soporte en MDF lacado grafite.

Table with steel tubes Ø 30 mm, wood or ceramic top in oval shape and MDF under-top support lacquered graphite.

Table avec tubes d'acier Ø 30 mm. Plateau ovale en bois o céramique, support sousplateau en MDF laqué grafite.

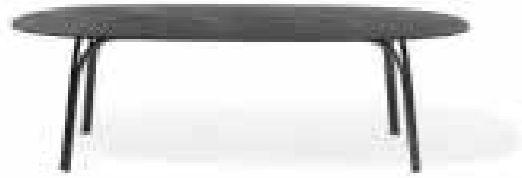

Lake



dettaglio / detail

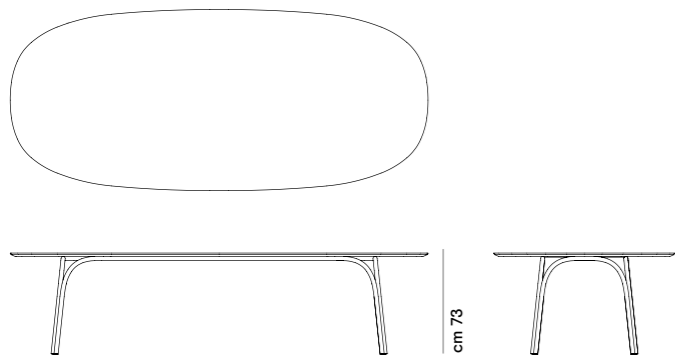

cm 115×200  
cm 120×240  
cm 130×300

cm 73

## Liko Glass

design Arik Levy  
2004

Tavolo smontabile con piano in cristallo temperato e gambe in acciaio.

Tisch mit temperierter Glasplatte und Stahlbeinen.

Mesa desmontable con encimera en cristal templado y patas en acero.

Disassembling table with toughened glass top and steel legs.

Table démontable avec plateau en verre trempé et pieds en acier.



Liko Glass



dettaglio / detail

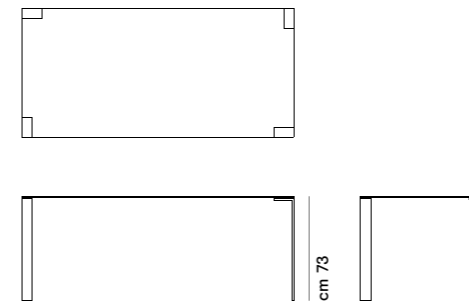

cm 119×79  
cm 150×79  
cm 190×90  
cm 220×90  
cm 99×99

cm 73

[Link](#)

design Hannes Wettstein  
2000

Tavolo modulare con struttura smontabile in acciaio trafilato e giunti in pressofusione di alluminio. Supporti del piano e piedini in acciaio inox, entrambi regolabili. Piani in cristallo.

Modularer Tisch mit Stahlgestell und Verbindungselementen aus Druckguss. Verstellbare Halterungen und Füßchen aus Edelstahl. Platte aus Glas.

Mesa modular con estructura desmontable en trafilado de acero y juntas en fusión de aluminio. Soportes de encimera y pies en acero inox, ambos regulables. Encimera en cristal.

Modular table with disassembling drawn steel frame, and die-cast aluminium joints. Adjustable feet and top support plates in stainless steel. Glass tops.

Table modulaire avec structure démontable en tube d'acier tréfilé et joints moulés sous pression. Supports pour plan et pieds en acier inox, réglables. Plateaux en verre.



[Link](#)

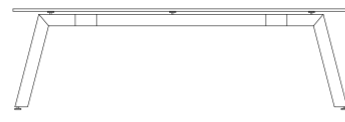
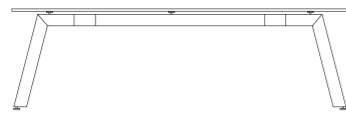
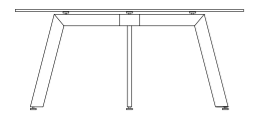
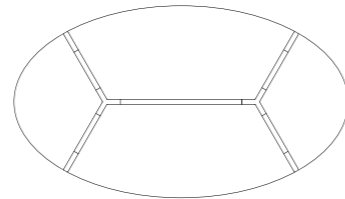
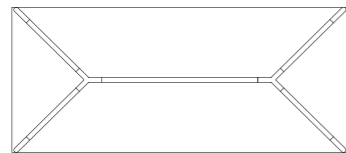
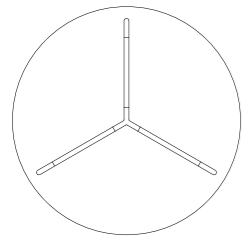
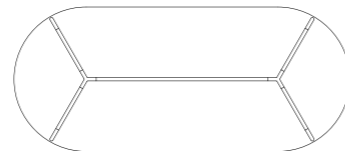
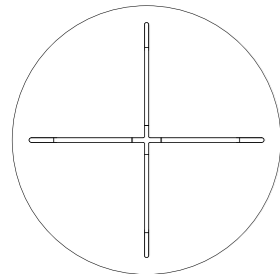

cm Ø 140  
cm Ø 158  
cm Ø 180

cm 90×180  
cm 90×205  
cm 105×220  
cm 140×140

cm 115×200  
cm 129×245

cm 74

cm 74

cm 74

[Link](#)

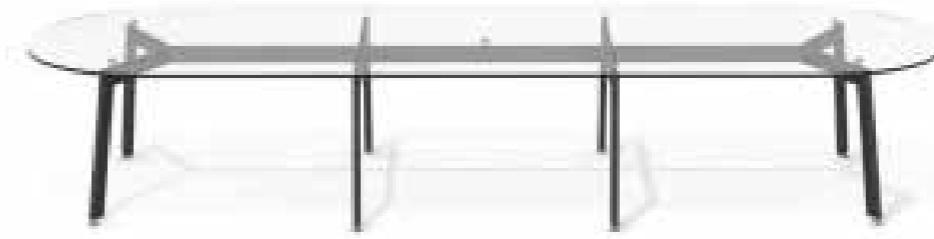

Example of composition

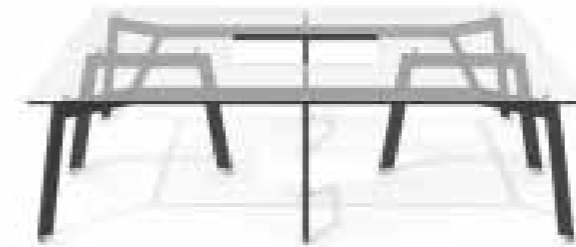

Example of composition

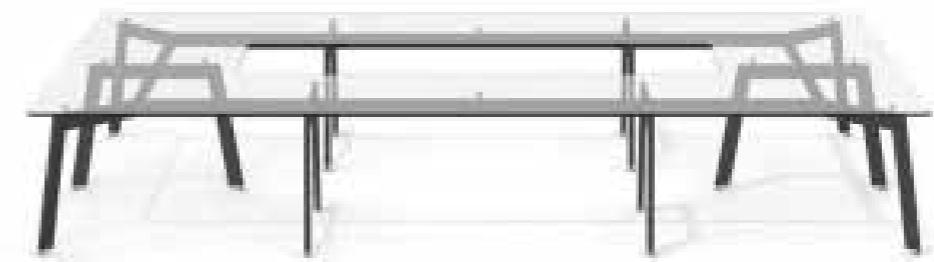

Example of composition

## Mac

design Pierluigi Cerri  
2007

Tavolo con struttura in alluminio estruso e giunti strutturali in pressofusione. Piani in cristallo temperato da 8 mm o ceramica, interamente incassati a filo della struttura. Disponibile nelle versioni indoor e outdoor.

Tisch mit Gestell aus Fließpressaluminium und Verbindungselementen aus Druckguss. Eingebaute Tischplatte aus temperiertem Glass 8 mm oder Keramik. Verfügbar für In- und Outdoor.

Mesa con estructura en aluminio extrudido y juntas estructurales en presofusión. Sobres en cristal 8 mm templado o cerámica, totalmente y precisamente cobrado. Disponible en las versiones de interior y de exterior.

Table with extruded aluminium frame and die-cast structural joints. Built-in tops of 8 mm toughened glass or ceramic. Available in indoor and outdoor versions.

Table avec structure en aluminium extrudé et joints de connexion moulés sous pression. Plateaux en verre trempé 8 mm ou céramique, complètement et précisément encastré. Disponible dans les versions pour intérieur et extérieur.



Mac

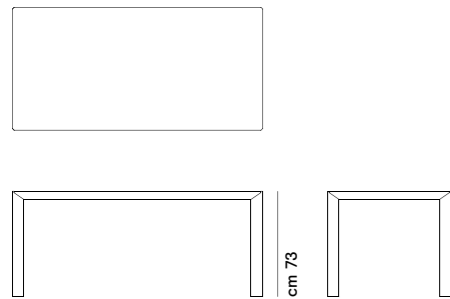

cm 85×160  
cm 100×200  
cm 100×240  
cm 100×300  
cm 149×149

## MM8

design Guglielmo Poletti  
2019

Tavolo con top laccato a polvere realizzato in alluminio spessore 8 mm con bordo sagomato e doppia base cilindrica.

Tisch mit Platte aus Aluminium 8 mm Stärke Pulverbeschichtet mit geformter Kante und Zylindrischer Doppelbasis.

Mesa con encimera lacada en polvo realizada en aluminio espesor 8 mm con borde moldeado y doble base cilíndrica.

Table with powder coated aluminium top 8 mm thickness, with shaped edge and cylindrical double base.

Table avec plateau laqué à poudre réalisé en aluminium épaisseur 8 mm avec bord moulée et double base cylindrique.



MM8

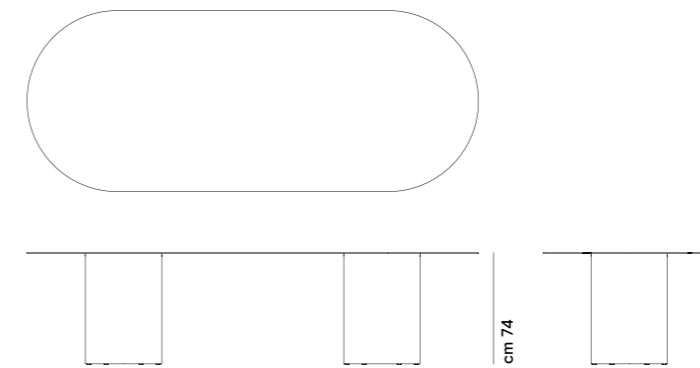

cm 110×240  
cm 120×299



## Skin

design Marco Acerbis  
2015

Tavolo fisso o allungabile con struttura in alluminio estruso. Piani da 6 mm in cristallo temperato o ceramica. Nella versione allungabile, prolunga con apertura a libro nello stesso materiale del piano. La versione fissa, in alcune varianti, è utilizzabile anche per outdoor.

Tisch, fix oder ausziehbar, mit Gestell aus extrudiertem Aluminium. Platten aus temperiertem Glas oder Keramik 6 mm. In der ausziehbaren Version, hat die Ausziehplatte mit Klapptür das gleiche Material der Hauptplatte. Die Version nicht ausziehbar ist in bestimmten Ausführungen auch für Outdoor geeignet.

Mesa fija o extensible con estructura en aluminio extruido. Encimeras en cristal templado o en cerámica 6 mm. En la versión extensible, la extensión a libro es en el mismo material y acabado que la encimera. En la versión fija, en algunos acabados, la mesa es apta también para uso en el exterior.

Fix or extendible table with extruded aluminium frame. Tops of toughened glass or ceramic 6 mm. In the extendible version, folding leaves in the same material as the top. The fixed table, in some versions, is suitable also for outdoor use.

Table fixe et à rallonges avec structure en aluminium extrudé. Plateaux en verre trempé ou céramique 6 mm. Dans la version à rallonges, rallonge à fermeture portefeuille dans le même matériau que le plateau. La version fixe, dans quelques variantes, peut être aussi utilisée à l'extérieur.



Skin

dettaglio / detail

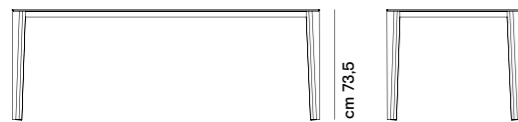

cm 73,5

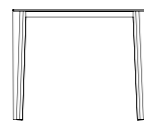

cm 85×140  
cm 85×170  
cm 100×200  
cm 100×300  
cm 140×140  
cm 200×200



cm 73,5

cm 85×170 (250)  
cm 100×170 (250)  
cm 100×200 (300)

fisso / fixed

allungabile / extending

## Strong

design Eugeni Quitlet  
2019

Tavolo con struttura in tubolare di acciaio curvato Ø 60 mm. Top in legno, o nelle finiture materiche spatolate a mano.

Tisch mit Gestell aus gebogenem Stahlrohr Ø 60 mm. Top aus Holz oder in den handgebürsteten Materialoberflächen.

Mesa con estructura en tubo de acero curvado diámetro 60 mm. Top en madera o matérico espatulado.

Table with folded tubular steel frame Ø 60 mm. Top with solid wood, or covered with hand-spread materic finishes.

Table avec structure en tubulaire d'acier cintré diamètre 60 mm. Plateau en bois ou dans les finitions matériaux spatulés.



Strong

dettaglio / detail

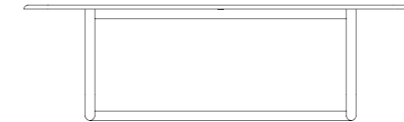

cm 74

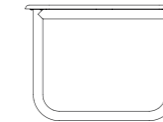

cm 100×200  
cm 100×250  
cm 109×300

## Strong

design Eugeni Quitllet  
2019

Tavolo bistrot con struttura in tubo di acciaio curvato Ø 60 mm. Top in: lamiera di acciaio tornita, rovere massello, marmo (spessore 30 mm).

Bistrottisch mit Gestell aus Stahlrohr Ø 60 mm. Platte aus: gedrehtes Stahlblech, Eiche Massivholz, Marmor (Stärke 30 mm).

Mesa bistrot con estructura en tubo de acero curvado diámetro 60 mm. Encimera en: chapa de acero torneada, roble macizo, mármol (espesor 30 mm).

Bistrot table with frame in folded steel tube Ø 60 mm. Tops in: turned steel sheet, solid oak, marble (30 mm thickness).

Table bistrot avec structure en tube d'acier courbé diamètre 60 mm. Plateau en: feuille d'acier cintré, chêne massif, marbre (épaisseur 30 mm).



Strong

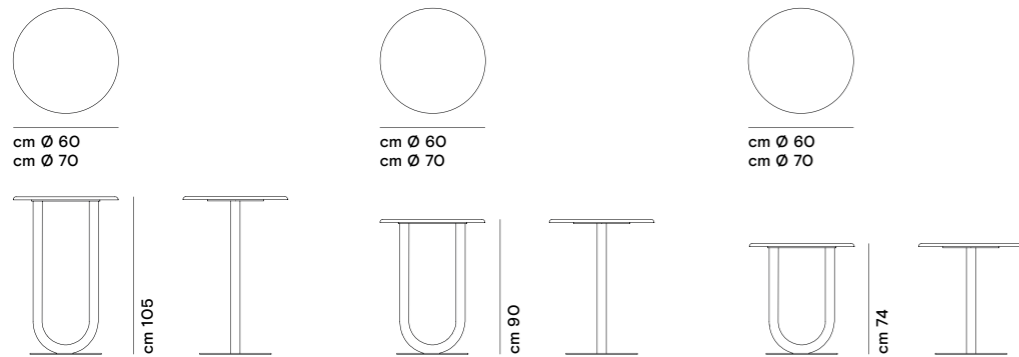

## Tender

design Decoma Design  
1988

Tavolo allungabile con gambe in pressofusione di alluminio e tubi in acciaio. Piani in cristallo.

Ausziehbarer Tisch mit Beinen aus Preßgussaluminium und Stahlrohren. Tischplatte aus Glas.

Mesa extensible con patas en presofusión de aluminio y tubos en acero. Sobres en cristal.

Extending table with die-cast aluminium frame and steel tubes. Tops of glass.

Table à rallonges avec pieds en fusion d'aluminium et tubes en acier. Plateaux en verre.



Tender

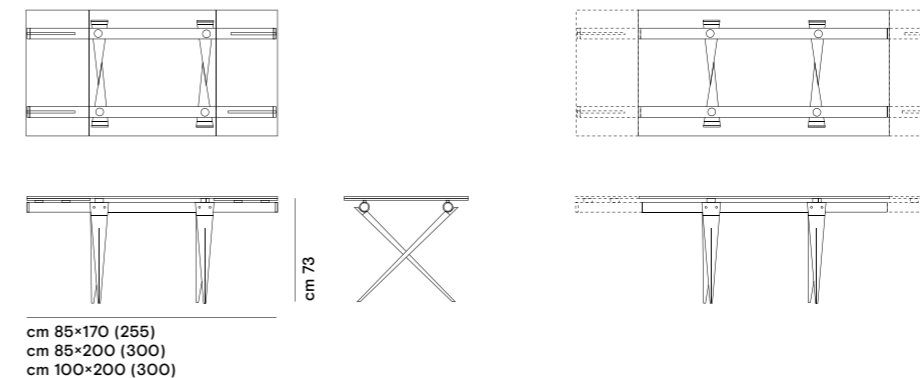

allungabile / extending

288

design Poggi + Dondoli  
2009

Sedia impilabile in nylon. Stampata con tecnologia air moulding, adatta anche per uso esterno.

Stapelbarer Stuhl aus Nylon. Pressguss-Verfahren mit "air moulding -Technologie", geeignet auch für Outdoor.

Silla apilable en nylon. Moldeada con tecnología air moulding, idónea también para el uso en el exterior.

Nylon stacking chair moulded with "air-moulding" technology, it is also suitable for outdoor use.

Chaise empilable en nylon. Moulée avec technologie air moulding, utilisable aussi à l'extérieur.



288

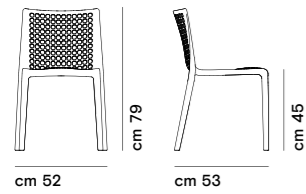

Aria

design Atelier Oï  
2019

Lounge chair con struttura in tubolare di acciaio e seduta in rete elastica. Supporto anteriore in piatto di acciaio laccato.

Lounge chair mit Gestell aus Stahlrohr und Sitz aus elastischem Netz. Vordere Halterung aus lackierter Stahlplatte.

Silla lounge con estructura en tubo de acero y asiento en red elástica. Soporte anterior en placa de acero lacado.

Lounge chair with tubular steel frame and seat in elastic net. Front support in lacquered steel plate.

Chaise lounge avec structure en tubulaire d'acier et assise en maille élastique. Support antérieur en assiette d'acier laqué.



Aria

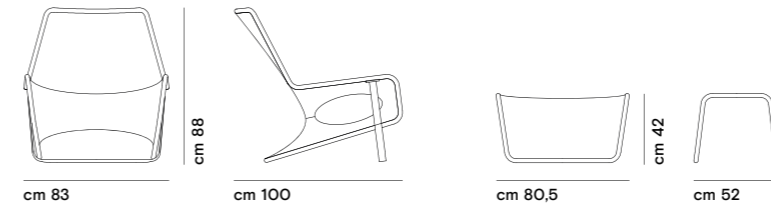

Famiglia di sedute da ufficio con sedile in poliuretano rigido e imbottitura in schiumato. Braccioli in alluminio stampato oppure imbottiti in poliuretano con struttura interna in acciaio. Base girevole in alluminio dotata di meccanismo per la regolazione dell'altezza e inclinazione della seduta a 4 razze oppure nella versione a 5 razze con ruote autofrenanti.

Familie von Bürostühlen mit Sitz aus hartem Polyurethan und Schaumstoffpolsterung. Armlehnen aus geformtem Aluminium oder gepolstert aus Polyurethan mit Innenstahlstruktur. Drehgestell aus Aluminium, ausgestattet mit Höhenverstellung-Mechanismus und Sitzneigung, mit 4 Kreuzgestell oder mit 5 Kreuzgestell mit selbstbremsenden Rädern.

Familia de sillas de oficina con asiento en poliuretano rígido y acolchado de espuma. Reposabrazos en aluminio moldeado o acolchados en poliuretano con estructura interna de acero. Base giratoria de 4 radios de aluminio, equipada con mecanismo para regular la altura y la inclinación del asiento, o base de 5 radios con ruedas autofrenantes.

Family of office chairs with seat in rigid polyurethane and foam padding. Armrests in molded aluminum or padded in polyurethane with internal steel structure. Swivel base in aluminum equipped with mechanism for adjusting the height and seat inclination, with 4-star or 5-star base, self-braking wheels.

Famille de chaises de bureau avec assise en polyuréthane rigide et rembourrage en mousse. Accoudoirs en aluminium moulé ou rembourrés en polyuréthane avec structure interne en acier. Base pivotante à 4 branches en aluminium, équipée d'un mécanisme pour régler la hauteur et l'inclinaison de l'assise, ou dans la version à 5 branches avec roulettes auto-freinantes.



President  
4-Star base

Executive  
4-Star base

Task  
4-Star base

dettaglio / detail

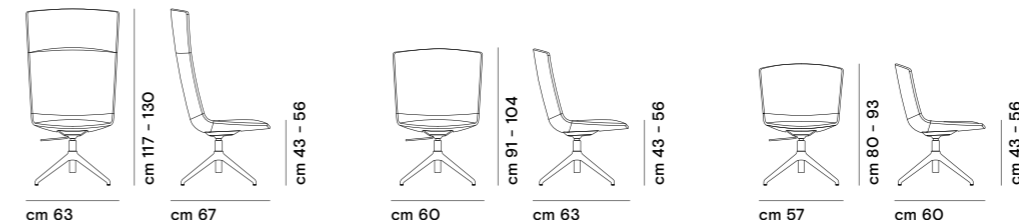

President  
5-Star base

Executive  
5-Star base

Task  
5-Star base

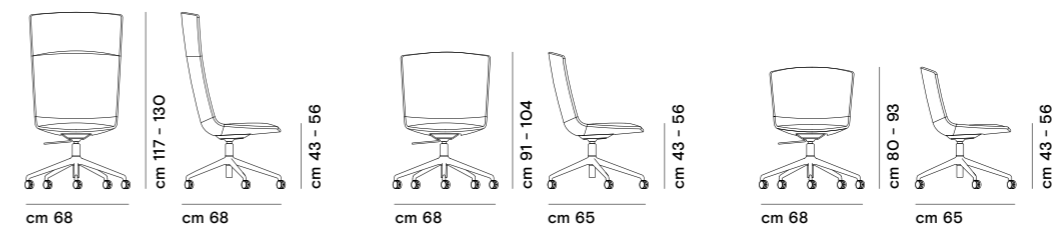

## Calum Home

design Simon Pengelly  
2022

Famiglia di sedute con sedile stampato in poliuretano rigido e imbottitura in schiumato. Braccioli imbottiti in poliuretano con struttura interna in acciaio. Base a slitta in tondino di acciaio, 4 gambe legno, cantilever in tubo di acciaio oppure a 4 razze girevole.

Family of chairs with seat in rigid polyurethane and foam padding. Armrests in molded aluminum or padded in polyurethane with internal steel structure. Rod steel sled base, 4 wooden legs, cantilever in rod steel or swivel 4-star base.

Familie von Stühlen mit Sitz aus hartem Polyurethan und Schaumstoffpolsterung. Armlehnen aus gepolstertem Polyurethan mit Innenstahlstruktur. Kufengestell aus Stahlrohr, 4 Holzbeine, Cantilever aus Stahlrohr oder drehbar mit 4 Kreuzfüsse.

Famille de sièges avec assise moulée en polyuréthane rigide et rembourrage en mousse. Accoudoirs rembourrés en polyuréthane avec structure interne en acier. Piètement luge en tube d'acier, 4 pieds en bois, base cantilever en tube d'acier ou à 4 branches pivotantes.

Familia de sillas con asiento moldeado en poliuretano rígido y acolchado de espuma. Reposabrazos acolchados en poliuretano con estructura interna de acero. Base trineo en tubo de acero, 4 patas de madera, base en voladizo en tubo de acero o con 4 radios giratorios.



Base 4 razze / 4-Star base      Slitta / Sled base      Cantilever      Legno / Wood



dettaglio / detail

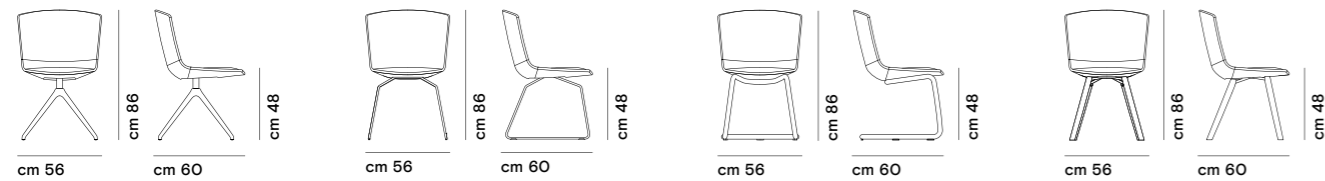

## Calum Lounge

design Simon Pengelly  
2022

Famiglia di sedute con sedile stampato in poliuretano rigido e imbottitura in schiumato. Braccioli imbottiti in poliuretano con struttura interna in acciaio. Base girevole in alluminio dotata di meccanismo per la regolazione dell'inclinazione della seduta a 4 razze. Pouf con base a 4 razze in alluminio.

Family of chairs with seat in rigid polyurethane and foam padding. Armrests in molded aluminum or padded in polyurethane with internal steel structure. Swivel base in aluminum equipped with seat inclination mechanism, with 4-star base. Pouf with 4-star aluminium base.

Familie von Stühlen mit Sitz aus hartem Polyurethan und Schaumstoffpolsterung. Armlehnen aus gepolstertem Polyurethan mit innenstahlstruktur. Drehgestell aus Aluminium, ausgestattet mit Sitzneigung Mechanismus, mit 4 Kreuzgestell. Pouf mit 4 Kreuzgestell aus Aluminium.

Famille de sièges avec assise moulée en polyuréthane rigide et rembourrage en mousse. Accoudoirs rembourrés en polyuréthane avec structure interne en acier. Base pivotante à 4 branches en aluminium, équipée d'un mécanisme de réglage de l'inclinaison de l'assise. Pouf avec base à 4 branches en aluminium.

Familia de sillas con asiento moldeado en poliuretano rígido y acolchado de espuma. Reposabrazos acolchados en poliuretano con estructura interna de acero. Base giratoria de 4 radios de aluminio, equipada con mecanismo de regulación de la inclinación del asiento. Pouf con base de 4 radios de aluminio.



Relax      Comfort      Footrest



dettaglio / detail

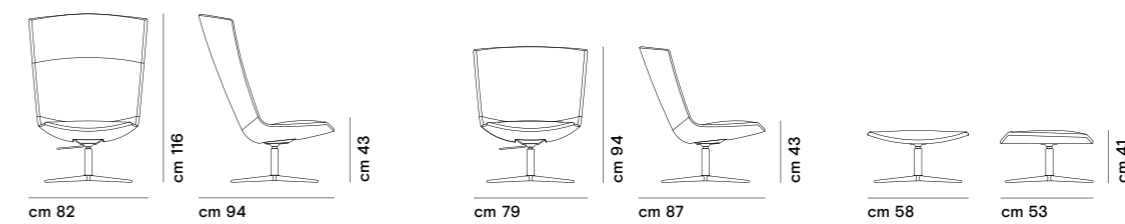

## Endless

design Arik Levy  
2017

Sgabello con basamento in tondino di acciaio laccato, oppure nelle finiture esclusive Desalto. Sedile in multistrato laccato, rivestito o essenza rovere. Il poggiatesta è protetto da un profilo di acciaio inox, tranne nella versione con basamento cromato.

Hocker mit Sockel aus lackiertem Stahlrohr oder in den Desalto exklusiven Ausführungen. Sitz aus lackiertem MDF, bezogen oder mit Eichenholz bezogen. Der Fusstutz ist mit einer Abdeckung aus Edelstahl bezogen (außer der Version mit verchromtem Gestell).

Taburete con estructura en tubo de acero lacado, o en los acabados exclusivos Desalto. Asiento en MDF lacado, tapizado o revestido de roble. El reposapiés es recubierto de un perfil en acero inox, excepto en la versión con la estructura cromada.

Stool with base in lacquered steel rod, or in the Desalto exclusive finishes. Lacquered MDF seat, coated or oak veneered. The footrest is covered with a stainless steel profile, except for the chromed frame version.

Tabouret avec base en tube d'acier laqué, ou dans les finitions exclusives Desalto. Assise en MDF laqué, recouvert ou revêtu en chêne. Le repose-pied est protégé par une couverture en acier inox, sauf que dans la version avec structure chromée.



Endless

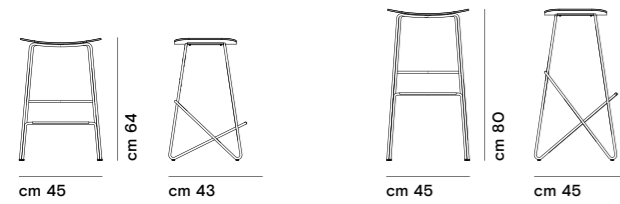

## Flan

design Pocci + Dondoli  
2008

Sgabello con struttura in tondino di acciaio cromato e seduta in nylon.

Tabouret avec structure en tige en acier chromé et assise en nylon.

Taburete con estructura de varilla de acero cromado y asiento de nailon.

Stool with chromed steel rod frame and nylon seat.

Hocker mit Stangenrahmen aus verchromtem Stahl und Nylonsitz.



Flan

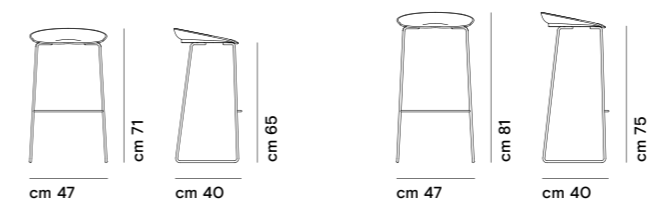

## Kobe

design Piergiorgio Cazzaniga  
2011

Sistema di sedute e sgabello con scocca in BAYDUR®, con o senza braccioli. Struttura a 4 gambe in tubi di acciaio, tondino di acciaio o base girevole ad altezza variabile.

System von Stühlen und Hocker mit Sitzschale aus BAYDUR®, mit oder ohne Armlehne. Struktur mit 4 Beinen aus Rundstahl, Kufengestell oder mit drehbarer Höhenverstellbarbasis.

Seating system and barstool with shell of BAYDUR®, with or without armrests. Frame with 4 legs of steel tube, steel rod or swivelling base with adjustable height.

Système de chaises et tabourets avec coque en BAYDUR®, avec ou sans accoudoirs. Structure avec 4 pieds en tube acier, traîneau en tube d'acier ou base pivotante à hauteur variable.



Kobe



Kobe

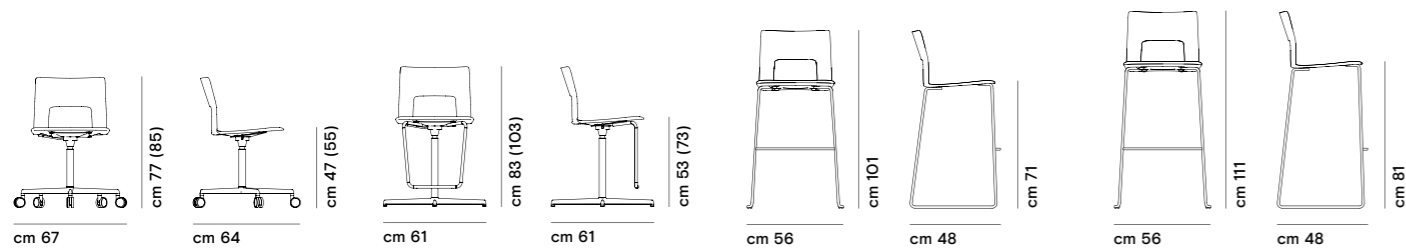
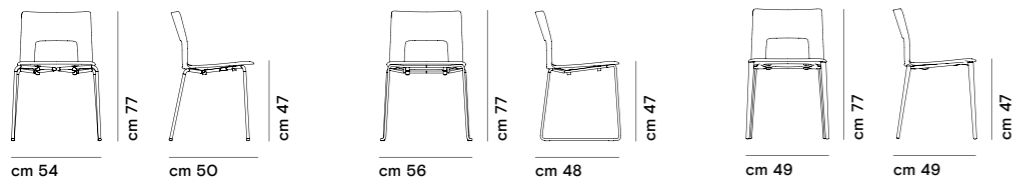

dettaglio / detail

## Koki

design Pocci + Dondoli  
2015

Sedia impilabile e sgabelli con scocca autoportante in poliuretano integrale contenente una struttura in acciaio. Verniciatura realizzata in stampo nelle tonalità goffrate a campionario. Gambe di acciaio in tubolare conico a sezione quadra laccate negli stessi colori della scocca.

Stapelbarer Stuhl und Hocker mit selbsttragender Sitzschale aus integralem Polyurethan und Innengestell aus Stahl, hergestellt in den Farben der Musterliste. Beine aus konischem Rohr mit quadratischem Abschnitt, lackiert in der gleichen gaufrierten Farbe der Sitzschale.

Silla apilable y tabouret con casco en poliuretano integral barnizado en molde, con estructura interna en acero. Disponible en los colores gofrados de la colección. Patas en acero cónico con sección cuadrada lacadas en los mismos colores que el casco.

Stacking chair and stool with self-supporting body in integral polyurethane, containing a steel frame. Mould-coating available in the different embossed colours as per sample collection. Steel legs in tubular conic shape, square section, lacquered in the same colours as the frame.

Chaise empilable et tabouret avec coque autoportante en mousse de polyuréthane intégrale et structure intérieure en acier. Laquage au moulage dans les couleurs gaufrées en collection. Pieds tubulaire en acier à section carrée conique dans les mêmes couleurs que la coque.



Koki

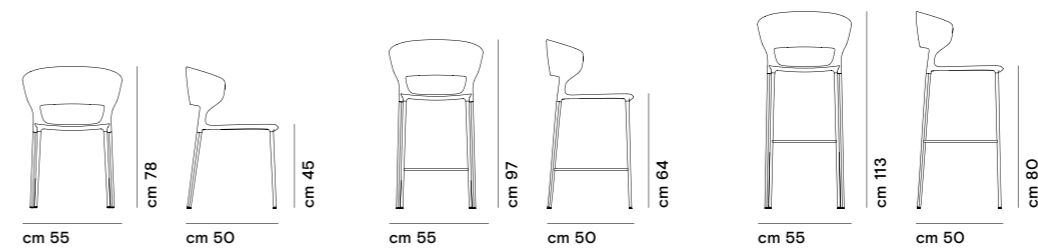

## Koki Wire

design Pocci + Dondoli  
2021

Famiglia di sedute outdoor. Struttura in tondino di acciaio verniciato o, in versione indoor, anche nelle esclusive finiture Desalto. Sedia e sgabello sono impilabili. Tutti i prodotti sono disponibili anche con cuscino in poliuretano integrale o imbottito.

Outdoor-Sitzgruppe. Struktur aus lackiertem Stahlrohr oder in der Indoor-Version auch in den Desalto exklusiven Ausführungen. Stuhl und Hocker sind stapelbar. Alle Produkte sind auch mit Kissen aus integriertem Polyurethan oder gepolstert erhältlich.

Familia de asientos para el exterior. Estructura en tubo de acero lacado o en la versión interior también en los acabados exclusivos Desalto. La silla y los taburetes son apilables. Todos los productos también están disponibles con un cojín de poliuretano integral o acolchado.

Outdoor seating family. Frame in lacquered steel rod or, in the indoor version, also in the Desalto exclusive finishes. Chair and stools are stackable. All products are also available with an integral polyurethane or upholstered cushion.

Famille de sièges d'extérieur. Structure en tube d'acier laqué ou, pour la version intérieure, également dans les finitions exclusives Desalto. La chaise et les tabourets sont empilables. Tous les produits sont également disponibles avec un coussin en polyuréthane intégrale ou rembourré.



Koki Wire



Koki Wire

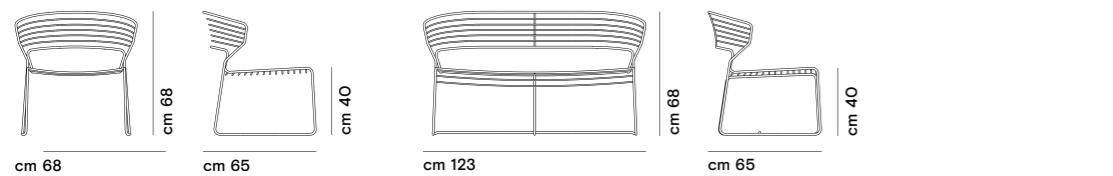
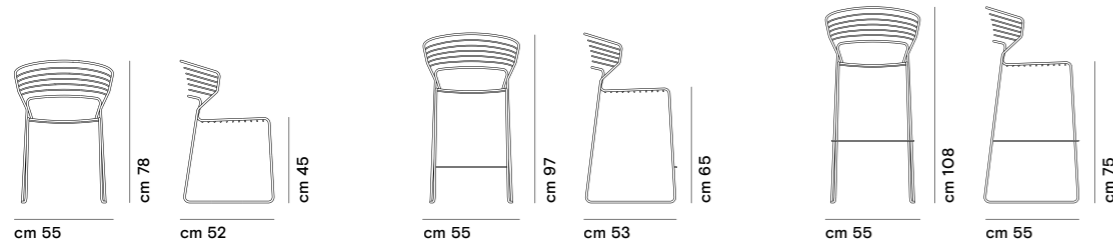

## Koki Wire — cuoio

design Pocci + Dondoli  
2022

Sedia con struttura in tondino di acciaio verniciato o nelle esclusive finiture Desalto. Seduta in cuoio pieno fiore teso sulla struttura. Il rivestimento in cuoio non è removibile e destinato al solo uso interno.

Stuhl mit Struktur aus lackiertem Stahlrohr oder in den Desalto exklusiven Ausführungen. Sitz aus vollnarbigem Kernleder, das über die Struktur gespannt ist. Der Lederbezug ist nicht abnehmbar und er ist geeignet nur für den Innenbereich.

Silla con estructura en tubo de acero lacado o en los acabados exclusivos Desalto. Asiento en cuero plena flor tensado sobre la estructura. La tapicería de cuero no es removible y es utilizable solo para uso interno.

Chair with structure in lacquered steel rod or in the Desalto exclusive finishes. Seat in full grain cowhide stretched over the structure. The cowhide upholstery is not removable and is intended for internal use only.

Chaise avec structure en tube d'acier laqué ou dans les finitions exclusives Desalto. Assise en cuir sellier pleine fleur tendu sur la structure. Le revêtement en cuir sellier n'est pas amovible et est destiné à un usage à l'intérieur uniquement.



dettaglio / detail



Koki Wire — cuoio

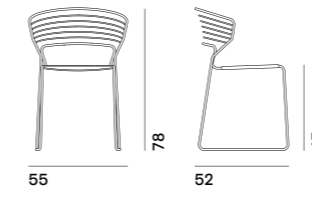



## Lisbona

design Pocchi + Dondoli  
2009

Sedia non impilabile, con rivestimento cucito a mano in cuoio, cuoietto, pelle ed ecopelle, e struttura in polipropilene caricato con fibra di vetro.

Stuhl mit Bezug aus handgenähtem Kernleder, Cuoietto, Leder und Kunstleder, Gestell aus glasfaserverstärktem Polypropylen. Nicht stapelbar.

Silla no apilable, con funda en cuero, cuoietto, piel y piel ecológica, cosido a mano, con estructura en polipropileno cargado con fibra de vidrio.

Not stackable chair, with hand-sewed covering in cow hide, cuoietto, leather and ecoleather, and structure of polypropylene reinforced with fibre glass.

Chaise non empilable, avec revêtement cousu à la main en cuir sellier, cuoietto, cuir souple et simili-cuir, avec structure en polypropylène chargé de fibre de verre.



Lisbona

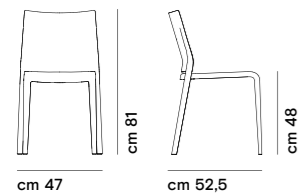

## Mun

design Mario Ferrarini  
2019

Sedia con struttura in tubolare di acciaio Ø 30 mm. Seduta imbottita e rivestita in tessuto, pelle o ecopelle.

Stuhl mit Gestell aus Stahlrohr Ø 30 mm. Polstersitz bezogen aus Stoff, Leder oder Artleder.

Silla con estructura en tubo de acero diámetro 30 mm. Asiento alcohado y revestido en tejido, piel o piel ecológica.

Chair with tubular steel frame Ø 30 mm. Upholstered seat covered with fabric, leather or ecoleather.

Chaise avec structure en tubulaire d'acier diamètre 30 mm. Assise rembourrée et revêtue en tissu, cuir ou simili cuir.



Mun

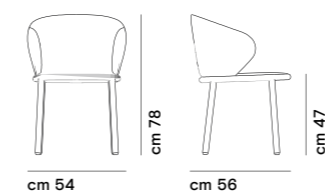

## Myg

design Mario Ferrarini  
2018

Sgabello in tre altezze,  
H 80/64/47 cm, impilabile. Seduta  
in poliuretano integrale, struttura in  
tubolare di acciaio a sezione ovale,  
poggiapiedi in acciaio inox satinato.

Barhocker in drei Höhen  
H 80/64/47 cm stapelbar.  
Sitz aus integralem Polyurethan,  
Rohrstahlgestell mit ovalem  
Abschnitt, Fußstutz aus satiniertem  
Edelstahl.

Taburete en tres alturas,  
H 80/64/47 cm, apilable. Asiento en  
poliuretano integral, estructura en  
tubo de acero de sección ovalada,  
reposapiés en acero inox cepillado.

Barstool in three heights,  
H 80/64/47 cm, stackable. Seat in  
integral polyurethane, tubular steel  
frame with oval shape, footrest in  
matte stainless steel.

Tabouret en 3 hauteurs,  
H 80/64/47 cm, empilable. Assise  
en mousse de polyuréthane intégral  
et structure en tubulaire d'acier à  
section ovale, repose-pied en acier  
inox satiné.



Myg

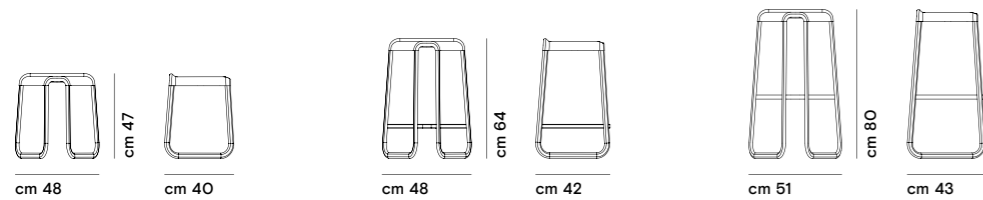

## Nara

design Piergiorgio Cazzaniga  
2014

Sedia imbottita in tessuto  
sfoderabile, pelle o ecopelle.  
Scocca in poliuretano flessibile  
con cinghie elastiche inserite  
nella seduta. Gambe in  
pressofusione di alluminio.

Gepolsterter Stuhl aus Stoff  
(abnehmbar), Leder oder  
Kunstleder. Sitzschale aus  
Polyurethan mit elastischer  
Gurtung. Beine aus  
Aluminiumdruckguss.

Silla acolchada en tejido  
desenfundable, piel o piel  
ecológica. Casco e poliuretano  
flexible con cinchas elásticas  
introducidas en el asiento.  
Patas en fusión de aluminio.

Upholstered chair with removable  
fabric, leather or eco-leather.  
Seat and back in flexible  
polyurethane with seat elastic belt.  
Die-cast aluminium legs.

Chaise rembourrée en tissu  
déhoussable, cuir souple ou simili  
cuir. Coque en polyuréthane flexible  
avec sangles élastiques insérées  
dans l'assise. Pieds moulés sous  
pression.



Nara

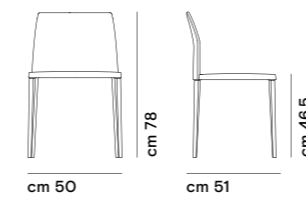

## Paper

design Cristian Gori  
2018

Seduta in polipropilene caricato a fibra di vetro, disponibile nelle versioni: 4 gambe in tubo di acciaio a sezione ellittica; massello di rovere; piantana centrale girevole con base a 4 razze; piantana centrale girevole ad altezza variabile con base a 5 razze dotate di ruote; 4 gambe in tubolare di acciaio tondo (adatta per l'utilizzo outdoor).

Sitz aus Glasfaserverstärktem Polypropylen, verfügbar in den folgenden Versionen: 4 elliptische Beine aus Stahlrohr; aus Eiche Massivholz; Drehbarer Mittelständer mit 4 Kreuzfüsse; Drehbarer Mittelständer höhenverstellbar mit 5 Kreuzfüsse ausgestattet mit Rollen; 4 Beine aus rundem Stahlrohr (geeignet für Aussenbereich);

Casco en polipropileno cargado con fibra de vidrio, disponible en les versiones: estructura de 4 patas en tubo de acero con sección elíptica; en roble macizo; base central giratoria con 4 radios; base central giratoria con altura variable y 5 radios con ruedas; 4 patas en tubo de acero redondo (utilizable también para uso externo).

Seat in polypropylene reinforced with fibre glass, available in the following versions: 4 steel tube elliptical legs; with solid oak wood; swivelling central upright with 4 star base; swivelling central upright adjustable height with 5 star base with wheels; 4 legs with round tubular steel (available for outdoor).

Assise en polypropylène chargé de fibre de verre, disponible dans les versions: structure 4 pieds en tube d'acier à section elliptique; en chêne massif; piètement centrale pivotant à 4 branches; piètement centrale pivotant à hauteur variable avec base à 5 branches sur roulettes; 4 pieds en tubulaire d'acier à section ronde (apte aussi pour outdoor);



Paper

Paper outdoor



Paper

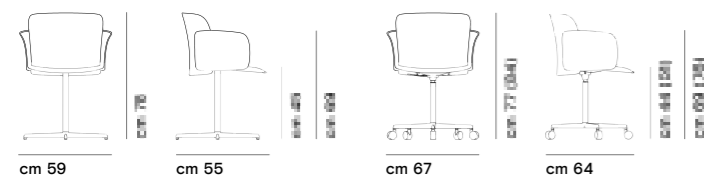
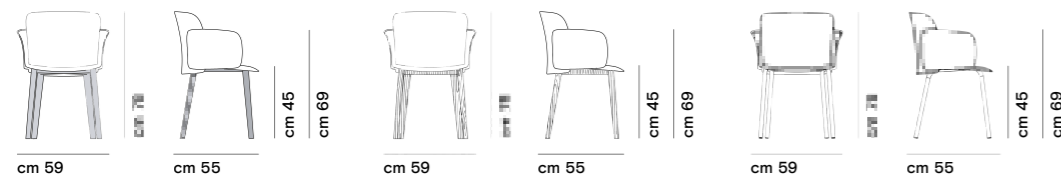

## Ply

design Pocci + Dondoli  
2017

Sedia impilabile con struttura in acciaio. Sedile e schienale in polipropilene caricato con fibra di vetro, disponibili anche rivestiti in cuoio e cuoietto. Il polipropilene è stabilizzato anti UV. Gambe in acciaio conificato a sezione triangolare. Disponibile anche versione sgabello con e senza braccioli.

Stapelbarer Stuhl mit Stahlgestell. Sitz und Rückenlehne aus Glasfaserverstärktem Polypropylen, verfügbar auch bezogen mit Kernleder und Cuoietto. Das Polypropylen ist UV-Strahlen geschützt. Beine aus konischem Stahl mit dreieckigem Abschnitt. Verfügar auch als Hocker, mit und ohne Armlehnen.

Silla apilable con estructura de acero. Asiento y respaldo en polipropileno cargado con fibra de vidrio, también disponible tapizados en cuero y cuoietto. El polipropileno está estabilizado anti-UV. Patas de acero cónico con sección triangular. También disponible la versión de taburete con y sin brazos.

Stackable chair with steel frame. Seat and back in polypropylene reinforced with glass fibre, available also covered with cow-hide and cuoietto. The polypropylene is stabilised anti-UV. Steel legs in conic shape, with triangular section. Also available as a stool with and without armrests.

Chaise empilable avec structure en acier. Assise et dossier en polypropylène chargé de fibre de verre, disponibles aussi revêtus en cuir sellier et cuoietto. Le polypropylène est stabilisé anti-UV. Pieds en acier conique à section triangulaire. Disponible aussi en version tabouret avec ou sans accoudoirs.



Ply

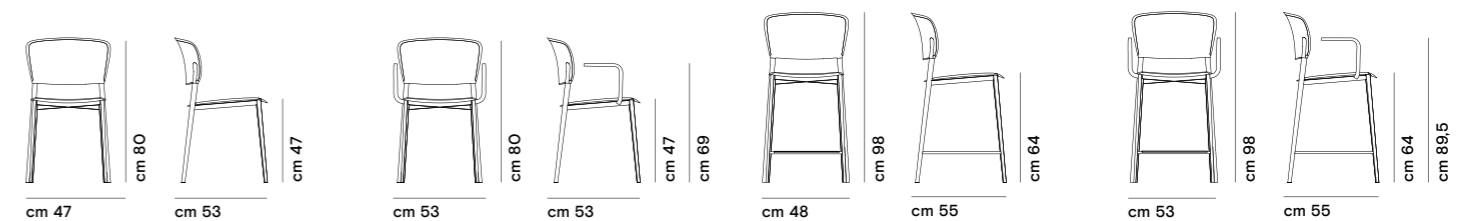

## Riga

design Pocci + Dondoli  
2008

Sedia impilabile in polipropilene caricato con fibra di vetro stabilizzato anti UV, stampata con tecnologia air moulding, adatta anche per uso esterno.

Stapelbarer Stuhl aus UV-resistentem, glasfaserverstärktem Polypropylen, Pressgussverfahren mit "air-moulding"-Technologie, auch für Outdoor geeignet.

Silla apilable en polipropileno cargado con fibra de vidrio estabilizado anti UV, moldeada con tecnología air moulding, adapta también para el uso exterior.

Stacking chair made of polypropylene reinforced with anti-UV stabilized fibreglass, realized with air moulding technology, suitable for outdoor use.

Chaise empilable en polypropylène chargé avec fibre de verre stabilisé anti UV, moulée avec technologie air moulding, adapte également pour utilisation à l'extérieur.



Riga

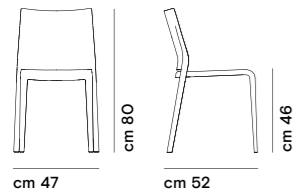

cm 47

cm 52

cm 80

cm 46

## Sand

design Pocci + Dondoli  
2002

Sedia impilabile con o senza braccioli, struttura in alluminio pressofuso. Seduta e schienale in polipropilene caricato con fibra di vetro, stabilizzato anti UV. Versioni laccate con polipropilene utilizzabili anche per uso esterno. Disponibile anche nelle versioni rivestite in tessuto, pelle, ecopelle e cuoio. Lo sgabello (non impilabile) ha le stesse caratteristiche della sedia.

Stapelbarer Stuhl mit oder ohne Armlehnen, Gestell aus Aluminiumdruckguss. Sitz und Rücklehne aus UV-resistentem, glasfaserverstärktem Polypropylen. Lackierte Fussgestelle mit Polypropylen auch für Outdoor. Auch verfügbar mit Bezug aus Gewebe, Leder, Kunstleder und Kernleder. Der Hocker (nicht stapelbar), hat die gleichen Eigenschaften des Stuhls.

Silla apilable con y sin brazos, estructura en presofusión de aluminio. Asiento y respaldo de polipropileno reforzado con fibra de vidrio, estabilizado anti UV. Versiones lacadas con polipropileno útiles también para el exterior. Disponible en versión revestida en tejido, cuero, piel y piel ecológica. El taburete (no apilable) tiene las mismas características que la silla.

Stacking chair with or without armrests, die-cast aluminium frame. Seat and back of polypropylene, reinforced with fiber glass, stabilised anti-UV. Lacquered frame versions with polypropylene suitable also for outdoor use. Available also with fabric, leather, eco-leather and cow-hide covering. The stool (not stackable) has the same characteristics as the chair.

Chaise empilable avec ou sans accoudoirs, structure en aluminium moulé sous pression. Assise et dossier en polypropylène chargé en verre stabilisé anti UV. Versions avec structure laquée et polypropylène utilisables à l'extérieur. Disponible en versions revêtue de tissu, cuir souple, simili-cuir et cuir sellier. Le tabouret (non empilable) a les mêmes caractéristiques que la chaise.



Sand

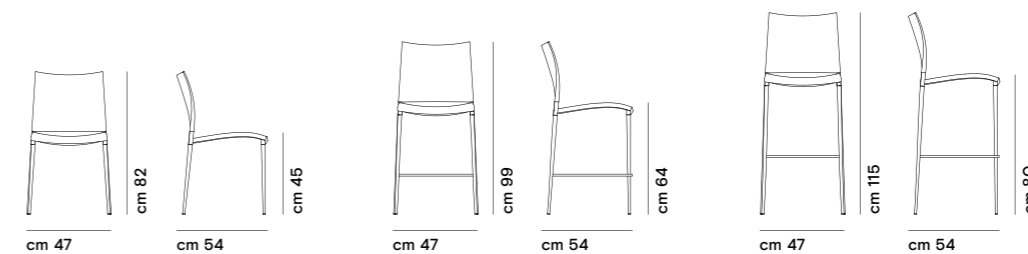

cm 47

cm 82

cm 54

cm 45

cm 47

cm 99

cm 54

cm 64

cm 47

cm 115

cm 54

cm 80



dettaglio / detail

## Sand Air

design Pocci + Dondoli  
2003

Sedia impilabile con o senza braccioli, struttura in alluminio pressofuso. Seduta e schienale foderati con rete in filo di poliestere rivestito in PVC (Sand Air) e PVC + canapa (Sand Air Canatex / Duo) in vari colori. Versioni laccate utilizzabili anche per uso esterno. Lo sgabello (non impilabile) ha le stesse caratteristiche della sedia.

Stapelbarer Stuhl mit oder ohne Armlehnen, Gestell aus Aluminiumdruckguss. Sitz und Rücklehne aus Polyesternetz (Sand Air) und PVC/Hanf bezogen (Sand Air Canatex / Duo) in verschiedenen Farben. Lackierte Gestelle auch für Outdoor geeignet. Der Hocker (nicht stapelbar) hat die gleichen Eigenschaften des Stuhls.

Silla apilable con o sin brazos, estructura en presofusión de aluminio. Asiento y respaldo en red de poliéster revestido en PVC (Sand Air) y PVC + cañamo (Sand Air Canatex / Duo) en diferentes colores. Versiones lacadas utilizables también por el exterior. El taburete (no apilable) tiene las mismas características que la silla.

Stacking chair with or without armrests, die-cast aluminium frame. Seat and back in mesh made of polyester thread covered with PVC (Sand Air) and PVC + hemp (Sand Air Canatex / Duo) in different colours. Lacquered frame versions also available for outdoor use. The barstool (not stackable) has the same characteristics as the chair.

Chaise empilable avec ou sans accoudoirs, structure en aluminium moulé sous pression. Assise et dossier en maille de polyester revêtu de PVC (Sand Air) et PVC + chanvre (Sand Air Canatex / Duo) dans différentes couleurs. Versions avec structure laquée utilisables également à l'extérieur. Le tabouret (non empilable) a les mêmes caractéristiques que la chaise.



Sand Air



dettaglio / detail

## Sand Light

design Pocci + Dondoli  
2010

Sedia impilabile con e senza braccioli in pressofusione di alluminio. Seduta e schienale foderati con rete in filo di poliestere rivestito in PVC (Sand Air) e PVC + canapa (Sand Air Canatex / Duo) in vari colori. Disponibile nelle versioni indoor e outdoor.

Stapelbarer Stuhl mit oder ohne Armlehnen, Gestell aus Aluminiumdruckguss. Sitz und Rücklehne aus Polyesternetz mit PVC (Sand Air) und PVC/Hanf bezogen (Sand Air Canatex / Duo) in verschiedenen Farben. Verfügbar für In- und Outdoor.

Silla apilable con o sin brazos, estructura en presofusión de aluminio. Asiento y respaldo en red de poliéster revestido en PVC (Sand Air) y PVC + cañamo (Sand Air Canatex / Duo) en diferentes colores. Disponible en las versiones de interior y de exterior.

Stacking chair with or without armrests, die-cast aluminium frame. Seat and back with mesh made of polyester thread covered in PVC (Sand Air) and PVC + hemp (Sand Air Canatex / Duo) in different colours. Available in indoor and outdoor versions.

Chaise empilable avec ou sans accoudoirs, structure en aluminium moulé sous pression. Assise et dossier en maille de polyester revêtu de PVC (Sand Air) et PVC + chanvre (Sand Air Canatex / Duo) dans différentes couleurs. Disponible dans les versions pour intérieur et extérieur.



Sand Light



dettaglio / detail

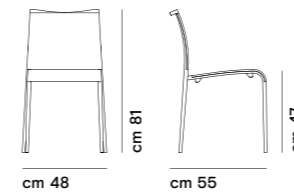
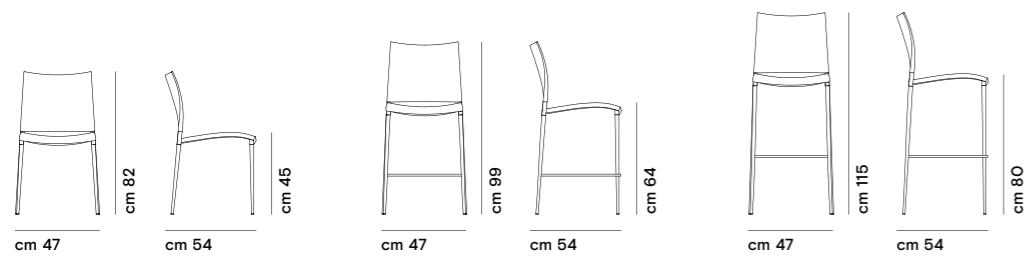

## Softer than Steel

design Nendo  
2014

Sedia con struttura in tubo di acciaio e seduta in lamiera di acciaio. Disponibile nelle versioni indoor e outdoor.

Stuhl mit Gestell aus Stahlrohr und Sitz aus Stahlblech. Verfügbar für In- und Outdoor.

Silla con estructura en tubo de acero y asiento en chapa de acero. Disponible en las versiones de interior y de exterior.

Chair with tubular steel frame and seat made of aluminium plate. Available in indoor and outdoor versions.

Chaise avec structure en tube d'acier et assise en acier. Disponible dans les versions pour intérieur et extérieur.

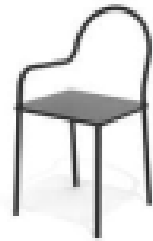

Softer than Steel



dettaglio / detail

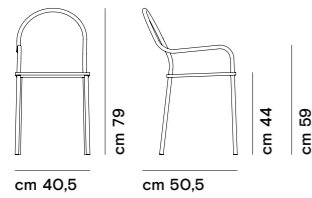

## Softer than Steel

design Nendo  
2014

Panca in lamiera con schienale curvato e gambe in tondino di acciaio laccato. Disponibile anche in versione Outdoor.

Hocker-Bank mit gebogener Rückenlehne und Beinen aus lackiertem Rundstahl.

Banco en chapa de metal con respaldo curvado y patas en tubo de acero lacado. Disponible en las versiones de interior y de exterior.

Bench in metal sheet with bent back and lacquered steel rod legs. Also available in outdoor version.

Banc en métal avec dossier courbé et pieds en tube d'acier laqué. Disponible dans les versions pour intérieur et extérieur.



Softer than Steel

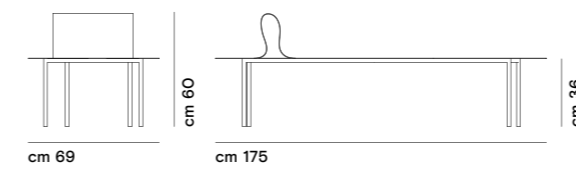
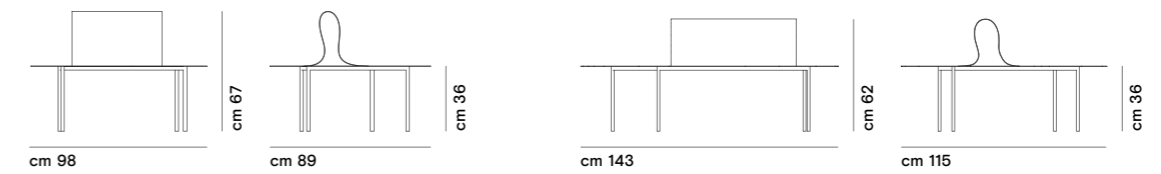

## Strong Special

design Eugeni Quitllet  
2022

Famiglia di sedute, poltrona e divanetto, con struttura in tubolare di acciaio curvato Ø 50 mm. Seduta e schienale imbottiti in poliuretano con struttura interna in acciaio e rivestiti in tessuto. Tavolino con struttura in tubolare di acciaio curvato Ø 50 mm laccato, piano in MDF rivestito tramite spatolatura manuale.

Sitzfamilie, Sessel und Sofa, mit Struktur aus gebogenem Stahlrohr Ø 50 mm. Sitz und Rückenlehne mit Polyurethan gepolstert, mit interner Stahlstruktur und mit Stoff bezogen. Couchtisch mit gestell aus stahlrohr Ø 50 mm lackiert, Platte aus MDF hand-bezogen.

Familia de asientos, sillón y sofá, con estructura en tubular de acero curvado Ø 50 mm. Asiento y respaldo tapizado en poliuretano con estructura interna de acero y tapizado en tejido. Mesitas con estructura en tubo de acero curvado Ø 50 mm lacado, encimera en MDF revestido gracias a una aplicación manual con espátula.

Family of seats, armchair and sofa, with structure in curved tubular steel Ø 50 mm. Seat and back upholstered in polyurethane with internal steel structure and covered in fabric. Low table with frame in folded lacquered tubular steel Ø 50 mm, top in MDF covered thanks to a manual broad knife application.

Famille d'assises, fauteuil et canapé, avec structure en tube d'acier courbé Ø 50 mm. Assise et dossier rembourrés en polyuréthane avec structure interne en acier et revêtements en tissu. Table basse avec structure en tubulaire d'acier courbé Ø 50 mm laqué, plateau revêtu à main à l'aide d'une spatule.



Strong Special



dettaglio / detail

## Strong

design Eugeni Quitllet  
2019

Sedia con struttura in tubolare di acciaio curvato Ø 35 mm. Seduta imbottita e rivestita in tessuto, pelle o ecopelle.

Stuhl mit Gestell aus gebogenem Stahlrohr Ø 35 mm. Polstersitz bezogen aus Stoff, Leder oder Artleder.

Silla con estructura en tubo de acero curvado diámetro 35 mm. Asiento alcohado y revestido en tejido, piel o piel ecológica.

Chair with frame in folded tubular steel Ø 35 mm. Upholstered chair covered with fabric, leather or ecoleather.

Chaise avec structure en tubulaire d'acier courbée diamètre 35 mm. Assise rembourrée et revêtue en tissu, cuir ou simili cuir.



Strong

Armstrong



dettaglio / detail

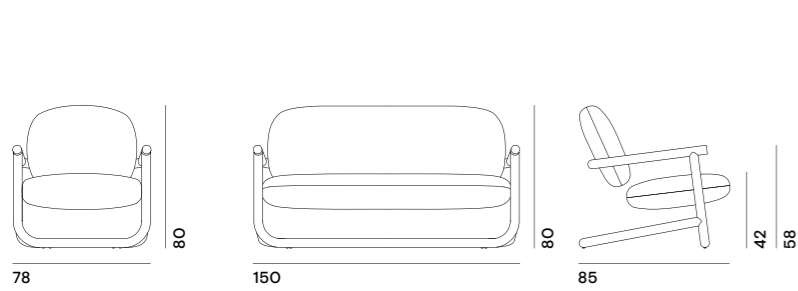

poltrona / armchair

divanetto / sofa

tavolino / low table

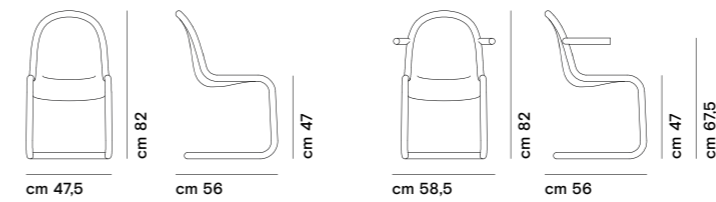

## Strong

design Eugeni Quitllet  
2019

Sgabello con struttura in tubo di acciaio Ø 60 mm. Sedile in lamiera o legno. Disponibile nelle versioni indoor e outdoor.

Hocker mit Gestell aus Stahlrohr Ø 60 mm. Sitz in Blech oder Holz. Verfügbar für In- und Outdoor.

Taburete con estructura en tubo de acero diámetro 60 mm. Asiento en chapa o madera. Disponible en las versiones de interior y de exterior.

Stool with tubular steel frame Ø 60 mm. Seat in sheet metal or wood. Available in indoor and outdoor versions.

Tabouret avec structure en tube d'acier diamètre 60 mm. Assise en tôle ou bois. Disponible dans les versions pour intérieur et extérieur.



Strong



dettaglio / detail

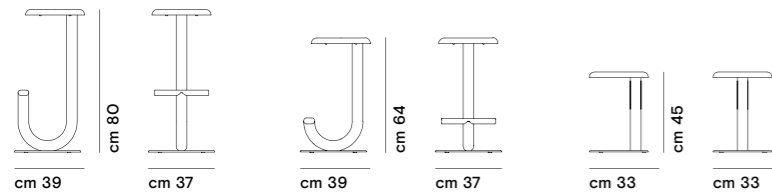

## Trace

design Shin Azumi  
2005

Sedia impilabile con scocca in tecnopolimero plastico composito a densità variabile. Struttura in acciaio inox spazzolato (adatta anche per uso esterno) cromata o laccata. Versione girevole con base a quattro razze in alluminio pressofuso e tubo in acciaio. Versione con cuscino in eco-pelle non impilabile.

Stapelbarer Stuhl mit Sitzschale aus Technopolymer (verschiedenen Schichten mit unterschiedlicher Dichte). Gestell aus gebürstetem Edelstahl (auch für den Aussenbereich geeignet) lackiert oder verchromt. Drehbares Gestell mit Sternfuss in Aludruckguss und Rohr aus Stahl. Version mit Sitzkissen aus Kunstleder nicht stapelbar.

Silla apilable con casco en tecnopolímero plástico compuesto de densidad variable. Estructura en acero inox cepillado (adapta también para el uso en el exterior) lacado o cromo. Versión giratoria con base con 4 radios en fusión de aluminio y tubo en acero. Versión con cojín en piel ecológica no apilable.

Stackable chair with variable density compound engineering polymer body. Brushed stainless steel (also suitable for outdoor use) lacquered or chromed structure. Swivelling version with cross-shaped base in die-cast aluminium and steel tube. Version with cushion in eco-leather not stackable.

Chaise empilable avec coque en technopolymère plastique composite à densité variable. Structure en acier inox brossé (idéale également pour utilisation à l'extérieur) laquée ou chromée. Version pivotante avec piétement à quatre bras en aluminium moulé sous pression et tube en acier. Version avec coussin en peau écologique pas empilable.



Trace

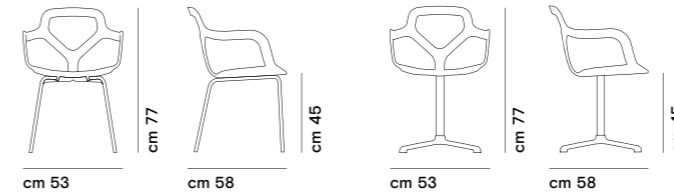



## Void

design Guglielmo Poletti  
2019

Sgabello realizzato in lamiera di acciaio spessore 3 mm.  
Panca realizzata in lamiera di acciaio spessore 3 mm.

Hocker aus Stahlblech Stärke 3 mm.  
Bank aus Stahlblech Stärke 3 mm.

Taburete realizado en chapa de acero espesor 3 mm.  
Banco realizado en chapa de acero espesor 3 mm.

Stool in sheet steel 3 mm thickness.  
Bench in sheet steel 3 mm thickness.

Tabouret avec feuille d'acier épaisseur 3 mm. Banc avec feuille d'acier épaisseur 3 mm.



Void

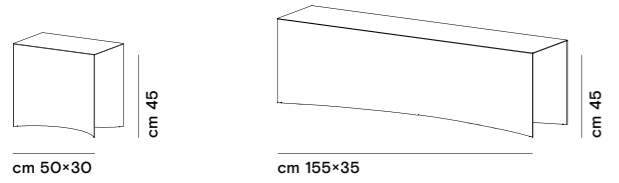

sgabello / stool

panca / bench

## Wok

design Pocci + Dondoli  
2005

Sgabello con scocca in acrilico, disponibile anche con seduta rivestita in ecopelle, pelle, cuoio o tessuto. Struttura girevole ad altezza variabile in alluminio pressofuso e tubo in acciaio. La base a crociera è dotata di rotelle sferiche a scomparsa che si bloccano col peso della persona.

Barhocker mit Schalensitz aus Acryl oder bezogen mit Stoff, Kunstleder, Leder und Kernleder. Drehbares Gestell (höhenverstellbar) aus Aluminiumdruckguss und Stahlrohr. Kreuzbasis mit Kugelrollen, die bei Nutzung blockieren.

Taburete con casco en acrílico disponible también en la versión tapizada en tejido, piel ecológica, piel o cuero. Estructura giratoria a altura variable en presofusión de aluminio y tubo de acero. Base cruzada dotada de ruedas esféricas escondidas que se bloquean con el peso de la persona.

Barstool with acrylic body, also available with fabric, eco-leather, leather and cow-hide covering. Swivelling structure with variable height, made of die-cast aluminium and steel tube. Cross base provided with spherical retractable castors, self-locking thanks to the weight of the user.

Tabouret avec coque en acrylique, disponible aussi revêtue de tissu, simili cuir, cuir souple ou cuir sellier. Structure pivotante à hauteur variable en aluminium moulé sous pression et tube en acier. Base croisée dotée de roulettes sphériques escamotables autobloquantes avec le poids de l'utilisateur.



Wok

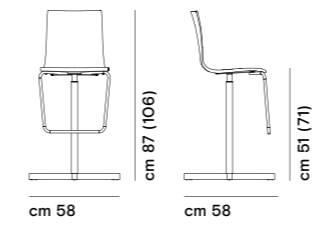

## Element

design Tokujin Yoshioka  
2013

Tavolino e console smontabile con struttura in acciaio, piani in MDF, nelle finiture laccate o materiche spatolate a mano.

Tischchen und Konsole mit Stahlgestell, Platten aus MDF, mit lackierter Ausführung oder manuell gespachtelter Oberfläche.

Mesita y consola desmontable con estructura de acero, encimeras en MDF, en acabado lacado o matérico espatulado a mano.

Disassembling small table and console with steel structure, tops in MDF, in lacquered finishing or covered with hand-spread materic finishes.

Table basse et console décomposable avec structure en acier, plateaux en MDF, dans les finitions laquées ou matériaux spatulées à la main.



Element

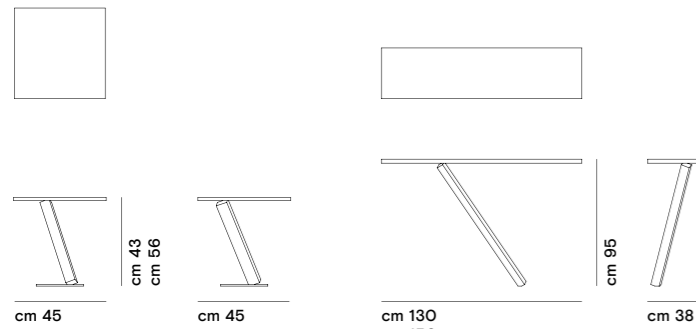

tavolino / small table

console

## Helsinki 15

design Caronni + Bonanomi  
2014

Sistema di tavolini e console con struttura smontabile in acciaio sezione 15×15 mm, giunti in pressofusione. Struttura nelle finiture laccato opaco oppure nelle finiture esclusive Desalto. Piani in cristallo, legno o ceramica.

System von Tischchen und Konsolen mit Stahlgestell, Querschnitt 15×15 mm und Verbindungselementen aus Druckguss. Gestell in den matt lackierten Ausführungen oder in den exklusiven Desalto Ausführungen. Platten aus Glas, Holztisch oder Keramik.

Sistema de mesitas y consolas con estructura desmontable en acero, sección 15×15 mm y juntas en presofusión. Estructura en acabado mate lacados o en los exclusivos acabados Desalto. Encimeras en cristal, madera o cerámica.

Range of small tables and console with disassembling steel frame, 15×15 mm section, and die-cast aluminium joints. Frame in matt lacquered finishing or in Desalto's exclusive finishes. Glass, wood or ceramic tops.

Système de tables basses et consoles avec structure démontable en acier, section 15×15 mm, et joints moulés sous pression. Structure dans les finitions mates laquées ou dans les finitions exclusives Desalto. Plateaux en verre, en bois ou céramique.

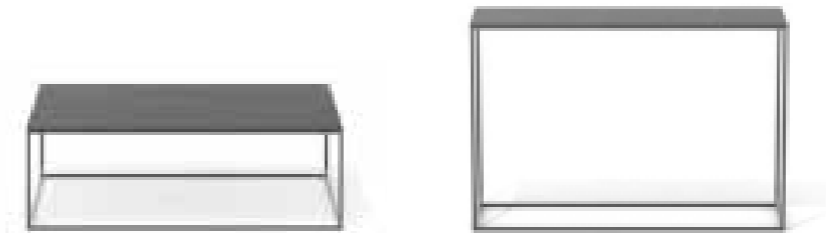

Helsinki 15

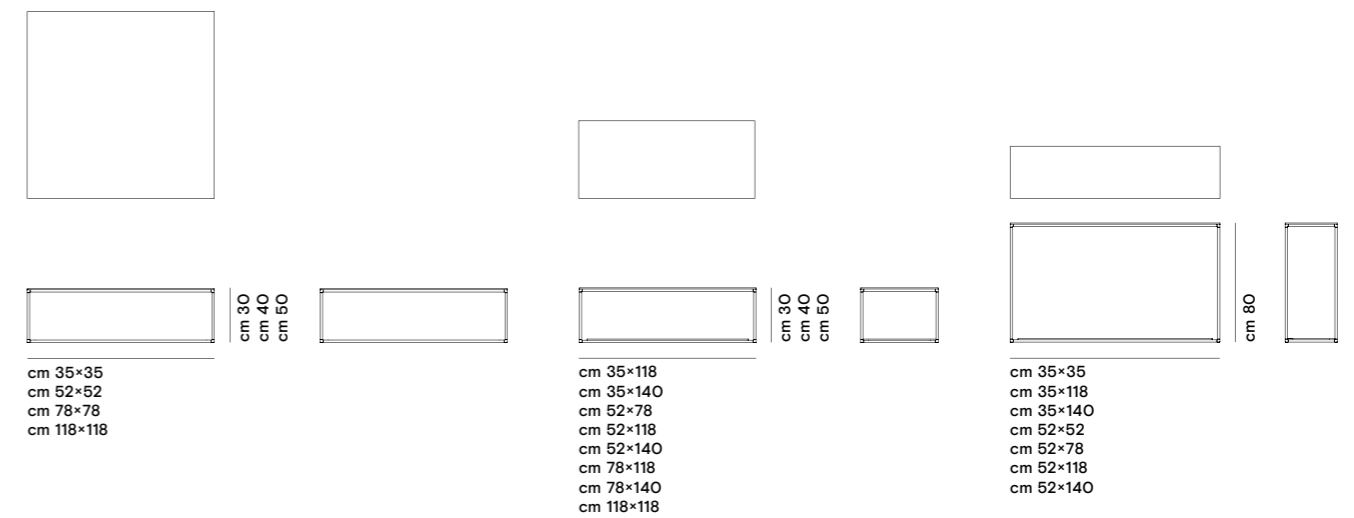

tavolino / small table

console

## Helsinki 30

design Caronni + Bonanomi  
1995

Sistema di tavoli con struttura smontabile in acciaio sezione 30×30 mm e giunti in pressofusione. Struttura nelle finiture laccato opaco oppure nelle finiture esclusive Desalto. Piani in cristallo, laminato Fenix®, laminato stratificato, ceramica o essenza.

Tischsystem mit Stahlgestell, Querschnitt 30×30 mm, Verbindungselemente aus Druckguss. Gestell in den matt lackierten Ausführungen oder in den exklusiven Desalto Ausführungen. Platten aus Glas, Fenix® Laminat, Schichtlaminat, Keramik oder Holz.

Sistema de mesas con estructura desmontable en acero, sección 30×30 mm y juntas en presofusión. Estructura en los acabados lacados mate o en los exclusivos acabados Desalto. Encimeras en cristal, laminado Fenix®, laminado estratificado, cerámica o madera.

Range of tables with disassembling steel frame, section 30×30 mm, and die-cast aluminium joints. Frame in the matt lacquered finishing or in the Desalto's exclusive finishes. Tops available in Glass, Fenix® laminate, layered laminate, ceramic or wooden tops.

Système de tables avec structure démontable en acier, section 30×30 mm, et joints moulés sous pression. Structure dans les finitions mates laquées ou dans les exclusives finitions Desalto. Plateaux en verre, laminé Fenix®, laminé stratifié, céramique ou en bois.



Helsinki 30

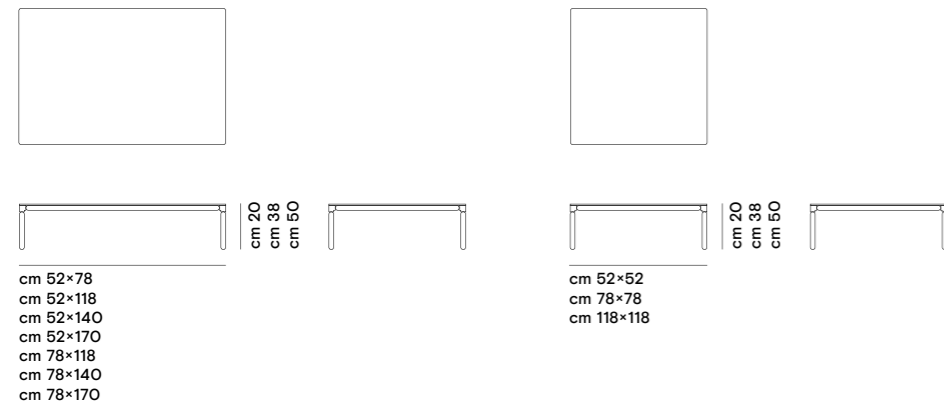

## Hexagon

design Tokujin Yoshioka  
2013

Tavolino con struttura smontabile in acciaio, colonnine in acciaio di sezione esagonale, piani in cristallo molato o ceramica. Disponibile anche nella versione impilabile con piano in cristallo molato, ceramica o in lamiera.

Tischchen mit Stahlgestell, Beine aus Stahl mit hexagonalem Schnitt und geschliffener Glasplatte oder aus Keramik. Stapelbaren Version mit Platte aus geschliffenem Glas, Keramik oder aus Metal.

Mesita con estructura desmontable en acero, columnas verticales con sección hexagonal en acero, sobres en cristal biselado o en cerámica. Disponible también en la versión apilable con sobre en cristal biselado, cerámica o en metal.

Small table with disassembling steel frame, hexagonal shaped frame, tops in bevelled glass or ceramic. Available also in the nest-inside version with bevelled glass, ceramic or metal sheet top.

Table basse avec structure démontable en acier, petites colonnes en acier avec section hexagonale, plateaux en verre biseauté ou en céramique. Disponible aussi dans la version empilable avec plateau en verre biseauté, en céramique ou en métal.

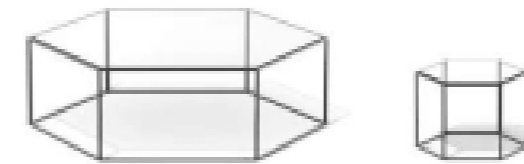

Hexagon

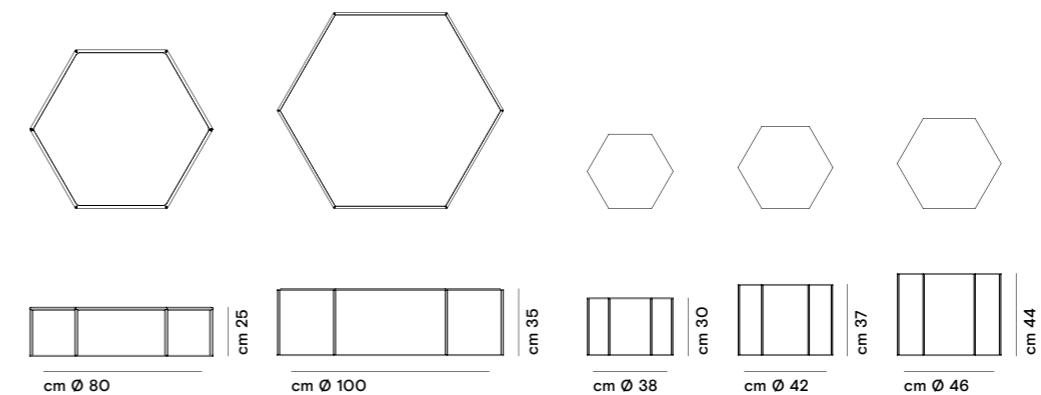

## Icaro O15

design Caronni + Bonanomi  
2015

Tavolino e console fissata a muro con struttura e cassetti in acciaio, piani in cristallo temperato da 8 mm oppure in ceramica da 6 mm. Cassetti montati su guide a sfera a estrazione totale. Portaoggetti per interno cassetti in neoprene lavabile di colore nero (optional). Per il tavolino è disponibile una piattina di raccordo in acciaio nella stessa finitura della struttura.

Couchtische und Wandkonsole mit Gestell und Schubladen aus Stahl in den Ausführungen, temperierte Glasplatten 8 mm oder aus Keramik 6 mm. Schubladen mit Vollauszug. Optional Schubladeneinsätze aus schwarzem Neopren. Nur aus ästhetischen Gründen für den Couchtisch verfügbar: ein Befestigungselement aus Stahl in der gleichen Ausführung des Gestells.

Mesitas y consola a la pared con estructura y cajones en acero, sobres en cristal templado 8 mm o en cerámica 6 mm. Cajones montados sobre guías esféricas de extracción total. Porta-objetos internos para cajones en neopreno lavable en color negro (opcional). Para la mesa baja y sólo con fines estéticos, hay disponible una pieza de unión en acero del mismo acabado que la estructura.

Small tables and wall console with steel frame and drawers, tops in toughened glass 8 mm or ceramic 6 mm. Drawers on full extension ball bearing slides. Drawers storage accessories in washable black neoprene (optional). Just for aesthetic purposes for the small table, it is available a connection bracket made of steel, with the same finishing as the frame.

Tables basses et console au mur avec structure et tiroirs en acier, plateaux en verre trempé 8 mm ou en céramique 6 mm. Tiroirs montés sur charnières coulissantes à roulement à extraction totale. Porte-objets pour l'intérieur des tiroirs en néoprène lavable, en couleur noir (en option). Seulement à but esthétique pour la table basse, les pieds sont disponibles avec une platine de liaison en acier dans la même finition que la structure.

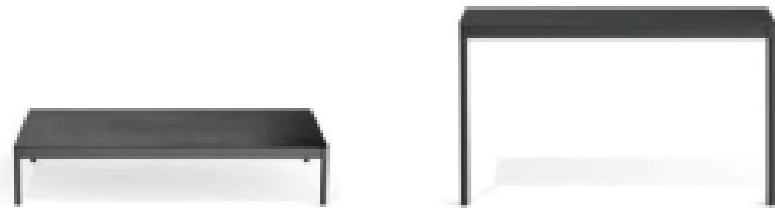

Icaro O15

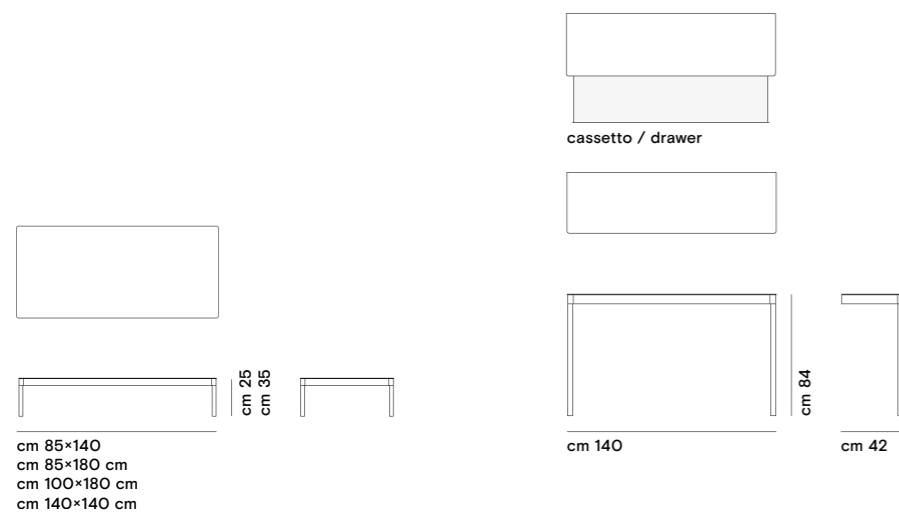

tavolino / small table

console

## L45

design Guglielmo Poletti  
2020

Tavolino con gambe in angolare di acciaio con spessore di 6 mm lavorate a controllo numerico; telaio in angolare di acciaio con spessore di 5 mm lavorato a controllo numerico. Top in legno, poliestere o spatolato cemento.

Eckige Stahlbeine, Materialstärke 6 mm, mit Steuerungsprogramm bearbeitet, Rahmen aus Stahlwinkeln Materialstärke 5 mm, ebenfalls mit Steuerungsprogramm bearbeitet. Platte aus Holz furniert, Polyester oder mit Zement bezogen.

Patas angulares en acero de 6 mm, moldeadas con máquina de control numérico, estructura también en acero con espesor 5 mm, y moldeada con máquina de control numérico. Top en madera, en poliéstero o en cemento aplicado a mano con espátula.

Tables and small tables collection with angular steel legs, 6 mm thickness, CNC-machined. Frame in angular steel with 5 mm thickness, CNC-machined. Honeycomb top with solid wood, polyester finish or hand-spread concrete finishes.

Pieds angulaires en acier, 6 mm travaillé avec machine à contrôle numérique, cadre angulaire en acier 5 mm d'épaisseur travaillé avec machine à contrôle numérique. Plateau en bois, en polyester ou recouvert de ciment étalé à la main.



L45

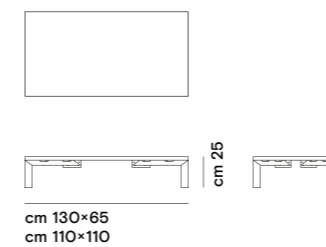

## Liko Glass

design Arik Levy  
2004

Tavolino smontabile con piano in cristallo temperato e gambe in acciaio.

Tischchen mit temperierter Glasplatte und Beinen aus Stahl.

Mesita desmontable con encimera en cristal templado y patas en acero.

Disassembling small table with toughened glass top and steel legs.

Table basse démontable avec plateau en verre trempé et pieds en acier.



Liko Glass



cm 99×99  
cm 79×119  
cm 79×150  
cm 90×190  
cm 90×220

cm 35

## Mini Clay

design Marc Krusin  
2016

Tavolino smontabile con base in poliuretano rigido realizzato nelle finiture laccate o materiche spatolate a mano riportate a listino. Top in ceramica, MDF laccato o nelle finiture materiche spatolate a mano. Disponibile nelle versioni indoor e outdoor.

Tischchen mit Basis aus hartem Polyurethan mit lackierter oder manuell gespachtelter Oberfläche, Ausführungen laut Preisliste. Platten aus den Ausführungen Keramik, MDF lackiert oder gespachtelt. Verfügbar für In- und Outdoor.

Mesita desmontable con base en poliuretano rígido en acabado lacado o matérico espatulado a mano como indicado en la lista de precios. Encimera en los acabados cerámica, MDF lacado o matérico espatulado. Disponible en las versiones de interior y de exterior.

Disassembling small table with rigid polyurethane base available in lacquered finishing or covered with hand-spread pastes finishes, as per price-list. Tops available in ceramic, lacquered MDF or covered with hand-spread finishes. Available in indoor and outdoor versions.

Table basse démontable avec base en polyurethane rigide disponible dans les finitions laquées ou matériaux spatulées selon liste de prix. Plateaux en céramique, MDF lacqué ou dans les finitions matériaux spatulées. Disponible dans les versions pour intérieur et extérieur.

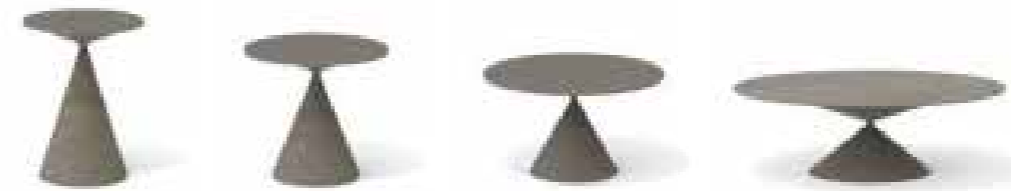

Mini Clay

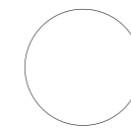

cm Ø 50  
cm Ø 60  
cm Ø 75

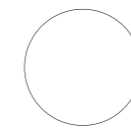

cm Ø 50  
cm Ø 60  
cm Ø 75

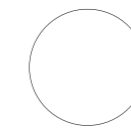

cm Ø 50  
cm Ø 60  
cm Ø 75

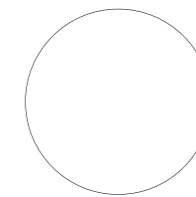

cm Ø 90  
cm Ø 110

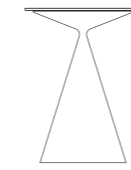

cm 37

cm 65



cm 37

cm 55

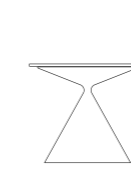

cm 37

cm 45

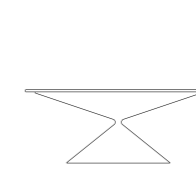

cm 50

cm 35

## Mixit + Mixit Glass

design Arik Levy  
2005/2007

### Mixit

Tavolino con piano in laminato stratificato o verniciato. Tubo e base in acciaio verniciato nello stesso colore del piano. Disponibile anche con piano in ceramica 6 mm, adatto anche per Outdoor.

Small table with layered laminate top or painted. Steel tube and base, painted in the same colour as the top. Available with ceramic tops 6 mm too, suitable also for Outdoor.

Tischchen mit Platte aus Schicht-laminat oder lackiert. Rohr und Basis in lackiertem Stahl in der Farben der Platte. Verfügbar auch mit Platte aus Keramik 6 mm, auch für Outdoor geeignet.

Table basse avec plateau en laminé stratifié ou verni. Tube et base en acier verni dans la même couleur que le plateau. Disponible aussi avec plateau en céramique 6 mm, utilisable aussi à l'extérieur.

Mesita con sobre en laminado estratificado o barnizado. Tubo y base en acero barnizado del mismo color del sobre. Disponible también con sobre en cerámica 6 mm, utilizable también en el exterior.

### Mixit Glass

Tavolino con tubo e base in acciaio laccato oppure nelle finiture esclusive Desalto. Piano di cristallo temperato 10 mm.

Small table with tube and base of lacquered steel or with the exclusive Desalto's finishes. Toughened glass top 10 mm.

Tischchen mit Gestell und Basis in lackiertem Stahl oder in den exklusiven Desalto Ausführungen. Platte aus temperiertem Glas 10 mm.

Petite table avec tube et base en acier laqué ou dans les finitions exclusives Desalto. Plateau en verre trempé 10 mm.

Mesita con tubo y base en acero lacado o en los exclusivos acabados Desalto. Sobre en cristal templado 10 mm.



Mixit



Mixit Glass

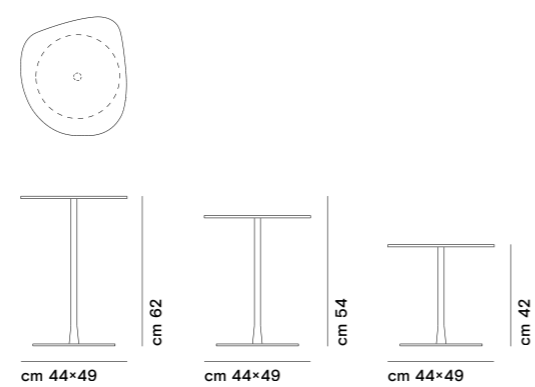
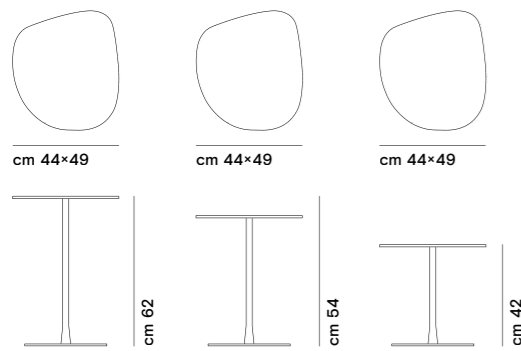

## Softer than Steel

design Nendo  
2014

Tavolini con piano in lamiera e gambe in tondino di acciaio laccato. Disponibile nelle versioni indoor e outdoor.

Small tables with metal sheet top and lacquered rod steel legs. Available in indoor and outdoor versions.

Tischchen mit Metalplatte und Beinen aus lackiertem Rundstahl. Verfügbar für In- und Outdoor.

Tables basses en métal et pieds en tube d'acier laqué. Disponible dans les versions pour intérieur et extérieur.

Mesitas con sobre en chapa y patas en tubo de acero lacado. Disponible en las versiones de interior y de exterior.



Softer than Steel

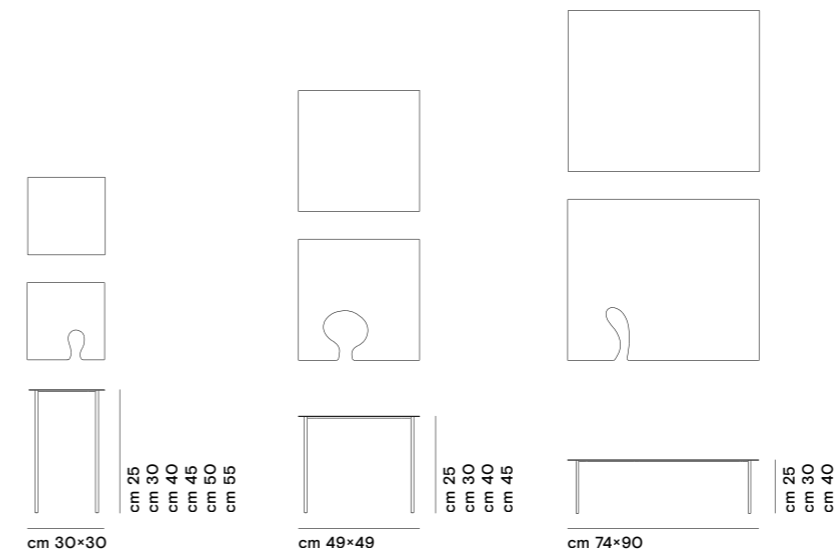

## Void

design Guglielmo Poletti  
2019

Tavolino realizzato in lamiera di acciaio spessore 3 mm. Console realizzata in lamiera di acciaio spessore 4 mm. Console fissata a parete realizzata in lamiera di acciaio spessore 3 mm.

Couchtisch aus Stahlblech Stärke 3 mm. Console aus Stahlblech Stärke 4 mm. Wand Console aus Stahlblech Stärke 3 mm.

Mesita realizada en chapa de acero espesor 3 mm. Consola realizada en chapa de acero espesor 4 mm. Consola con fijación a la pared realizada en chapa de acero espesor 3 mm.

Small table in sheet steel 3 mm thickness. Console in sheet steel 4 mm thickness. Console fixed to the wall in sheet steel 3 mm thickness.

Table basse avec feuille d'acier épaisseur 3 mm. Console en feuille d'acier épaisseur 4 mm. Console fixée au mur avec feuille d'acier épaisseur 3 mm.



Void

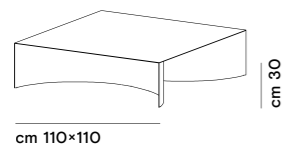

tavolino / small table

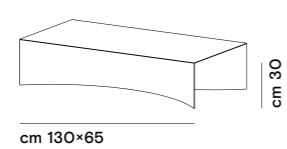

tavolino / small table

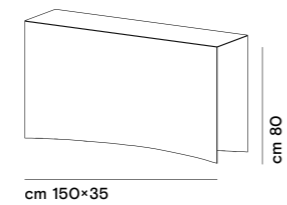

freestanding console

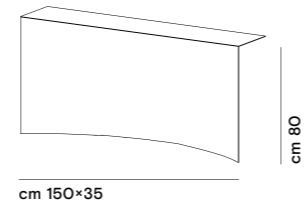

console a parete / wall-mounted console

## Crown

design Stefan Schöning  
2002

Appendiabiti da terra con struttura in tondino di acciaio laccato.

Coat stand with lacquered rod steel frame.

Kleiderständer mit lackiertem Stahlgestell.

Porte manteau avec structure en acier laqué.

Perchero con estructura en acero lacado.



Crown

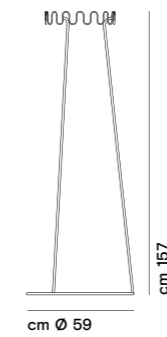

## Dadi

design Gianluigi Landoni  
2004

Oggetto multifunzione con struttura in lamiera di acciaio curvata verniciata.

Beistelltischchen aus Stahl, gebogen und lackiert.

Objeto multifuncional con estructura en acero, curvada y barnizada.

Multifunctional object with curved steel frame painted.

Objet multifonctionnel avec structure en acier, biseauté et vernie.



Dadi

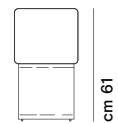
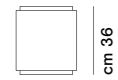

cm 36

## Helsinki

design Caronni + Bonanomi  
1998

Sistema di carrelli con struttura smontabile in acciaio sezione 30×30 mm e giunti in pressofusione. Struttura nelle finiture laccato opaco. Piani in metallo, laminato Fenix®, ceramica o essenza.

Rollwagensystem mit Stahlgestell Querschnitt 30×30 mm, Verbindungselemente aus Druckguss. Gestell in den matt lackierten Ausführungen. Platten aus Metal, Fenix® Laminat, Keramik oder Holz.

Sistema de carros con estructura desmontable en acero sección 30×30 mm y juntas en fusión de aluminio. Estructura en los acabados lacados mate. Encimeras enchapa de acero, laminado Fenix®, cerámica o madera.

Range of trolleys with disassembling steel frame section 30×30 mm and die-cast joints. Frame in the matt lacquered finishing. Tops available in metal, Fenix® laminate, ceramic or wooden tops.

Système de chariots avec structure démontable en acier section 30×30 mm et joints moulés sous pression. Structure dans les finitions mates laquées. Plateaux en métal, laminé Fenix®, céramique ou en bois.



Helsinki



dettaglio / detail

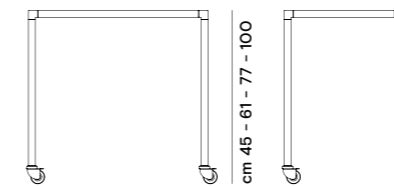

cm 78

cm 52

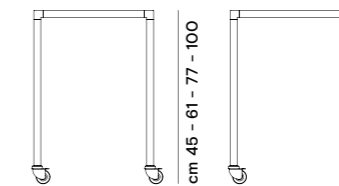

cm 52

cm 52

struttura base / basic structure



## Mir

design Marco Acerbis  
2017

Specchiera con cornice in estruso di alluminio. Mensola portaoggetti in MDF. I colori di cornice e mensola sono liberamente abbinabili tra loro. La cornice è predisposta per l'inserimento di una striscia LED da alloggiare lungo il perimetro esterno in un vano dotato di coperchio in policarbonato opalino. Kit striscia LED (optional).

Spiegel mit Rahmen aus extrudiertem Aluminium. Boden mit Handschuhfach aus MDF. Die Farben von dem Boden und dem Container können frei kombiniert werden. Der Montagerahmen ist dafür vorbereitet, dass man auf Wunsch an der externen Längsseite einen LED-Strang einsetzen kann, um ihn dann durch eine Abdeckung aus opalen Polycarbonat hindurch indirekt zu beleuchten. LED Strang (Auswahl).

Espejo con marco en aluminio. Compartimento porta-objetos en MDF. Los colores del marco y del compartimento se pueden combinar libremente entre ellos. El marco está preparado para insertar una cinta de leds que se aloja en todo el perímetro externo del hueco con un protector en policarbonato opaco. Cinta de leds (opcional).

Wall mirror with frame in extruded aluminium. MDF glove box. The colours of the frame and the shelf can be freely combined together. The frame is drawn up for the integration of a LED light to be put around the outside perimeter into a compartment with a lid in opaline polycarbonate. LED strip Kit (optional).

Miroir avec cadre en aluminium extrudé. Case porte-objet en MDF. Les couleurs du cadre et de la case peuvent être librement assorties entre elles. Le cadre est prédisposé pour l'introduction d'une bande LED, qui doit être logée le long du périmètre extérieur, dans une ouverture avec couvercle en polycarbonate opalin. Bande LED (optional).

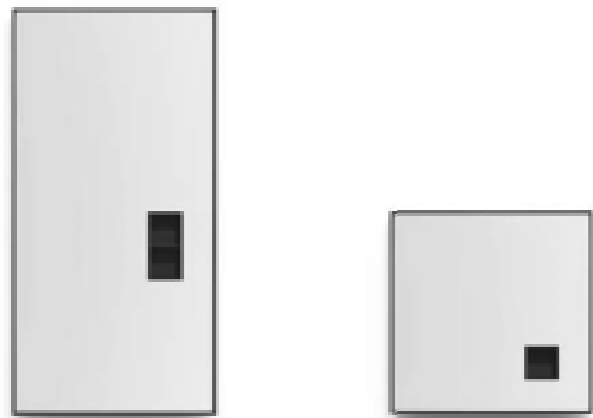

Mir

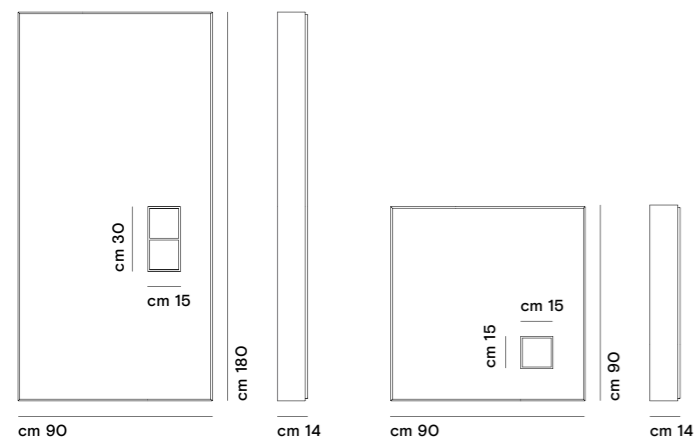

## Quartz

design Arik Levy  
2018

Composizione di più specchi (4 sagome) spessore 5 mm con bisellatura 30 mm.

Komposition mit vielen Spiegeln (4 verschiedene Formen) Stärke 5 mm mit 30 mm geschliffener Kante.

Composición de varios espejos (4 formas) espesor 5 mm con borde biselado de 30 mm.

Composition of several mirrors (4 different shapes) 5 mm thick, with bevelled edge of 30 mm.

Composition de plusieurs miroirs (4 formes différentes), épaisseur 5 mm avec borde biseauté 30 mm.



Quartz

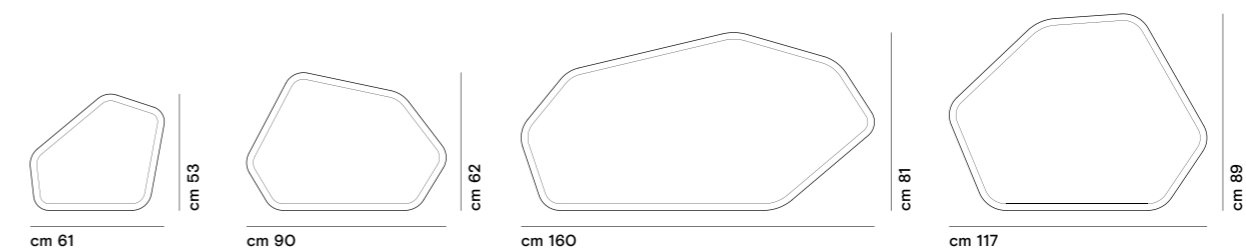

## Softer than Steel

design Nendo  
2014

Appendiabiti in barra di acciaio  
laccato.

Kleiderständer aus Rundstahl,  
lackiert.

Perchero en acero lacado.

Coat stand in lacquered  
steel bar.

Portemanteau en tube d'acier  
laqué.

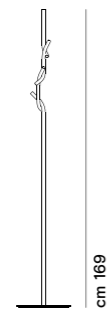
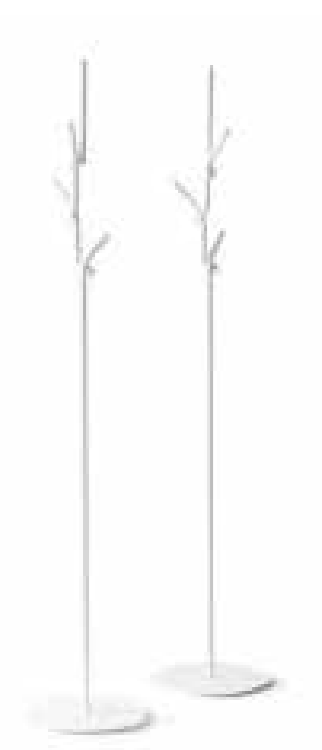

cm 30x32

cm 189

Softer than Steel

## Unus

design Elisa Ossino  
2014

Tavolino-seduta realizzato  
in MDF rifinito tramite applicazione  
manuale di resine, spatolate  
a mano.

Couchtisch aus MDF bezogen  
mit handgespachtelten  
Harzoberflächen.

Mesita-asiento en MDF refinado  
mediante la aplicación manual de  
resinas espatuladas a mano.

Small table-seating in MDF  
covered with hand-spread resin.

Table basse/assise en MDF laqué  
ou fini à travers de l'application  
manuelle de résines spatulées.



Unus



cm 25

cm 35

cm 45

desalto collections

graphic design  
Designwork

styling  
Maria Gabriella Zecca

photographs  
locations  
Andrea Ferrari  
still life  
Cesare Chimenti

still images  
Studio NOVE.3

text  
Elisa Testori  
translation  
Studio Intra

colour separation  
Lucegroup

printed in Italy by  
Grafica Gioia

06.2022 ©Desalto Spa

thanks to

Angelo and Diego Saini  
Alex Corno  
Amini  
Artemide  
Beatrice Carolina  
Bottega del Monaco  
Bottega Intreccio  
Bosa  
Ceramicah-  
Sarah Richiuso  
Cuore Carpenito  
Danese  
Davide Groppi  
Flos  
Francesca Verardo  
Henzel Studio  
Hk Living  
Kiasmo  
Kn Insustrie  
Luceplan  
Mamate  
Mani  
Margherita Fanti  
Nataly Maier  
courtesy Arte Silva

Natale Addamiano  
courtesy Deep Art Gallery  
Nemo lighting  
Nodus  
Paola Staccioli  
Penta Light  
Pino Pinelli  
courtesy Deep Art Gallery  
Rotaliana  
Sara Scalzotto  
Serax  
Sonia Scaccabarozzi  
Terrecotte Lotti  
Wolfram Ullrich  
courtesy Deep Art Gallery

Desalto Spa  
via per Montesolaro  
22063 Cantù – CO  
Italy

t +39 031 7832211  
f +39 031 7832290  
info@desalto.it  
desalto.it



