

MONOLITH



LA SCOCCA IN ALLUMINIO ESTRUSO CHE COSTITUISCE L'OSSATURA PORTANTE DI MONOLITH, CONSENTE GRANDE RIGIDITÀ STRUTTURALE E UNA LIBERA CONFIGURAZIONE DELLE PARTIZIONI INTERNE. TALE SISTEMA COSTRUTTIVO FORMA UN INSIEME MOLTO SEMPLICE DA ASSEMBLARE E RICONFIGURARE, EVITANDO DI RADDOPPIARE GLI SPESSORI DEI FIANCHI AL SUO INTERNO.

The frame in extruded aluminium forming the support structure of Monolith gives an extremely firm structure with free configuration of the inner partitions. This composition system forms a very simple set to assemble and re-configure, without doubling the thicknesses of its inner sides.

Le châssis en aluminium extrudé qui constitue l'ossature portante de monolith, permet une grande rigidité structurelle et une libre configuration des divisions internes. Ce système de construction forme un ensemble très simple à assembler et reconfigurer, en évitant de doubler les épaisseurs des côtés à l'intérieur.

Der Aufbau aus extrudiertem Aluminium, der das tragenden Gerüst des monolith darstellt, bietet eine bedeutende, strukturelle Steifheit und eine freie Konfigurierung der Innenaufteilung. Dieses Konstruktionssystem bildet eine Einheit, die einfach zusammenzubauen und neu zu gestalten ist, wobei die Verdoppelung der Stärke der Seiten im Innenbereich vermieden wird.

El bastidor de aluminio extruido que constituye el armazón de soporte de Monolith permite una gran resistencia estructural y una libre configuración de las particiones interiores. Este sistema de construcción forma un conjunto muy fácil de montar y reconfigurar, evitando duplicar el espesor de los laterales en su interior.



PRODUCT CONCEPT

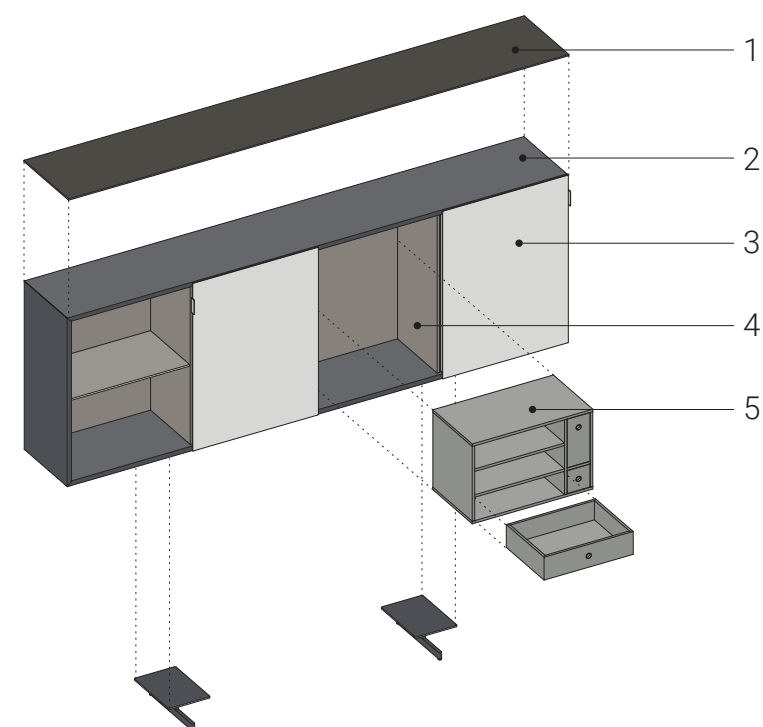

L modules
121.6 - 181 - 240.4

H modules
42.6 - 81 - 119.4 - 162

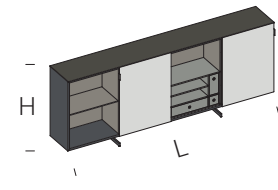

È possibile la sovrapposizione ed affiancamento dei moduli

The modules can be overlapped or side-by-side.

Les modules peuvent être superposés et placés les uns à côté des autres

Die Module können nebeneinander und übereinander montiert werden

Son posibles los módulos superpuestos y adosados.

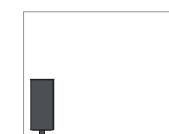

Pavimento / parete
Floor / wall
Sol / mur
Boden / Wand
Suelo / pared

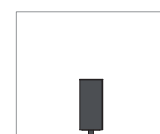

Centro stanza
Room divider units
Centre de la pièce
Zimmermitte
Centro de la habitación



Passacavi disponibili su pannello schiena e contenitori interni.
Cable sleeves available on the back panel and internal containers
Passe-câbles disponibles sur le panneau arrière et pour les conteneurs internes.
Kabeldurchgänge auf Rückenplatte und inneren Behältern möglich.
Pasacables disponibles en el panel trasero y en los contenedores internos.



Il top di spessore 6mm è disponibile in molteplici finiture, e protegge la superficie in alluminio della scocca ed il bordo dell'anta.

The 6 mm thick top is available in many finishes and protects the aluminium surface of the frame and the edge of the doors.

Le plateau de 6 mm d'épaisseur est disponible en plusieurs finitions et protège la surface en aluminium de la coque ainsi que le bord de la porte.

Das 6 mm dicke Abschlussbord ist in zahlreichen Beschichtungen verfügbar und schützt die Aluminiumoberfläche des Grundelements und den Türtrand.

La parte superior de 6 mm de grosor está disponible en varios acabados, y protege la superficie de aluminio del cuerpo y el borde de la puerta.

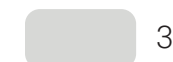

I frontali sono in vetro temprato di soli 4mm di spessore, disponibili nelle finiture laccato e laccato metallo. La semplificazione delle geometrie rende il volume delle madie compatto e raffinato.

The front panels are in 4 mm thick tempered glass, available in lacquered and metal lacquered finishes. The simplicity of the geometries makes the volume of the sideboards compact and elegant.

Les façades sont en verre trempé de seulement 4 mm d'épaisseur, disponibles dans les finitions laquées et laquées métal. La simplification des géométries permet aux buffets de présenter un volume compact et raffiné.

Die Stirnseiten sind aus nur 4 mm dickem Hartglas und sind in den Beschichtungen lackiert und metall-lackiert verfügbar. Die Vereinfachung der Formen machen das Volumen der Schrankkombinationen kompakt und raffiniert.

Los frentes son de vidrio templado de sólo 4 mm de espesor, disponibles en acabados lacado y lacado metálico. La simplificación de las geometrías hace que el volumen de los aparadores sea compacto y refinado.



La scocca perimetrale delle madie monolith è in alluminio estruso. La sezione d'estrusione è stata progettata in ogni minimo dettaglio per conferire rigidità e resistenza ai carichi con il minimo impiego di materiale.

The perimeter frame of the monolith sideboards is made of extruded aluminium. The extrusion section has been designed in detail to give it robustness and resistance to loads with a minimum use of material.

La coque de contour des buffets Monolith est en aluminium extrudé. La section d'extrusion a été conçue dans les moindres détails pour lui conférer rigidité et résistance aux charges en utilisant le moins de matériau possible.

Der Außenkorpus der Schrankkombinationen monolith ist aus extrudiertem Aluminium. Der Extrusionsschnitt wurde in jedem kleinsten Detail entworfen, um die höchste Festigkeit und Belastbarkeit bei der niedrigsten Menge an verwendetem Material zu erhalten.

El armazón perimetral de los aparadores Monolith es de aluminio extruido. La sección de extrusión ha sido diseñada en todos sus detalles para dar rigidez y resistencia a las cargas con el mínimo uso de material.



La monoscocca perimetrale in alluminio consente di non raddoppiare i fianchi interni in MDF, rendendo raffinato l'interno della madia anche con soluzioni a vista.

The aluminium perimeter single-frame means that the internal MDF sides do not have to be doubled, making the inside of the sideboard elegant, also with open compartment solutions.

La mono-coque de contour en aluminium permet de ne pas doubler les panneaux latéraux internes en MDF, rendant l'intérieur du buffet raffiné également pour les solutions à vue.

Der selbsttragende Außenkorpus aus Aluminium ermöglicht es, die inneren Seiten aus MDF nicht zu verdoppeln und so ist die Schrankkombination auch mit offenen Lösungen raffiniert.

El monocasco perimetral de aluminio hace que los laterales internos de MDF no se dupliquen, haciendo que el interior del aparador sea refinado incluso con soluciones visibles.



Sono disponibili contenitori a più vani con cassetti interni in finitura laccato ed essenza, che possono essere posizionati all'interno della madia anche successivamente all'installazione.

Multi-compartment containers with internal drawers with lacquered and wood finishes, that can be positioned inside the sideboard also following installation, are available.

Des conteneurs à plusieurs compartiments avec tiroirs internes en finitions laquées et bois sont disponibles, avec possibilité de les placer à l'intérieur du buffet également après l'installation.

Es sind Behälter mit mehreren Fächern verfügbar, mit inneren Schubladen, lackiert und in Holz nachbildung beschichtet, die auch nach der Montage in die Schrankkombination positioniert werden können.

Los contenedores con varios compartimentos están disponibles con cajones internos en acabados lacados y de madera, que pueden colocarse dentro del aparador incluso después de la instalación.

FINITURE/FINISHES

scocche / shells

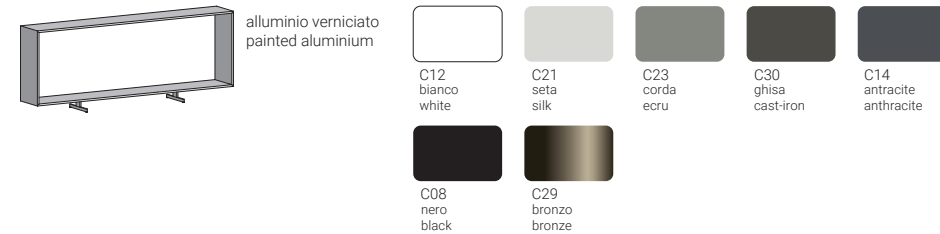

fianchi interni / inner sides



schiene / backs



ripiani interni / inner shelving

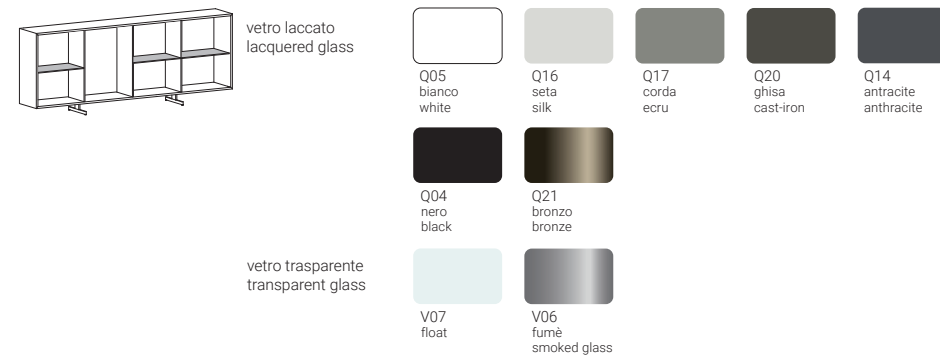

frontali / doors fronts

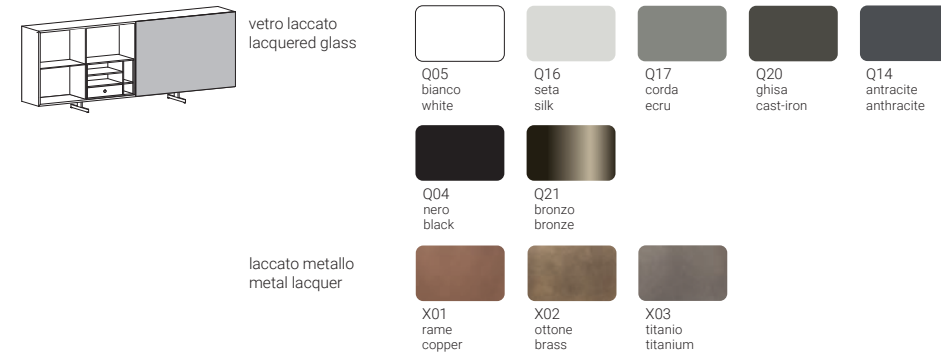

top

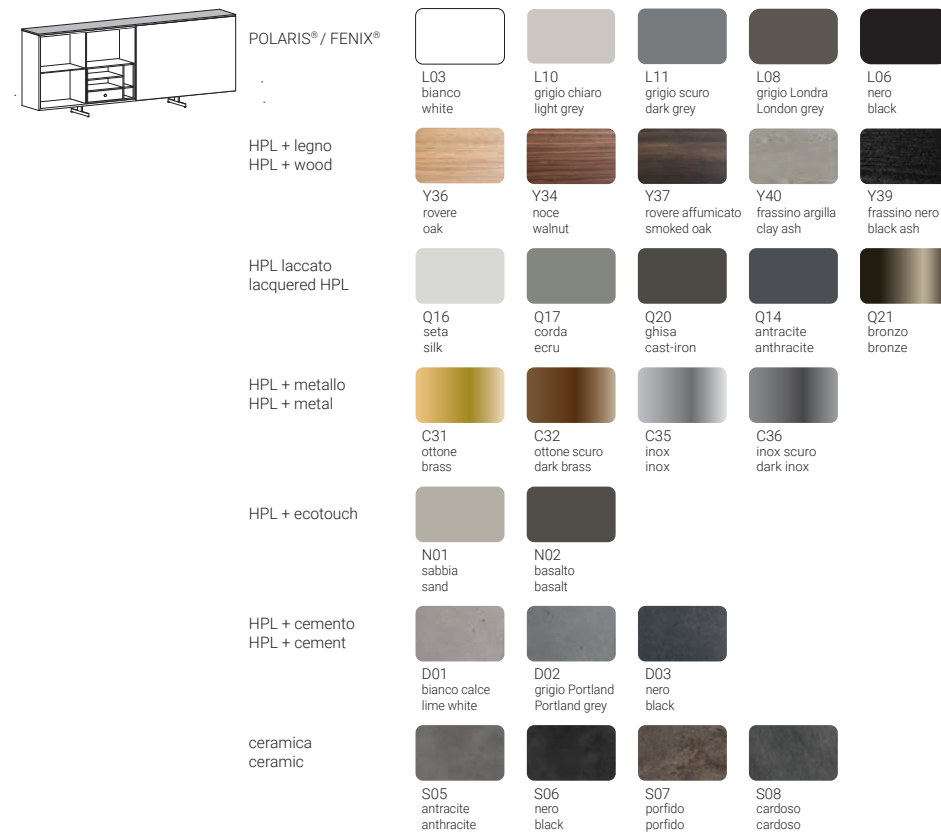

verificare a listino dimensioni e finiture
check dimensions and finishes in the price list

CONFIGURAZIONI / CONFIGURATIONS

H1 = 42.6 cm

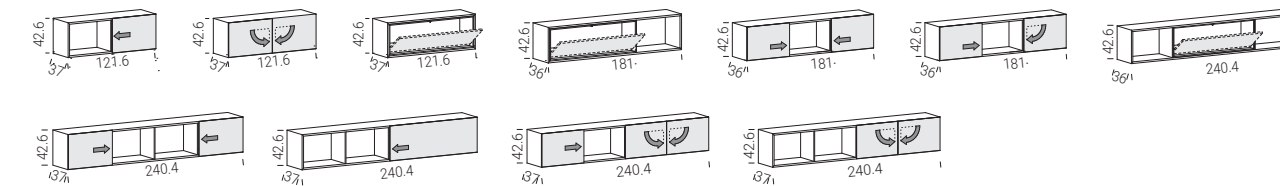

H2 = 81 cm

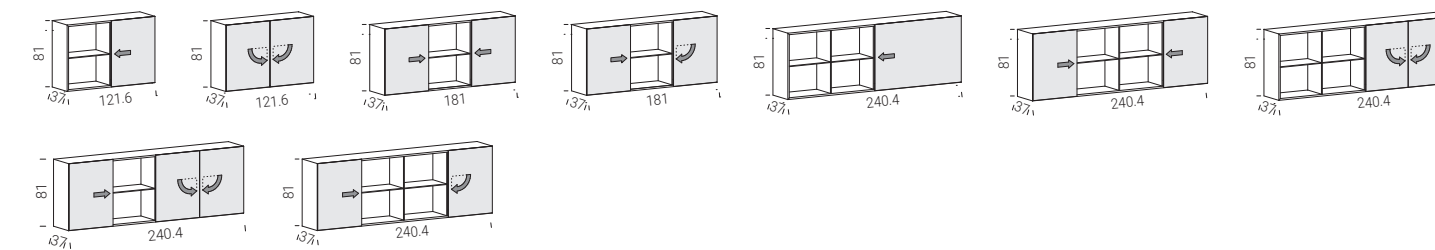

H3 = 119.4 cm

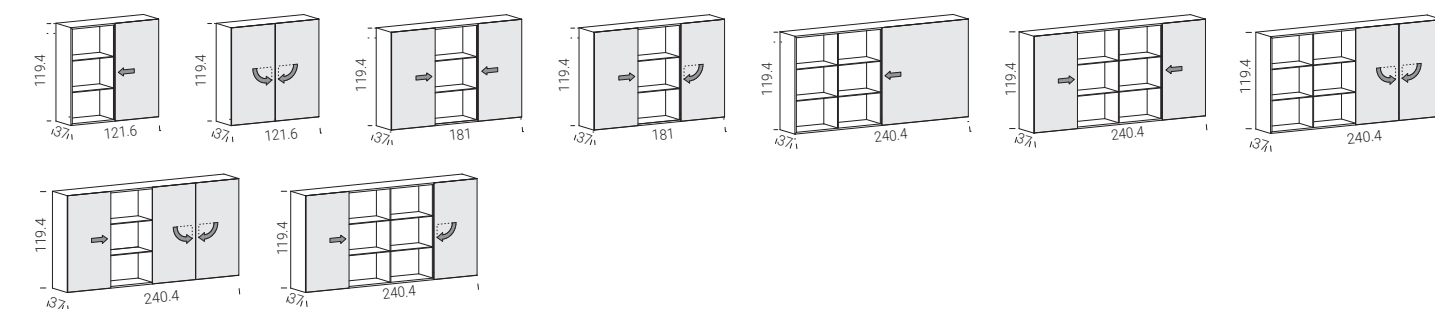

H4 = 162 cm

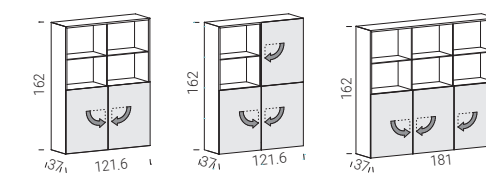

disponibili a listino ulteriori composizioni
further compositions available per pricelist

verificare a listino dimensioni e finiture
check dimensions and finishes in the price list

accessori / accessories

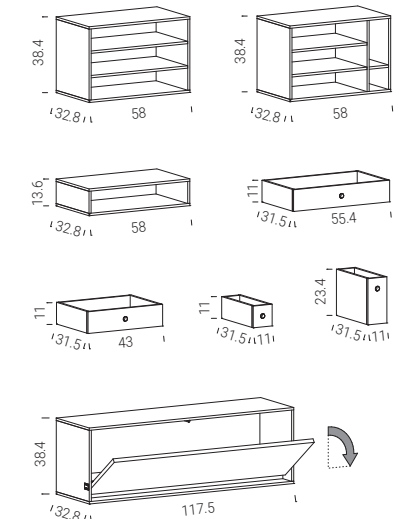

basi / bases

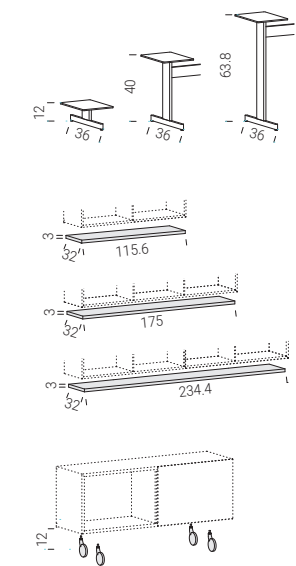

11/MONOLITH

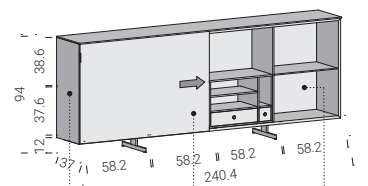

-  C30
cast-iron
-  X03
titanium
-  Y34
walnut

EWS pg. 26



ECH4 pg. 308



CONTRAPPESO pg. 340

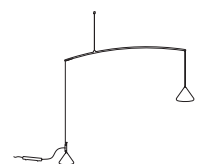

09/MONOLITH

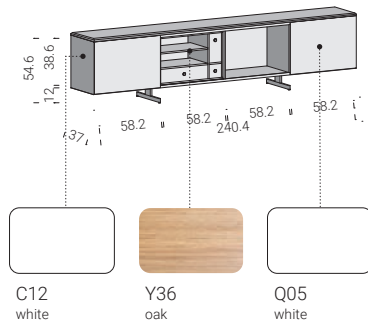



04/MONOLITH

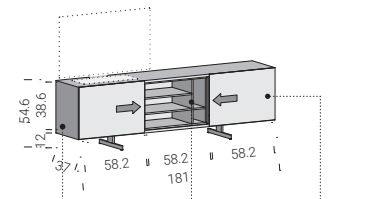

- C14 anthracite
- Y34 walnut
- Q14 anthracite



10/MONOLITH

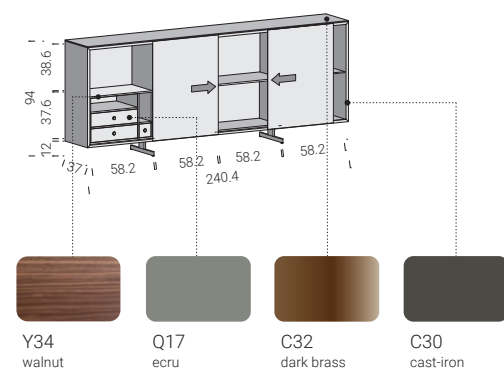

MONOLITH

- Caratteristiche costruttive
- Construction characteristics
- Caractéristiques de construction
- Konstruktionsmerkmale
- Características constructivas



06/MONOLITH

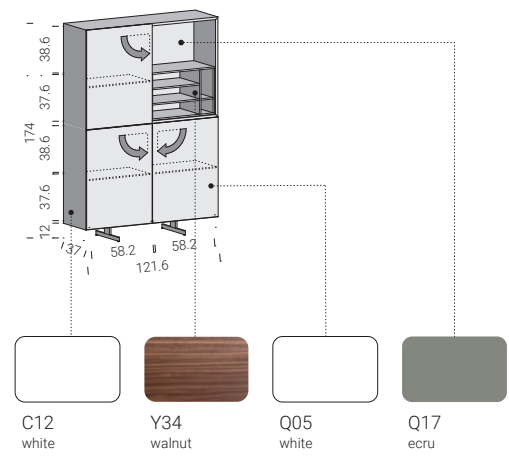

02/MONOLITH

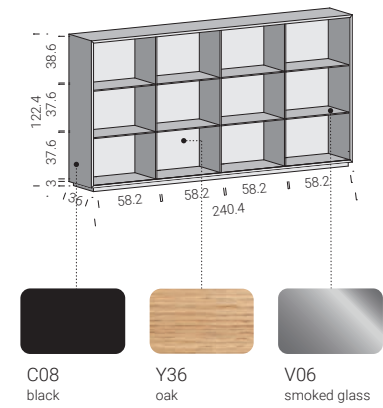

HAMMER pg. 210

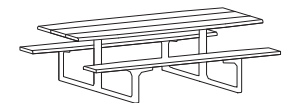

02A/MONOLITH

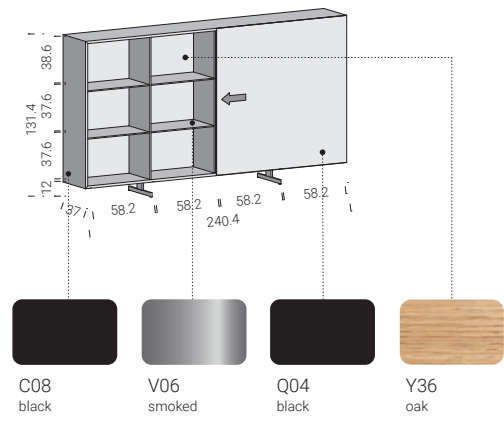

SPILLO pg. 158



05/MONOLITH

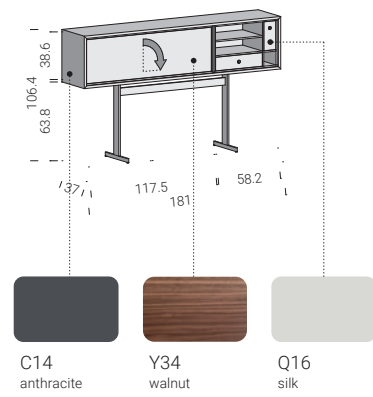

MONOLITH
• Scrivitoio
• Writing desk
• Bureau
• Schreibtisch
• Escritorio