



# DESIGN CONCEPT

QUANDO IMMAGINIAMO UN NUOVO PRODOTTO, RICERCHIAMO "L'EQUILIBRIO PERFETTO" TRA I MATERIALI CHE LO COMPONGONO, IL DESIGN DELLE FORME E LA FUNZIONALITÀ NEL QUOTIDIANO.

When we conceptualize a new product, we look for the "perfect balance" between the materials it is made from, the design of the forms and everyday practicality.

Lorsque nous imaginons un nouveau produit, nous recherchons « l'équilibre parfait » entre les matériaux qui le composent, ses formes et sa fonction au quotidien.

Wenn wir uns ein neues Produkt vorstellen, suchen wir „das perfekte Gleichgewicht“ zwischen den Materialien, aus denen es besteht, dem Design der Formen und der Zweckmäßigkeit im Alltag.

Cuando imaginamos un nuevo producto, buscamos el "equilibrio perfecto" entre los materiales que lo componen, el diseño de sus formas y su funcionalidad cotidiana.

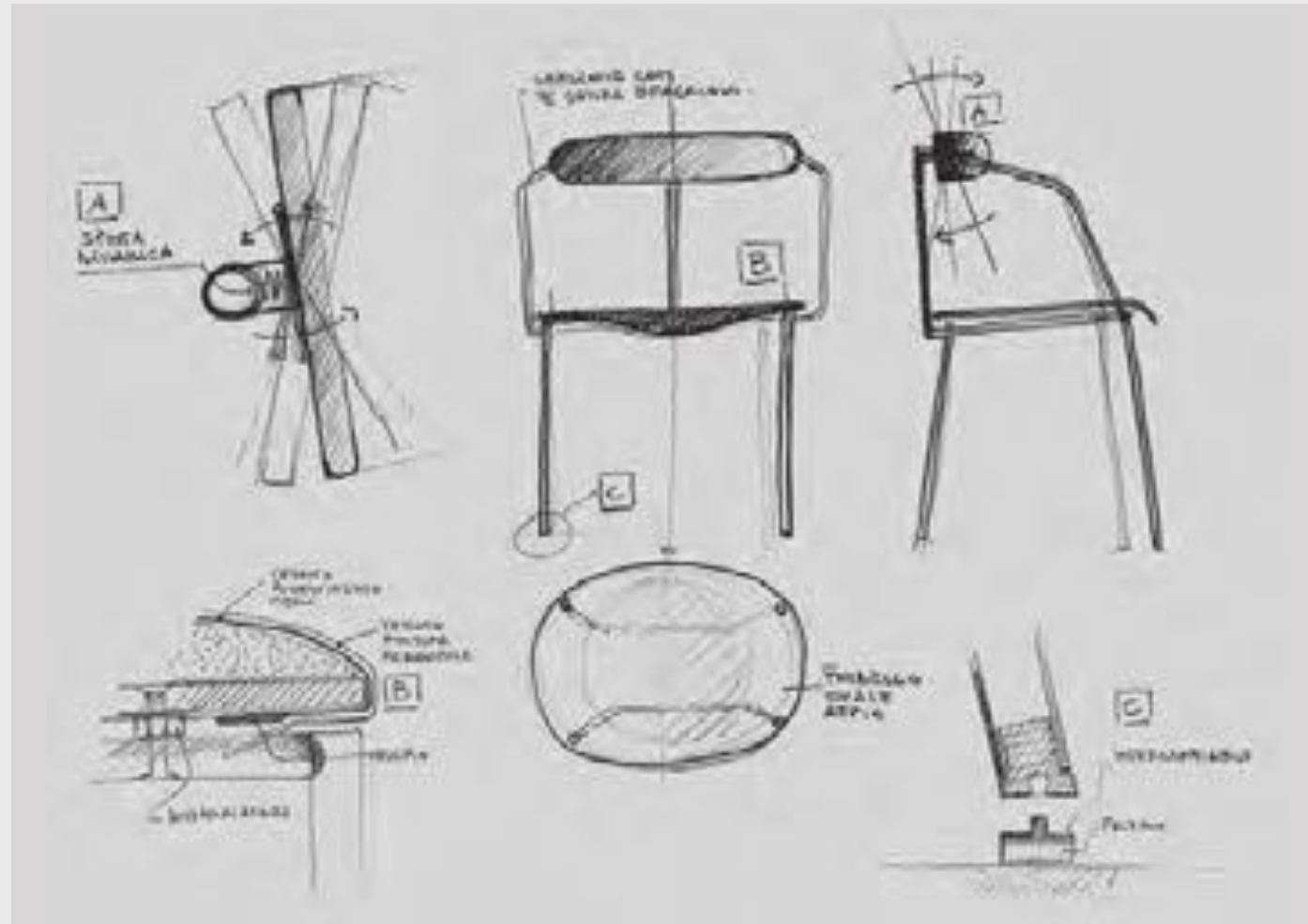

# DESIGN PROCESS

IL TEAM DI PROGETTO SVILUPPA ED AFFINA IL NUOVO CONCEPT DI PRODOTTO. LA FASE DI PROGETTAZIONE 3D PREVEDE LA CONDIVISIONE DELLE SPECIFICHE COMPETENZE DEI TEAM DI DESIGN ED INDUSTRIALIZZAZIONE.

The project team develops and fine tunes the new product concept. The specific know-how of the design and industrialization teams is pooled during the 3D design stage.

L'équipe de projet développe et affine le nouveau concept de produit. La phase de conception 3D prévoit un partage des compétences spécifiques des équipes de conception et d'industrialisation.

Das Projektteam entwickelt und verfeinert das neue Produktkonzept. Die 3D-Entwurfsphase sieht das Teilen von spezifischen Kompetenzen der Design- und des Industrialisierungsteams vor.

El equipo del proyecto desarrolla y perfecciona el nuevo concepto del producto. La fase de diseño en 3D implica la puesta en común de las competencias específicas del equipo de diseño e industrialización.

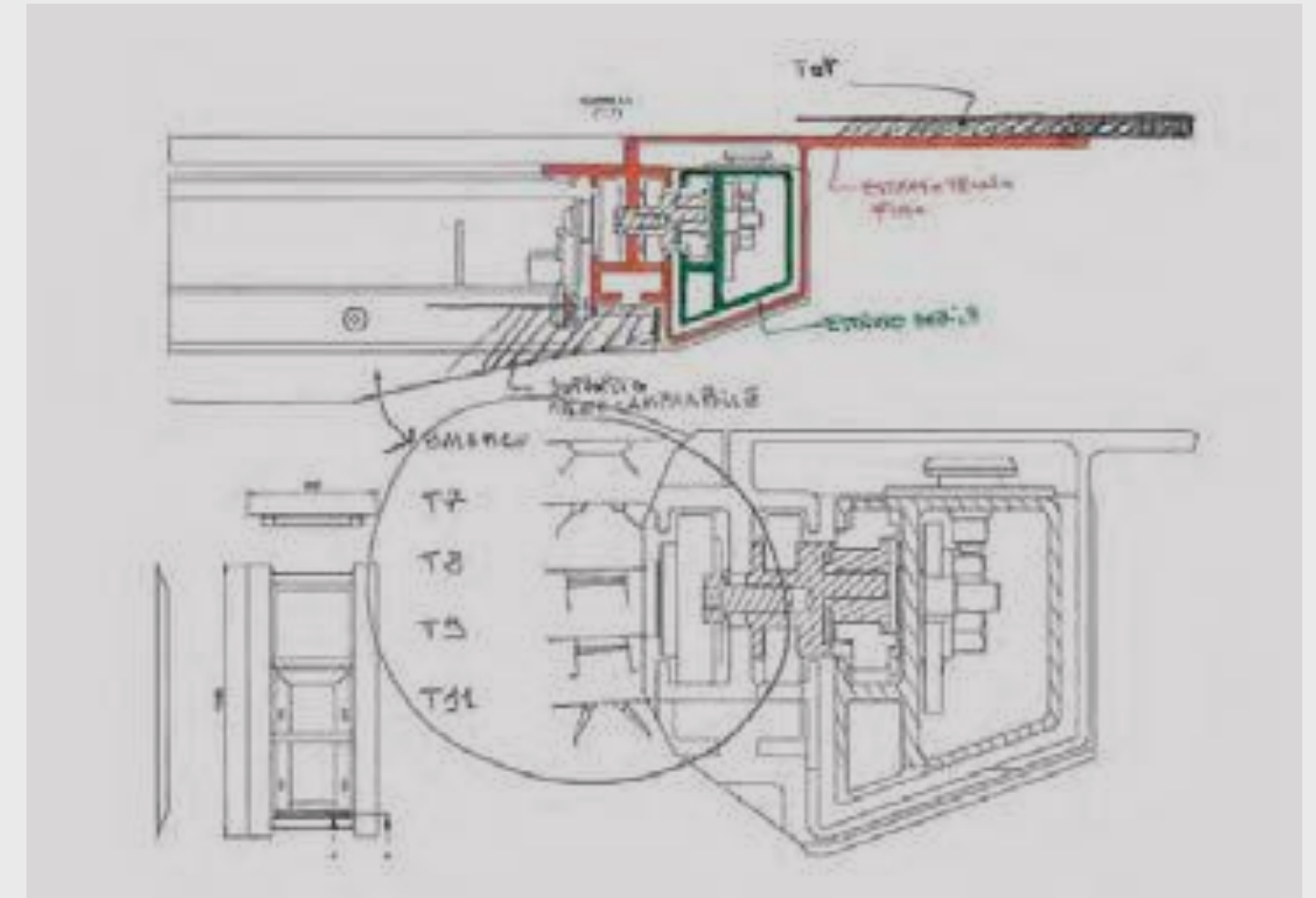

# INTELLECTUAL PROPERTY

LA PASSIONE PER I MATERIALI, LA PROGETTAZIONE MECCANICA E LA RICERCA DI NUOVE FUNZIONALITÀ APPLICATE AI SISTEMI D'ARREDO, DANNO VITA AI BREVETTI EXTENDO, BREVETTI DI INVENZIONE E DI DESIGN.

The passion for materials, mechanical design and the search for new functions applied to furnishing systems give life to the extendo patents, invention and design patents.

La passion pour les matériaux, la conception mécanique et la recherche de nouvelles fonctionnalités appliquées aux systèmes d'ameublement, donnent vie aux brevets Extendo, des brevets d'invention et de design.

Die Leidenschaft für die Materialien, das maschinelle Entwerfen und die Suche nach neuen Zweckmäßigkeiten für die Einrichtungssysteme rufen die Patente extendo ins Leben, Patente der Erfindung und des Designs.

La pasión por los materiales, el diseño mecánico y la búsqueda de nuevas funcionalidades aplicadas a los sistemas de mobiliario dan lugar a patentes Extendo, de invención y de diseño.

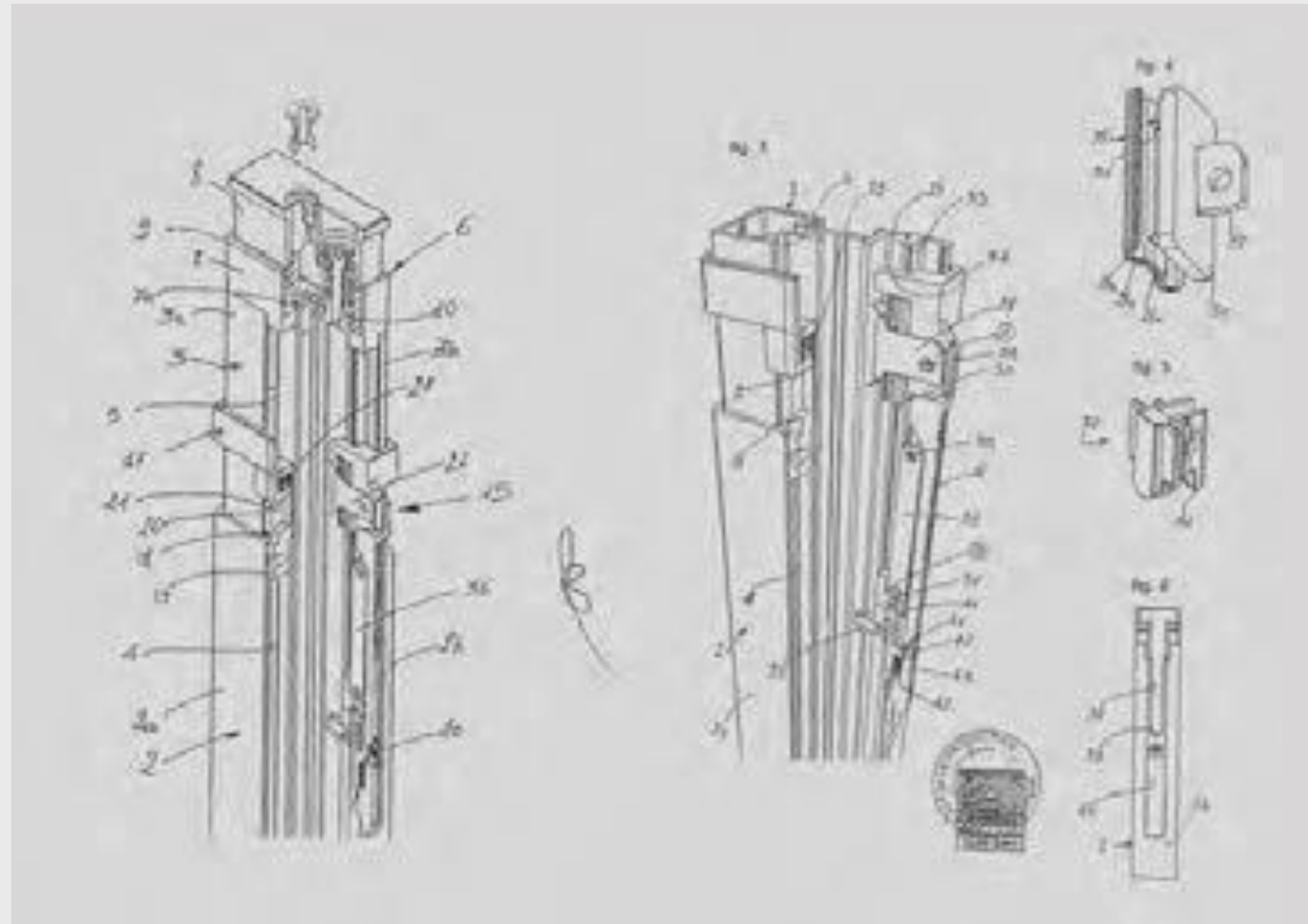

# RESEARCH & DEVELOPMENT

LA SCELTA DELLA MATERIA PRIMA INFLUENZA IL PROCESSO CREATIVO SIN DALLA SUA GENESI. IL TEAM DI PROGETTO EXTENDO PONE MOLTA ATTENZIONE ALLA RICERCA DEI MATERIALI IMPIEGATI PER LA COSTRUZIONE DI OGNI PRODOTTO.

The choice of the raw material guides the creative process from the outset. The Extendo project team pays great attention to the search for the materials to use for each product.

Le choix de la matière première influence le processus de création dès sa genèse. L'équipe de projet Extendo accorde une grande attention à la recherche des matériaux utilisés pour la construction de chaque produit.

Die Wahl des Rohstoffes beeinflusst den kreativen Prozess schon von Anfang an. Das Projektteam von extendo lenkt große Aufmerksamkeit auf die Suche nach den für die Herstellung eines jeden Produktes verwendeten Materialien.

La elección de la materia prima influye en el proceso creativo desde el principio. El equipo de proyectos de Extendo presta mucha atención a la investigación de los materiales utilizados en la construcción de cada producto.



SYSTEM patented



XY patented



EXTENDABLE TABLE SYSTEM registered community design



ADAPTIVE CHAIR BACKREST registered community design



CONTRAPPESO registered community design

# CONSTRUCTION DETAILS

I CONCETTI INNOVATIVI DI PRODOTTO D'ARREDO PRENDONO VITA GRAZIE AD UN DESIGN TEAM CHE IN-HOUSE SVILUPPA E DETTAGLIA I CONCEPTS CREATIVI, MANTENENDO COERENZA NEL LINGUAGGIO STILISTICO IN TUTTE LE COLLEZIONI EXTENDO.

Innovative furniture product concepts are brought to life by a design team that develops and outlines creative concepts in-house, coherently with the stylistic language of all the Extendo collections.

Les concepts innovants de produits d'ameublement prennent vie grâce à une équipe de conception qui développe des concepts créatifs en interne, en maintenant la cohérence du langage stylistique de toutes les collections Extendo.

Die innovativen Konzepte für Einrichtungsprodukte entstehen dank einem Design-Team, das in-house die kreativen Konzepte entwickelt und ausführlich beschreibt und dabei in der stilistischen Sprache in allen extendo-Kollektionen die Kohärenz beibehält.

Los innovadores conceptos de productos de mobiliario cobran vida gracias a un equipo de diseño interno que desarrolla y detalla los conceptos creativos, manteniendo un lenguaje estilístico coherente en todas las colecciones de extendo.



# RAW MATERIALS AND PRODUCTION

EXTENDO ACQUISTA LE MATERIE PRIME CHE SODDISFANO I MIGLIORI STANDARD TECNICI E QUALITATIVI DIRETTAMENTE ALLA FONTE. DA ESSE VENGONO PRODOTTI MIGLIAIA DI COMPONENTI IN LEGNO, ACCIAIO, ALLUMINIO E VETRO, SOTTOFORMA DI SEMILAVORATI STOCCATI PRESSO I NOSTRI MAGAZZINI.

Extendo sources raw materials that meet the highest technical and quality standards. Using these materials, we make thousands of wood, steel, aluminium and glass components for semi-finished products which are then stored in our warehouses.

Extendo achète les matières premières répondant aux meilleurs standards techniques et qualitatifs directement à la source. Celles-ci permettent la production de milliers de composants en bois, acier, aluminium et verre, sous forme de produits semi-finis stockés dans nos entrepôts.

Extendo kauft die Rohstoffe, die den besten technischen und qualitativen Standards entsprechen, direkt an der Quelle. Aus diesen werden tausende Komponenten aus Holz, Stahl, Aluminium und Glas hergestellt, in Form von Halbfertigprodukten, die bei uns gelagert werden.

Extendo adquiere materias primas que cumplen las normas técnicas y de calidad más exigentes directamente de la fuente. A partir de ellas se fabrican miles de componentes de madera, acero, aluminio y vidrio en forma de productos semiacabados almacenados en nuestros almacenes.



## PRODUCTION

- Come produciamo
- Our Manufacturing Process
- Comment Produisons-Nous Nos Articles
- Wie Wir Produzieren
- Como Producimos

# 100% LOCALLY MADE

LA PRODUZIONE INTERNA INTEGRA L'ESPERIENZA E LA COOPERAZIONE DI ARTIGIANI PARTNER, I CUI LABORATORI SONO SITUATI A BREVE RAGGIO DALLA NOSTRA SEDE PRODUTTIVA. QUESTO CONSENTE UNA CONDIVISIONE DEL KNOW-HOW, ED UNA RAPIDITÀ TRA I DIVERSI STEP DI FILIERA.

In-house production capitalizes on the experience and cooperation of partner artisans whose workshops are located within a short radius of our manufacturing plant. In this way, know-how is shared and the steps between the production chain are shortened.

La production interne intègre l'expérience et la coopération d'artisans partenaires, dont les ateliers sont situés à courte distance de notre site de production. Cela permet un partage de savoir-faire, et une rapidité entre les différentes étapes de la chaîne d'approvisionnement.

Die interne Produktion integriert die Erfahrung und die Zusammenarbeit mit Partnerhandwerkern, deren Werkstätten im nahen Umkreis von unserer Produktionsstätte liegen. Das ermöglicht das Teilen des Knowhows und Schnelligkeit zwischen den verschiedenen Stufen der Produktionskette.

La producción interna incorpora la experiencia y la cooperación de socios artesanos, cuyos talleres están situados en un radio de corto alcance respecto de nuestro centro de producción, lo que permite compartir conocimientos técnicos y rapidez entre los distintos pasos de la cadena de producción.

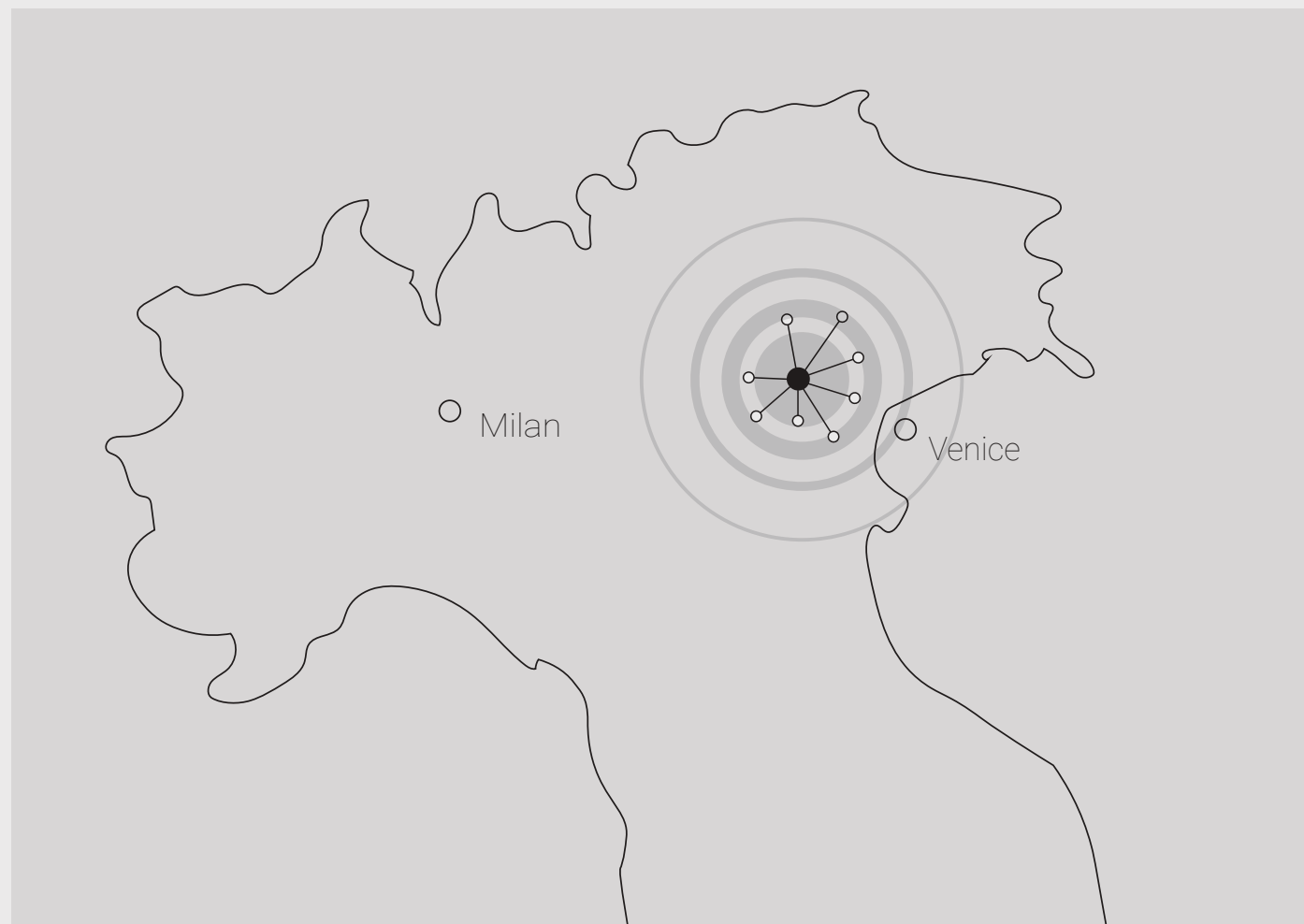

# TAILORED PRODUCTS

IN FASE DI PROGETTO, IL CLIENTE SCEGLIE I MATERIALI, LE FINITURE E LE DIMENSIONI DEL PRODOTTO CHE INTENDE ACQUISTARE. TALI INFORMAZIONI NEI DIVERSI STEP PRODUTTIVI DARANNO VITA ALLA PERSONALIZZAZIONE DEL PRODOTTO FINALE.

In this project stage, the clients choose the materials, finishes and dimensions of the product they want to buy. During the production process, this information leads to the personalization of the finished product.

Lors de la phase de conception, le client choisit les matériaux, les finitions et les dimensions du produit qu'il envisage d'acheter. Ces informations, durant les différentes étapes de production, permettront de personnaliser le produit final.

In der Entwurfsphase wählt der Kunde die Materialien, die Beschichtungen und die Maße der Produkte, die er kaufen möchte. Diese Informationen in den verschiedenen Produktionsphasen führen zur Individualisierung des Endprodukts.

En la fase de diseño, el cliente elige los materiales, los acabados y las dimensiones del producto que desea adquirir. Esta información en las distintas fases de producción dará lugar a la personalización del producto final.



# WHAT MAKES EXTENDO PRODUCTS UNIQUE

IL PROJECT TEAM IMPIEGA I MATERIALI E LE TECNOLOGIE DI TRASFORMAZIONE PIÙ INNOVATIVI PER DARE VITA ALLE NUOVE COLLEZIONI.

The project team uses state-of-the-art materials and transformation technologies to create the new collections.

L'équipe du projet utilise les matériaux et les technologies de transformation les plus innovants pour créer les nouvelles collections.

Das Projekt-Team verwendet die innovativsten Materialien und Verarbeitungstechnologien, um die neuen Kollektionen zu realisieren.

El equipo del proyecto utiliza los materiales y tecnologías de procesamiento más innovadores para crear nuevas colecciones.

LA PASSIONE PER LA RICERCA SUI MATERIALI, LE FORME E LE FUNZIONI È LA FONTE DEI BREVETTI DI DESIGN ED INVENZIONE DEI PRODOTTI EXTENDO.

Passion for the study of materials, forms and functions is the heart of the Extendo products' design and invention patents.

La passion pour la recherche sur les matériaux, les formes et les fonctions est à l'origine des brevets de conception et d'invention des produits Extendo.

Die Leidenschaft für die Forschung über die Materialien, die Formen und die Zwecke ist die Quelle der Patente des Designs und der Erfindung der Produkte von extendo.

La pasión por la investigación de materiales, formas y funciones es el origen de las patentes de diseño e invención de los productos Extendo.

IL DESIGN DEI PRODOTTI EXTENDO È UN SEGNO DISTINTIVO CHE ACCOMUNA TUTTE LE NOSTRE COLLEZIONI.

The design of Extendo's products is a distinctive feature that is common to all our collections.

Le design des produits Extendo est une caractéristique qui unit toutes nos collections.

Das Design der Produkte von extendo ist ein Markenzeichen, das alle unsere Kollektionen gemeinsam haben.

El diseño de los productos Extendo es un sello distintivo de todas nuestras colecciones.

LA POSSIBILITÀ DI POTER SCEGLIERE LE DIMENSIONI, I MATERIALI E LE FINITURE DI OGNI PRODOTTO, CREA ARMONIA TRA GLI ARREDI E L'ARCHITETTURA D'INTERNI.

Being able to choose the size, materials and finishes of each product creates harmony between furnishings and interior design.

La possibilité de choisir les dimensions, les matériaux et les finitions de chaque produit permet d'harmoniser l'ameublement et l'architecture intérieure.

Die Möglichkeit, die Maße, die Materialien und die Beschichtungen wählen zu können, schafft Harmonie zwischen der Einrichtung und der Innenarchitektur.

La posibilidad de poder elegir el tamaño, el material y el acabado de cada producto crea una armonía entre el mobiliario y la arquitectura interior.

I VASTI MAGAZZINI DI COMPONENTI E LE MATERIE PRIME ACQUISTATE ALLA FONTE DELLE FILIERE PRODUTTIVE, GARANTISCONO QUALITÀ E COMPETITIVITÀ AI PRODOTTI DELLE COLLEZIONI.

Our warehouses for components and raw materials purchased at the source of the production chains guarantee the quality and competitiveness of the products in the collections.

Les vastes entrepôts de composants et de matières premières achetés à la source des chaînes de production garantissent qualité et compétitivité aux articles composant les collections.

Die großen Lager mit Komponenten und Rohstoffen, die an der Quelle der Produktionsketten gekauft werden, gewährleisten den Produkten der Kollektionen Qualität und Wettbewerbsfähigkeit.

Los amplios stocks de componentes y materias primas adquiridos en el origen de las cadenas de producción garantizan la calidad y competitividad de los productos de las colecciones.



# EXTENDO GREEN MODEL

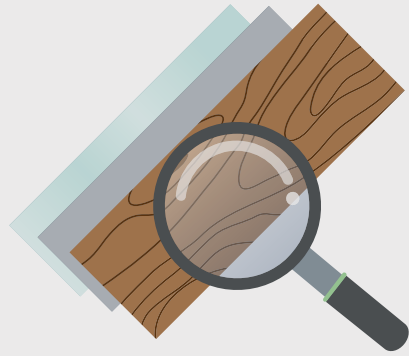

ALLUMINIO, ACCIAIO, LEGNO, VETRO, LA SCELTA DELLE MATERIE PRIME È PARTE INTEGRANTE DEL PROCESSO CREATIVO SIN DALLA SUA GENESI.

Whether aluminium, steel, wood or glass, the choice of raw material is a fundamental part of the creative process from the outset.

Aluminium, acier, bois, verre, le choix des matières premières fait partie intégrante de notre processus de création dès sa genèse.

Aluminium, Stahl, Holz, Glas, die Wahl der Rohstoffe ist wesentlicher Bestandteil des kreativen Prozesses schon von Anfang an.

Aluminio, acero, madera, vidrio, la elección de las materias primas forma parte del proceso creativo desde su génesis.



PER REALIZZARE I NOSTRI PRODOTTI UTILIZZIAMO MATERIE PRIME CHE DERIVANO IN PARTE O TOTALMENTE DA UN PROCESSO DI RIUTILIZZO E SONO A LORO VOLTA RICICLABILI.

For our products, we use raw materials partially or completely from re-use processes and which are, in turn, recyclable.

Pour fabriquer nos produits, nous utilisons des matières premières qui proviennent, en partie ou totalement, d'un processus de réutilisation, et sont à leur tour recyclables.

Zur Realisierung unserer Produkte verwenden wir Rohstoffe, die zum Teil oder ganz aus einem Wiederverwendungsprozess stammen und sind ihrerseits recycelbar.

Para fabricar nuestros productos, utilizamos materias primas parcial o totalmente reutilizables y reciclables.

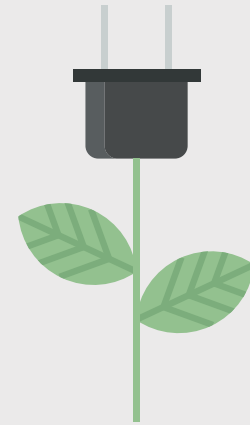

L'INTERA FILIERA PRODUTTIVA IMPIEGA ENERGIA DERIVANTE DA SORSE RINNOVABILI, AUTO-PRODOTTA O ACQUISTATA DA FONTI CERTIFICATE.

The entire production chain uses energy from renewable sources, either self-produced or procured from certified sources.

L'ensemble de la chaîne de production utilise de l'énergie provenant de sources renouvelables, autoproduite ou achetée auprès de sources certifiées.

Die gesamte Produktionskette nutzt Energie aus erneuerbaren Energiequelle, selbst erzeugt oder von zertifizierter Quelle gekauft.

Toda la cadena de producción utiliza energía procedente de fuentes renovables, de producción propia o comprada a fuentes certificadas.

Reducimos las emisiones del transporte de materias primas y productos semiacabados produciendo el 100% dentro de la empresa y con socios de producción en un radio de 15 km.



RIDUCIAMO LE EMISSIONI DERIVANTI DAI TRASPORTI DI MATERIE PRIME E SEMILAVORATI PRODUCENDO IL 100% IN EXTENDO E CON PARTNERS PRODUTTIVI NEL RAGGIO DI 15KM.

We reduce the emissions from the transport of raw materials and semi-finished products by producing them in-house or by using manufacturing partners located within a radius of 15 km.

Nous réduisons les émissions provenant du transport des matières premières et des produits semi-finis en concentrant l'intégralité de la production dans les locaux d'Extendo et en collaboration avec des partenaires de production situés dans un rayon de 15 km.

Wir reduzieren die Emissionen für den Transport der Rohstoffe und der Halbfertigprodukte, da wir alles bei extendo und mit Produktionspartnern im Umkreis von 15 km herstellen.

Reducimos las emisiones del transporte de materias primas y productos semiacabados produciendo el 100% dentro de la empresa y con socios de producción en un radio de 15 km.

# MATERIALS MIX IN THE ANNUAL PRODUCTION

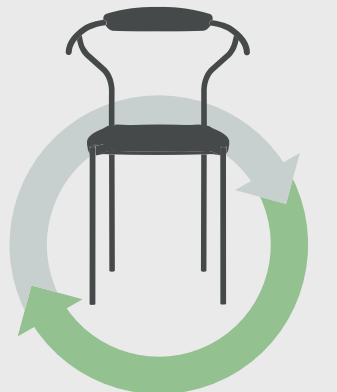
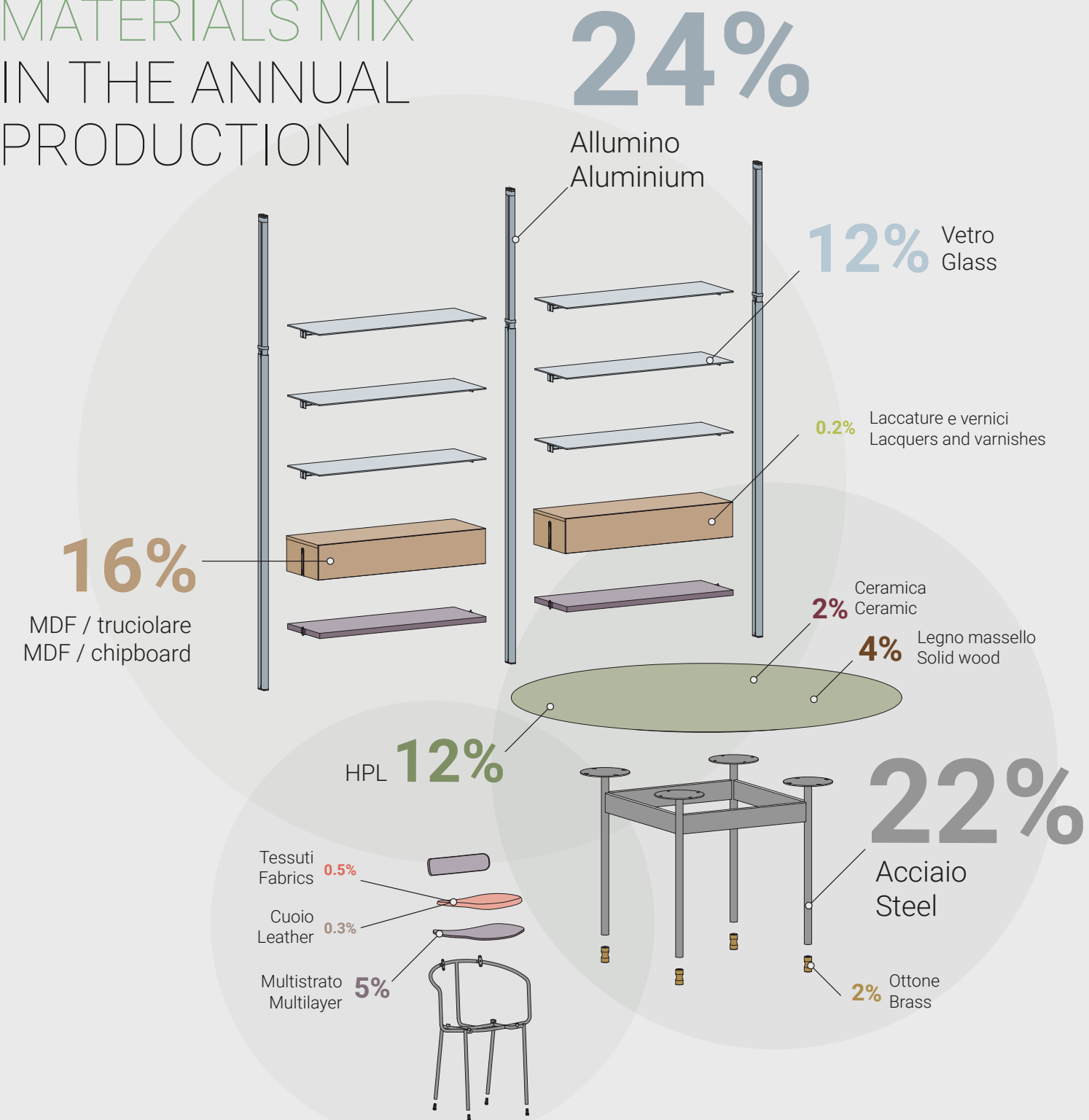

LE MATERIE PRIME RICICLATE PRENDONO NUOVA VITA SOTTO FORMA DI COMPONENTI D'ARREDO, PROGETTATI PER DURARE NEL TEMPO.

The recycled raw materials take on a new life as furnishing components, designed to last over time.

Les matières premières recyclées prennent une nouvelle vie sous la forme d'éléments de mobilier, conçus pour durer dans le temps.

Die recycelten Rohstoffe erhalten als Einrichtungskomponenten neues Leben und sie sind entwickelt, um eine lange Lebensdauer zu haben.

Las materias primas recicladas cobran nueva vida en forma de componentes de mobiliario diseñados para durar.

# GREEN MATERIALS



## 24% Alluminio / Aluminium

Estrusioni con geometrie complesse, pressofusioni rinforzate, lavorazioni meccaniche da barre piene.

Extrusions with complex geometries, reinforced die-casts, mechanical machining of full bars.

Extrusions à géométries complexes, moulages sous pression renforcés, usinage mécanique à partir de barres pleines.

Extrusionen mit komplexen Formen, verstärkte Pressgüsse, maschinelle Bearbeitung von Vollstangen.

Extrusiones con geometrías complejas, fundiciones a presión reforzadas, mecanizado a partir de barras macizas.



## 12% Vetro / Glass

Lastre in vetro spessore 10/6/4 mm. che attraverso il processo di tempra triplicano le prestazioni meccaniche.

10/6/4 mm thick glass plates that triple their mechanical performance through a tempering process.

Plaques de verre de 10/6/4 mm d'épaisseur qui, grâce au processus de durcissement, triplent leurs performances mécaniques.

Glasplatten Dicke 10/6/4 mm, die durch das Vorspannverfahren ihre mechanischen Leistungen verdreifachen.

Láminas de vidrio con un grosor de 10/6/4 mm que triplican sus prestaciones mecánicas mediante el proceso de templado.



## 4% Legno massello / Solid wood

Utilizziamo essenze provenienti da foreste con programma di riforestazione.

We use species from forests that endorse a reforestation programme.

Nous utilisons des bois issus de forêts dotées d'un programme de reboisement.

Wir verwenden Holzarten aus Wäldern mit einem Wiederaufforstungsprogramm.

Utilizamos madera procedente de bosques con programas de reforestación.



## 22% Acciaio / Steel

Acciaio laminato e trafilato, lavorato per fresatura e tornitura, taglio laser / laser 3D, presso-piegatura.

Rolled and drawn steel, machined for milling and turning, laser / 3D laser cutting and press-bending.

Acier laminé et étiré, traité par fraisage et tournage, découpe laser/laser 3D, pressage-plier.

Gezogener Walzstahl, durch Fräsen und Drehen, Laserschneiden / 3D-Laser, Faltpressen bearbeitet.

Acero laminado y estirado, fresado y torneado, corte láser / láser 3D, plegado a presión.



## 12% HPL

Pannelli compositi costituiti al 80% da cellulosa di riciclo + resine termoindurenti, certificate "GREENGUARD Indoor Air Quality".

Panels, 80% of which consist of recycled cellulose + thermosetting resins, certified "GREENGUARD Indoor Air Quality".

Panneaux composites composés à 80 % de cellulose recyclée + résines thermosensibles, certifiés « GREENGUARD Indoor Air Quality ».

Verbundplatten bestehend zu 80% aus recyceltem Zellstoff + härtbaren Harzen, „GREENGUARD Indoor Air Quality“ zertifiziert.

Paneles compuestos de 80% de celulosa reciclada + resinas termoestables, certificadas "GREENGUARD Indoor AirQuality".

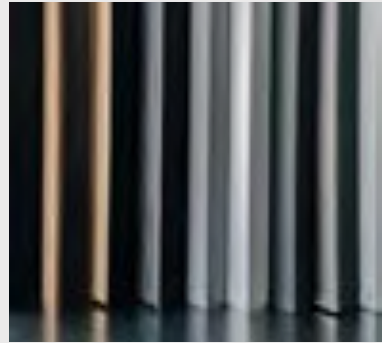

## 16% MDF / truciolare • MDF / chipboard

Pannelli costituiti da fibre di legno derivanti da sfrido di lavorazioni o residui di potature.

Panels made of wood fibres deriving from processing scraps or clippings.

Panneaux en fibres de bois provenant de chutes de traitement ou de résidus d'élagage.

Platten aus Holzfasern aus Bearbeitungsabfall oder Stützresten.

Paneles fabricados con fibras de madera procedentes de residuos de transformación o de poda.



## 5% Multistrato / Multilayer

Il pioppo e faggio Italiano sono essenze facilmente rinnovabili (ciclo di crescita 7/10 anni).

Italian poplar and beechwood are easily renewable species (growth cycle 7/10 years).

Le peuplier et le hêtre italien sont des bois facilement renouvelables (cycle de croissance 7/10 ans).

Pappel- und Buchenholz sind leicht erneuerbare Holzarten (Wachstumszyklus 7/10 Jahre).

El álamo italiano y el haya son especies fácilmente renovables (ciclo de crecimiento de 7/10 años).



## 2% Ottone / Brass

Ottone laminato e trafilato, ha un'ottima resistenza alla corrosione, esso deriva da riciclo e può essere riciclato.

Rolled and drawn brass has excellent resistance to corrosion, is a product of recycling and can be recycled in turn.

Laiton laminé et étiré, présente une excellente résistance à la corrosion, est issu du recyclage et peut être recyclé.

Gezogener Walzmessing, es hat eine optimale Beständigkeit gegen Korrosion, recyceltes Material, das wiederum recycelt werden kann.

El latón laminado y estirado, tiene una excelente resistencia a la corrosión, procede del reciclado y puede ser reciclado.



## 2% Ceramica / Ceramic

Costituita da argille e sabbie, materie prime ampiamente diffuse e non a rischio di esaurimento.

Made from clay and sand, commonly found raw materials that are not at risk of depletion.

Constituée d'argiles et de sables, des matières premières largement répandues et non menacées d'épuisement.

Gebildet aus Ton und Sand, weit verbreiteten Rohstoffen, die kein Versiegen riskieren.

Se compone de arcillas y arenas, materias primas ampliamente disponibles y sin riesgo de agotamiento.



## 0.5% Tessuti / Fabrics

Utilizziamo lino, cotone e tecnofibre prodotte al 100% in Italia.

We use linen, cotton and synthetic fibres 100% made in Italy.

Nous utilisons du lin, du coton et des fibres techniques produits à 100 % en Italie.

Wir verwenden zu 100% in Italien hergestellte Leinen, Baumwolle und Kunstfasern.

Utilizamos lino, algodón y tecnofibras producidas al 100% en Italia.



## 0.3% Cuoio / Leather

Impieghiamo cuoio Toscano con concia al vegetale "in fossa", trattato con grassi vegetali.

We use Tuscan leather with "in pit" vegetable tanning, treated with vegetable fat.

Nous utilisons du cuir toscano au tannage végétal « en puits », traité avec des graisses végétales.

Wir verwenden toskanisches Leder mit pflanzlicher Gerbung „in Gerbgrube“, behandelt mit pflanzlichen Fetten.

Utilizamos cuero toscano de curtido vegetal "en fosa", tratado con grasas vegetales.



## 0.2% Laccature / Lacquers

L'acqua è il principale componente delle laccature, ed evapora nell'aria in fase di asciugatura.

Water is the main component of the lacquering process, and evaporates in the air during the drying stage.

L'eau est le composant principal des laques et s'évapore dans l'air durant le séchage.

Das Wasser ist die Hauptkomponente der Lackierungen und es verdunstet in der Trocknungsphase.

El agua es el principal componente de las lacas, y se evapora en el aire durante el secado.





# LIVING SYSTEMS

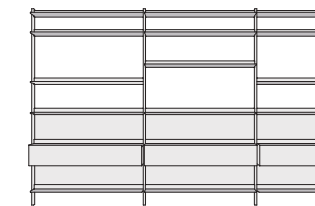

**EWS**  
extendo wall system

- |           |           |
|-----------|-----------|
| 05 pg. 30 | 03 pg. 36 |
| 04 pg. 32 | 06 pg. 40 |
| 02 pg. 34 | 01 pg. 44 |

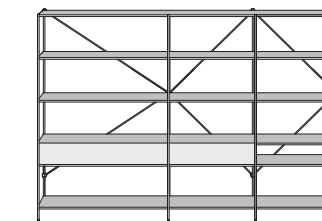

**XY**

- |            |            |
|------------|------------|
| 32 pg. 98  | 29 pg. 112 |
| 31 pg. 102 | 09 pg. 116 |
| 33 pg. 104 | 34 pg. 118 |
| 30 pg. 108 |            |

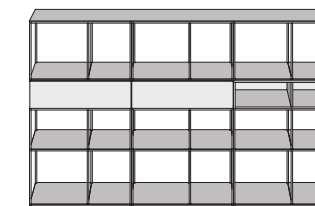

**ATELIER**

- |           |           |
|-----------|-----------|
| 09 pg. 50 | 10 pg. 64 |
| 02 pg. 52 | 13 pg. 66 |
| 04 pg. 54 | 05 pg. 68 |
| 01 pg. 56 | 06 pg. 70 |
| 12 pg. 58 | 07 pg. 72 |
| 03 pg. 60 | 08 pg. 73 |
| 11 pg. 62 |           |

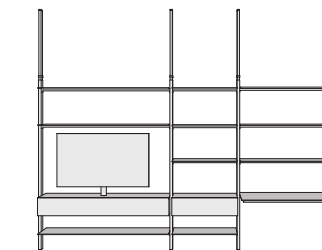

**SYSTEM**

- |            |            |
|------------|------------|
| 56 pg. 124 | 03 pg. 132 |
| 54 pg. 126 | 52 pg. 134 |
| 16 pg. 130 | 53 pg. 136 |
| 14 pg. 131 |            |

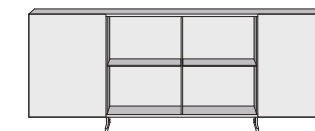

**MONOLITH**

- |           |            |
|-----------|------------|
| 11 pg. 78 | 06 pg. 88  |
| 09 pg. 80 | 02 pg. 89  |
| 04 pg. 84 | 02A pg. 90 |
| 10 pg. 86 | 05 pg. 92  |



# TABLES

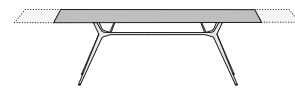

BALANCE fixed | extendable

10 pg. 144    06 pg. 152  
 08 pg. 146    05 pg. 154  
 09 pg. 148    07 pg. 156  
 04 pg. 150



IPE fixed

01 pg. 204  
 03 pg. 206  
 02 pg. 208

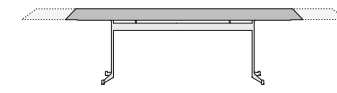

T9 fixed | extendable

04 pg. 236  
 02 pg. 238  
 03 pg. 240  
 01 pg. 242



MR.HYDE fixed | extendable

28 pg. 266  
 29 pg. 268

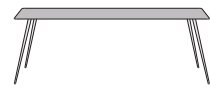

SPILLO fixed

28 pg. 160    21 pg. 167  
 24 pg. 162    25 pg. 168  
 04 pg. 164    22 pg. 170  
 05 pg. 166

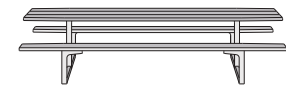

HAMMER fixed

04 pg. 212  
 05 pg. 214  
 06 pg. 216



T10 fixed

02 pg. 246  
 01 pg. 248



SPILLO fixed

26 pg. 172  
 27 pg. 173

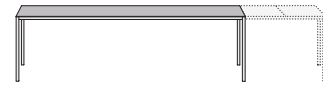

SINTESI fixed | extendable

01 pg. 176    04 pg. 184  
 02 pg. 178    05 pg. 185  
 03 pg. 180

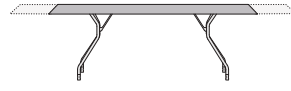

T7 fixed | extendable

03 pg. 220  
 01 pg. 222

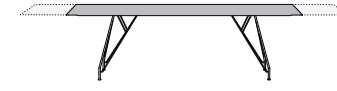

T11 fixed | extendable

03 pg. 252  
 02 pg. 254  
 01 pg. 256



DÉCO fixed

03 pg. 274    04 pg. 277  
 05 pg. 275    01 pg. 278  
 06 pg. 276    02 pg. 279



ST35 fixed | extendable

05 pg. 188    03 pg. 198  
 02 pg. 190    04 pg. 200  
 01 pg. 194

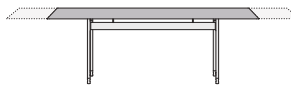

T8 fixed | extendable

05 pg. 226  
 01 pg. 228  
 04 pg. 230  
 02 pg. 232

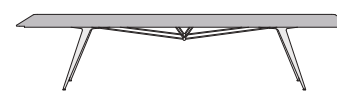

T12 fixed

01 pg. 260

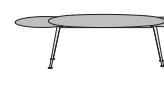

MR.HYDE fixed | extendable

02 pg. 270  
 09 pg. 271

## COFFEE TABLES

# SEATINGS



## DANISKE C

- 01 pg. 284
- 02 pg. 286
- 05 pg. 288
- 03 pg. 290
- 04 pg. 292



## VIKING

- 01 pg. 296
- 06 pg. 298
- 07 pg. 300
- 05 pg. 301



## ECH3

- 01 pg. 304
- 02 pg. 305
- 04 pg. 306
- 03 pg. 307



## ECH4

- 02 pg. 310
- 01 pg. 312
- 03 pg. 313



## ECH5

- 01 pg. 316
- 02 pg. 317



## ECH6

- 01 pg. 320
- 02 pg. 321
- 03 pg. 322
- 04 pg. 323



## ECH7

- 04 pg. 326
- 02 pg. 327
- 01 pg. 328
- 03 pg. 329

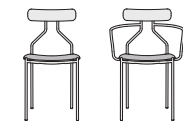

## ECH8

- 01 pg. 332
- 02 pg. 333

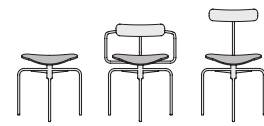

## ECH9

- 01 pg. 336
- 02 pg. 337

# LAMPS

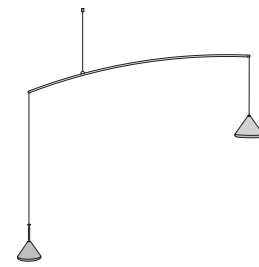

## CONTRAPPESO

- suspension
- 04 pg. 342

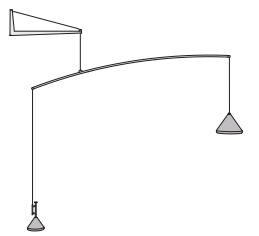

### wall

- 01 pg. 344

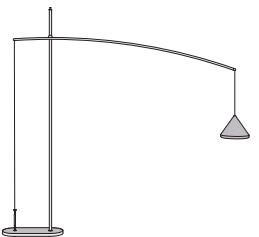

### floor

- 02 pg. 345
- 03 pg. 346
- 05 pg. 347

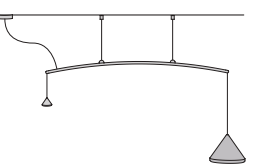

### ceiling

- 09 pg. 348
- 08 pg. 350
- 06 pg. 352
- 07 pg. 353

# MULTIMEDIA

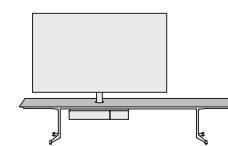

## CONNECT

tv dimension: 40" - 85"

- 01 pg. 358
- 02 pg. 362

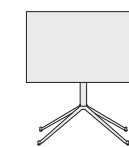

## APOLLO

tv dimension: 40" - 65"

- 02 pg. 366

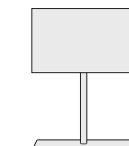

## SPIN 360

tv dimension: 40" - 65"

- 01 pg. 372

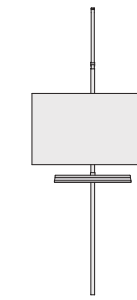

## SYSTEM MULTIMEDIA

tv dimension: 40" - 65"

- 55 pg. 378
- 23 pg. 380

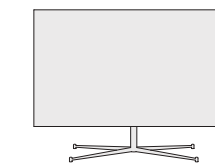

## TITANO

tv dimension: 55" - 85"

- 01 pg. 384
- 02 pg. 386

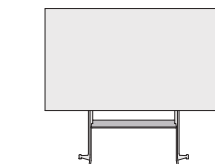

## URANO

tv dimension: 55" - 85"

- 01 pg. 390
- 02 pg. 392

# WALK-IN CLOSETS

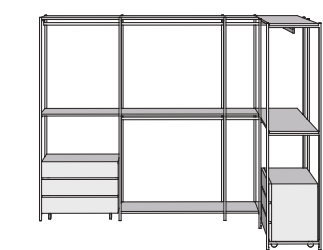

## SLIDE

- 01 pg. 400
- 04 pg. 404
- 03 pg. 408
- 02 pg. 410

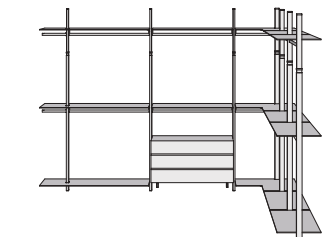

## PERSONAL

- 01 pg. 416
- 02 pg. 420
- 03 pg. 424
- 04 pg. 428
- 05 pg. 430

# EXTENDO DIGITAL LEARNING



- Come interagire
- How to interact
- Comment interagir
- Wie man interagiert
- Como interactuar

I QR CODE ALL'INTERNO DEL CATALOGO TI CONSENTIRANNO UN IMMEDIATO ACCESSO A DEI BREVI VIDEO DI APPROFONDIMENTO PER SCOPRIRE FUNZIONI DINAMICHE E CARATTERISTICHE TECNICHE DELLE COLLEZIONI EXTENDO.

The QR codes in the catalogue take you straight to short videos that present the dynamic functions and technical data of the Extendo collections.

Les codes QR du catalogue vous permettront d'accéder immédiatement à de courtes vidéos d'approfondissement pour découvrir les fonctions dynamiques et les caractéristiques techniques des collections Extendo.

Die QR-Codes im Katalog geben Ihnen sofortigen Zugriff auf kurze Videos, um die dynamischen Funktionen und die technischen Eigenschaften der Kollektionen von extendo zu entdecken und zu vertiefen.

Los códigos QR del catálogo le permitirán acceder inmediatamente a breves vídeos de profundización para descubrir las funciones dinámicas y las características técnicas de las colecciones Extendo.



# QR CODE INDEX

<b>PRODUCTION</b> • Our manufacturing process • Comment produisons-nous nos articles • Wie wir produzieren • Como producimos	pag. 7	<b>MONOLITH</b> • Scrittoio • Writing desk • Bureau • Schreibtisch • Escritorio	pag. 93	<b>BALANCE</b> • Apertura allunghe • Opening of extensions • Ouverture de rallonges • Öffnung verlängerungsstücke • Apertura de la extensión	pag. 145	<b>T8</b> • Apertura allunghe • Opening of extensions • Ouverture de rallonges • Öffnung verlängerungsstücke • Apertura de la extensión	pag. 227	<b>ECH3</b> • Caratteristiche costruttive • Construction characteristics • Caractéristiques de construction • Konstruktionsmerkmale • Características constructivas	pag. 305	<b>MULTIMEDIA</b>	
<b>DIGITAL LEARNING</b> • Come interagire • How to interact • Comment interagir • Wie man interagiert • Como interactuar	pag. 22	<b>XY</b> • PRODUCT CONCEPT	pag. 95	<b>SINTESI</b> • Apertura allunghe • Opening of extensions • Ouverture de rallonges • Öffnung verlängerungsstücke • Apertura de la extensión	pag. 177	<b>T9</b> • Apertura allunghe • Opening of extensions • Ouverture de rallonges • Öffnung verlängerungsstücke • Apertura de la extensión	pag. 237	<b>ECH4</b> • Caratteristiche costruttive • Construction characteristics • Caractéristiques de construction • Konstruktionsmerkmale • Características constructivas	pag. 311	<b>APOLLO</b> • Caratteristiche funzionali • Functional characteristics • Caractéristiques fonctionnelles • Funktionale merkmale • Características funcionales	pag. 367
		<b>XY</b> • Sistema brevettato • Patented system • Système breveté • Patentiertes system • Sistema patentado	pag. 99	<b>ST35</b> • Apertura allunghe • Opening of extensions • Ouverture de rallonges • Öffnung verlängerungsstücke • Apertura de la extensión	pag. 189	<b>T11</b> • Apertura allunghe • Opening of extensions • Ouverture de rallonges • Öffnung verlängerungsstücke • Apertura de la extensión	pag. 253	<b>ECH5</b> • Caratteristiche costruttive • Construction characteristics • Caractéristiques de construction • Konstruktionsmerkmale • Características constructivas	pag. 317	<b>SPIN360</b> • Caratteristiche funzionali • Functional characteristics • Caractéristiques fonctionnelles • Funktionale merkmale • Características funcionales	pag. 375
<b>LIVING SYSTEMS</b>		<b>XY</b> • Dettaglio anta • Detail of a door • Détail de la porte • Türdetail • Detalle de la puerta	pag. 105	<b>BENCHES</b> • Schienale flessibile • Flexible backrest • Dossier flexible • Flexible rückenlehne • Respaldo flexible	pag. 195	<b>T12</b> • Caratteristiche costruttive • Construction characteristics • Caractéristiques de construction • Konstruktionsmerkmale • Características constructivas	pag. 262	<b>ECH6</b> • Caratteristiche costruttive • Construction characteristics • Caractéristiques de construction • Konstruktionsmerkmale • Características constructivas	pag. 321	<b>SYSTEM MULTIMEDIA</b> • Caratteristiche funzionali • Functional characteristics • Caractéristiques fonctionnelles • Funktionale merkmale • Características funcionales	pag. 379
<b>EWS</b> • PRODUCT CONCEPT	pag. 27	<b>SYSTEM</b> • PRODUCT CONCEPT	pag. 121	<b>ST35</b> • Passacavi tavolo studio • Office desk cable sleeve • Passe-câbles pour table de bureau • Kabeldurchgang bürotisch • Pasacables mesa de trabajo	pag. 199	<b>MR. HYDE</b> • Rotazione allunghe • Rotation of extensions • Rotation des rallonges • Rotation verlängerungsstücke • Rotación de extensiones	pag. 267	<b>ECH7</b> • Caratteristiche costruttive • Construction characteristics • Caractéristiques de construction • Konstruktionsmerkmale • Características constructivas	pag. 327	<b>TITANO</b> • Caratteristiche funzionali • Functional characteristics • Caractéristiques fonctionnelles • Funktionale merkmale • Características funcionales	pag. 385
<b>EWS</b> • Dettaglio anta • Detail of a door • Détail de la porte • Türdetail • Detalle de la puerta	pag. 33	<b>SYSTEM</b> • Sistema brevettato • Patented system • Système breveté • Patentiertes system • Sistema patentado	pag. 125	<b>ST35</b> • Passacavi scrittoio • Writing desk cable sleeve • Passe-câbles pour bureau • Kabeldurchgang schreibtisch • Pasacables escritorio	pag. 201	<b>DANSKE C</b> • Caratteristiche costruttive • Construction characteristics • Caractéristiques de construction • Konstruktionsmerkmale • Características constructivas	pag. 287	<b>ECH8</b> • Caratteristiche costruttive • Construction characteristics • Caractéristiques de construction • Konstruktionsmerkmale • Características constructivas	pag. 333	<b>URANO</b> • Caratteristiche funzionali • Functional characteristics • Caractéristiques fonctionnelles • Funktionale merkmale • Características funcionales	pag. 393
<b>EWS</b> • Pannello boiserie • Boiserie panel • Panneau en boiserie • Tafelungsplatte • Panel boiserie	pag. 37	<b>SYSTEM</b> • Dettaglio anta • Detail of a door • Détail de la porte • Türdetail • Detalle de la puerta	pag. 135	<b>IPE</b> • Cavi nascosti • Hidden cables • Câbles cachés • Versteckte kabel • Cables escondidos	pag. 205	<b>VIKING K</b> • Caratteristiche costruttive • Construction characteristics • Caractéristiques de construction • Konstruktionsmerkmale • Características constructivas	pag. 297	<b>ECH9</b> • Caratteristiche costruttive • Construction characteristics • Caractéristiques de construction • Konstruktionsmerkmale • Características constructivas	pag. 337	<b>WALK IN CLOSETS</b>	
<b>ATELIER</b> • PRODUCT CONCEPT	pag. 47	<b>TABLES</b>		<b>T7</b> • Apertura allunghe • Opening of extensions • Ouverture de rallonges • Öffnung verlängerungsstücke • Apertura de la extensión	pag. 221	<b>VIKING W</b> • Caratteristiche costruttive • Construction characteristics • Caractéristiques de construction • Konstruktionsmerkmale • Características constructivas	pag. 301	<b>LAMPS</b>		<b>SLIDE</b> • PRODUCT CONCEPT	pag. 397
<b>ATELIER</b> • Dettaglio anta • Detail of a door • Détail de la porte • Türdetail • Detalle de la puerta	pag. 63	<b>TABLE TOPS</b> • Caratteristiche tecniche • Technical characteristics • Caractéristiques techniques • Technische merkmale • Características técnicas	pag. 140-141					<b>CONTRAPPESO</b> • Caratteristiche costruttive • Construction characteristics • Caractéristiques de construction • Konstruktionsmerkmale • Características constructivas	pag. 343	<b>PERSONAL</b> • Caratteristiche funzionali • Functional characteristics • Caractéristiques fonctionnelles • Funktionale merkmale • Características funcionales	pag. 413
<b>MONOLITH</b> • PRODUCT CONCEPT	pag. 75									<b>PERSONAL</b> • PRODUCT CONCEPT	pag. 417
<b>MONOLITH</b> • Caratteristiche costruttive • Construction characteristics • Caractéristiques de construction • Konstruktionsmerkmale • Características constructivas	pag. 87										

# LIVING SYSTEM

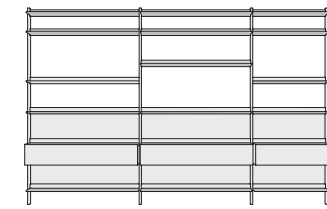

EWS  
extendo wall system  
pg. 26

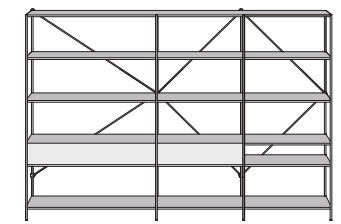

XY  
pg. 94

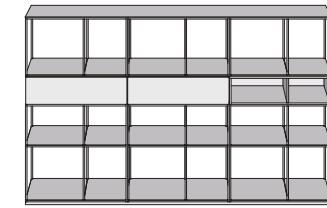

ATELIER  
pg. 46

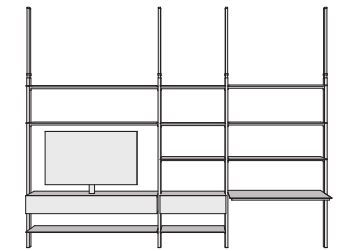

SYSTEM  
pg. 120

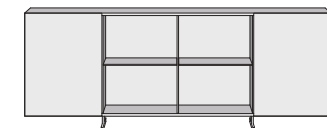

MONOLITH  
pg. 74

# EWS

extendo wall system

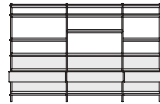

UN SISTEMA LIVING DALLE MOLTEPLICI  
POSSIBILITÀ DI INSTALLAZIONE: SOSPESO A  
PARETE, CON APPOGGIO A PAVIMENTO, DA  
PAVIMENTO A SOFFITTO ED AUTOPORTANTE.  
I PROFILI VERTICALI CONSENTONO IL  
POSIZIONAMENTO IN ALTEZZA DI CONTENITORI  
E RIPIANI AL CENTIMETRO. I PANNELLI  
DI RIVESTIMENTO UTILIZZATI ANCHE  
PARZIALMENTE POSSONO ESSERE RIMOSSI  
AGEVOLMENTE PER POTER ACCEDERE AI CAVI  
DI TV, IMPIANTI AUDIO, LAMPADE.

A living system with multiple installation possibilities: suspended on the wall, with or without floor support, floor standing, wall mounting and free standing. The vertical profiles permit positioning of containers and shelves to the centimetre. Any panels used can be easily removed to access TV, audio systems and lamp cables.

Un système pour salon avec de multiples possibilités d'installation : suspendu au mur, avec ou sans support au sol, du sol au plafond et autoporteur. Les profils verticaux permettent de positionner les conteneurs et les étagères en hauteur, au centimètre près. Les panneaux d'embellissement utilisés, même partiellement, peuvent être facilement retirés pour accéder aux câbles des téléviseurs, systèmes audios, lampes.

Ein Living-System mit zahlreichen Montage-Möglichkeiten: hängend an der Wand, sowohl mit als auch ohne Stütze auf dem Boden, vom Boden bis zur Decke und selbsttragend. Die vertikalen Profile ermöglichen die Positionierung auf den Zentimeter der Behälter und der Einlegeböden. Die auch zum Teil verwendeten Überzugplatten können leicht entfernt werden, um zu den Kabeln von TV, Audioanlagen, Lampen zu greifen.

Un sistema con múltiples posibilidades de instalación: colgado en la pared, con o sin soporte en el suelo, de suelo a techo y autónomo. Los perfiles verticales permiten posicionar en altura los contenedores y las estanterías con una precisión de un centímetro. Los paneles de recubrimiento utilizados parcial o totalmente pueden retirarse fácilmente para acceder a los cables de la televisión, los sistemas de audio y las lámparas.

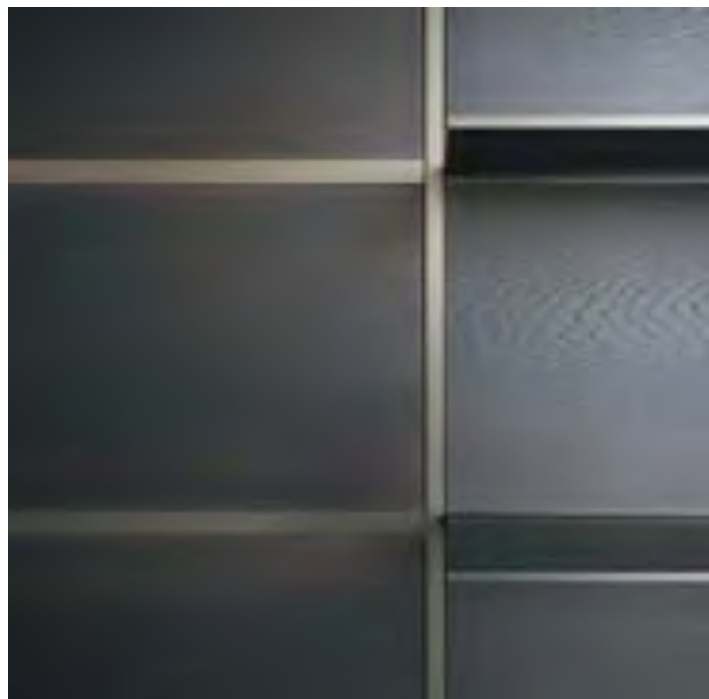

## PRODUCT CONCEPT

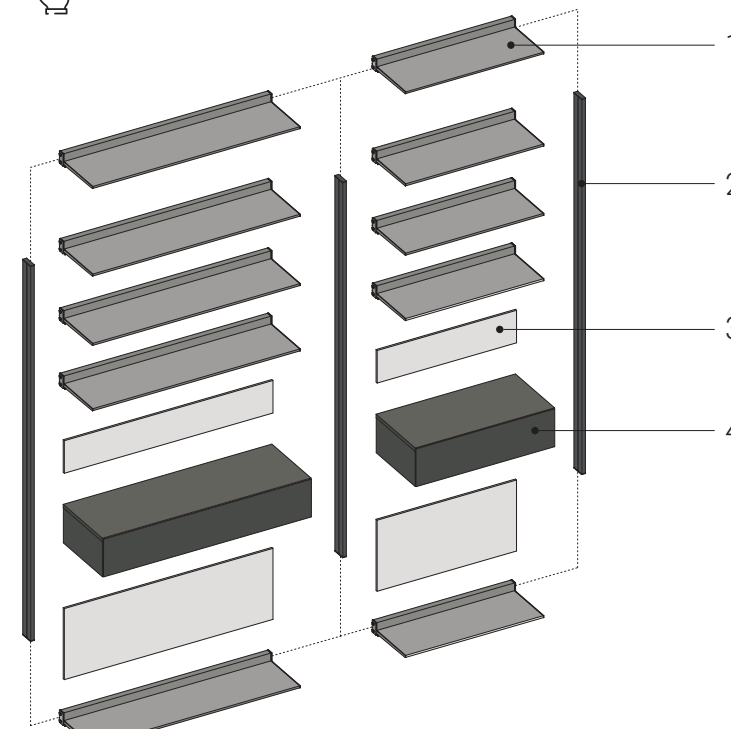

L modules  
36 - 72.5 - 108.5 - 144.5

H modules  
riducibile al centimetro  
reducible to the centimetre  
réductible au centimètre  
verkürzbar auf den  
Zentimeter  
reducible al centimetro

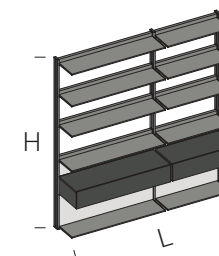

Ripiani e contenitori hanno libera posizione in altezza, (al centimetro).

Shelves and containers can be positioned at any height (to the centimetre).

Les étagères et les conteneurs peuvent être positionnés librement en hauteur (au centimètre près).

Einlegeböden und Behälter sind in der Höhe frei einsetzbar (auf den Zentimeter).

Los estantes y contenedores tienen una altura libre (al centimetro).



Sospeso a parete  
Wall suspended  
Suspendu au mur  
An der Wand hängend  
Montado en la pared



Pavimento / parete  
Floor / wall  
Sol/mur  
Boden / Wand  
Suelo / pared

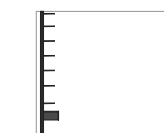

Pavimento / soffitto  
Floor / ceiling  
Sol/plafond  
Boden / Decke  
Suelo/techo

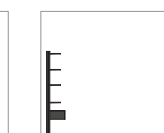

Appoggio a pavimento  
Floor standing  
Appui au sol  
Auf den Boden stützend  
Apoyado al suelo



Riduzioni a misura disponibili su profili verticali, ripiani e pannelli rivestimento.  
Measurement reductions available on vertical profiles, shelves and panels.

Réductions sur mesure possibles sur les profils verticaux, les étagères et les panneaux de revêtement.

Verkürzung nach Kundenwunsch auf vertikalen Profilen, Einlegeböden und Verkleidungsplatten.  
Las reducciones de tamaño son posibles en los perfiles verticales, las repisas y los paneles de revestimiento.



Passacavi disponibili su pannelli rivestimento e contenitori  
Cable sleeves available on panels and containers

Passe-câbles disponibles sur les panneaux de revêtement et les conteneurs.  
Kabeldurchgänge auf Verkleidungsplatten und Behälter verfügbar

Pasacables disponibles en los paneles de revestimiento y en los contenedores



Barre LED integrate ai pannelli rivestimento  
LED light bars incorporated in the panels

Barres LED incorporées dans les panneaux de revêtement  
In den Verkleidungsplatten integrierte LED-Stangen  
Barras de LED integradas en los paneles de revestimiento



1

I ripiani in alluminio estruso sono stati progettati in ogni minimo dettaglio per ottenere le massime performance di resistenza al carico con il minimo impiego di materiale.

Each and every detail of the extruded aluminium shelves has been designed to achieve maximum load resistance with the minimum amount of material.

Les étagères en aluminium extrudé ont été conçues dans les moindres détails pour obtenir des performances de résistance à la charge maximum en utilisant le moins de matériau possible.

Die Einlegeböden aus extrudiertem Aluminium wurden in jedem kleinsten Detail entworfen, um die höchste Belastbarkeit bei der niedrigsten Menge an verwendetem Material zu erhalten.

Los estantes de aluminio extruido se han diseñado hasta el más mínimo detalle para lograr el máximo rendimiento de carga con el mínimo uso de material.

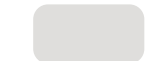

3

I pannelli schiena in MDF, disponibili in essenza e laccato, consentono il rivestimento della composizione parzialmente o totalmente, arricchendo la parete ed occultando eventuali cavi elettrici.

The MDF back panels, available in wood or lacquered, allow partial or total backing of the compositions, decorating the wall and hiding cables and wires.

Les panneaux de fond en MDF, disponibles en bois et laqués, permettent de recouvrir partiellement ou totalement la composition, en enrichissant le meuble et en dissimulant les câbles électriques.

Die Rückenplatten aus MDF sind aus Holznachbildung und lackiert verfügbar und ermöglichen die komplette oder teilweise Verkleidung der Komposition und bereichern so die Wand und verstecken eventuelle Stromkabel.

Los paneles traseros de MDF, disponibles en madera y lacados, permiten cubrir parcial o totalmente la composición, enriqueciendo la pared y ocultando los cables eléctricos.



2

I profili verticali in alluminio estruso, sono configurabili per adattarsi alle diverse esigenze degli ambienti. Sono infatti possibili configurazioni per l'installazione a parete, pavimento, soffitto e autoportante.

The vertical extruded aluminium profiles are modular, to adapt to the spaces. Indeed, they can be wall, floor or ceiling mounted or self-standing.

Les profils verticaux en aluminium extrudé peuvent être configurés pour s'adapter aux différents besoins des espaces. Des configurations pour une installation au mur, au sol, au plafond et autoportante sont ainsi possibles.

Die Vertikalen Profile aus extrudiertem Aluminium sind gestaltbar, um sich an die verschiedenen Anforderungen der Räume anzupassen. Es sind nämlich Konfigurationen für die Montage an der Wand, auf dem Boden, an der Decke und selbsttragende Konfigurationen möglich.

Los perfiles verticales de aluminio extruido pueden configurarse para adaptarse a los diferentes requisitos de los entornos. Las configuraciones son posibles para la instalación en la pared, en el suelo, en el techo y de forma independiente.



4

I contenitori, disponibili in essenza e laccato, sono configurabili con frontali in HPL o vetro temprato, di soli 4mm di spessore. La semplificazione delle geometrie rende il volume compatto e raffinato.

The containers, available in wood and lacquered, can have HPL or tempered glass fronts with a thickness of just 4 mm. The simplicity of the geometries makes the unit compact and elegant.

Les conteneurs, disponibles en bois et laqués, peuvent être configurés avec des façades en HPL ou en verre trempé de seulement 4 mm d'épaisseur. La simplification des géométries rend le volume compact et épuré.

Die Behälter sind aus Holznachbildung oder lackiert verfügbar und sind mit der Stirnseite aus HPL oder Hartglas mit einer Stärke von nur 4 mm konfigurierbar. Die Vereinfachung der Formen machen das Volumen kompakt und raffiniert.

Los contenedores, disponibles en madera y lacados, pueden configurarse con frentes de HPL o de vidrio templado, de sólo 4 mm de grosor. La simplificación de las geometrías hace que el volumen sea compacto y refinado.

## FINITURE/FINISHES

⚠ verificare a listino dimensioni e finiture  
check dimensions and finishes in the price list

### profilo ews / ews profile

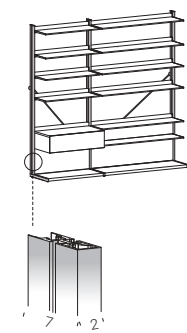

alluminio verniciato  
painted aluminium



## DIMENSIONI/DIMENSIONS

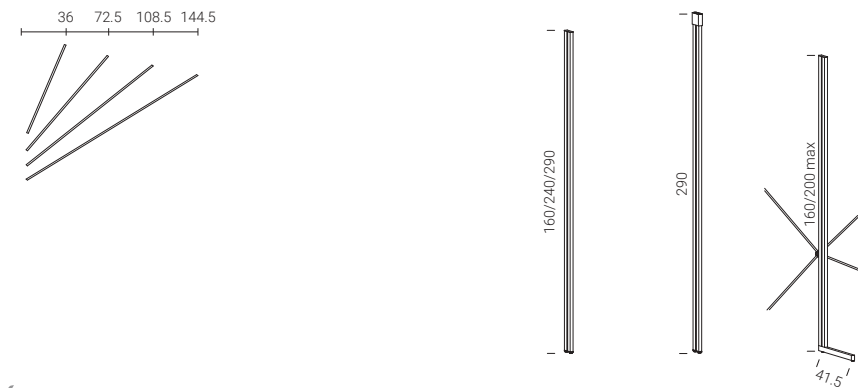

✂ cm disponibili riduzioni a misura / tailor-made reduction available

### ripiani e accessori / shelves and accessories

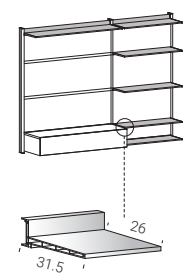

alluminio verniciato  
painted aluminium

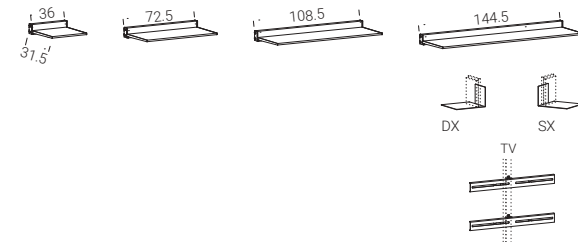

✂ cm disponibili riduzioni a misura / tailor-made reduction available

### contenitori / cabinets

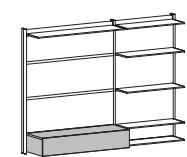

laccato  
lacquered



essenze  
woods



laccato metallo  
metal lacquer

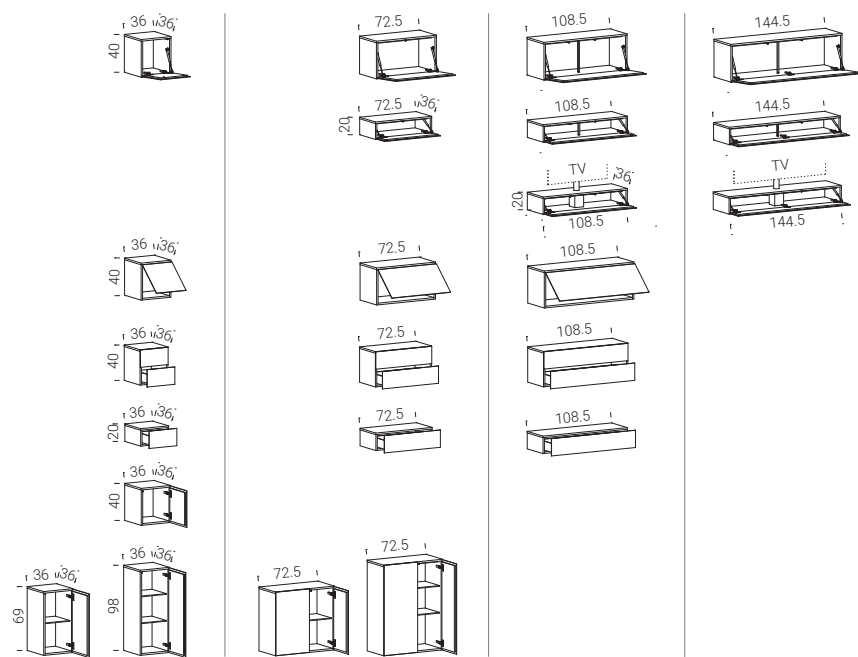

## FINITURE/FINISHES

⚠ verificare a listino dimensioni e finiture  
check dimensions and finishes in the price list

### pannello boiserie / boiserie panel

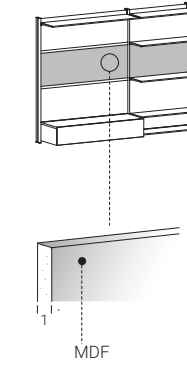

laccato  
lacquered



essenza  
wood

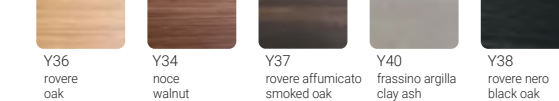

MDF

### top scrivania e boiserie / desktop and boiserie

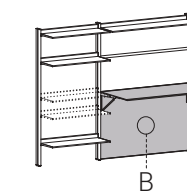

A POLARIS® / FENIX®

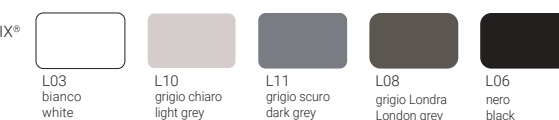

HPL + legno  
HPL + wood

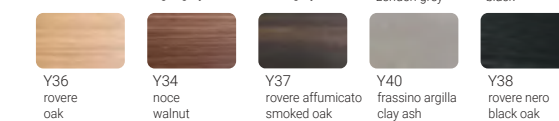

B laccato  
lacquered



essenza  
wood

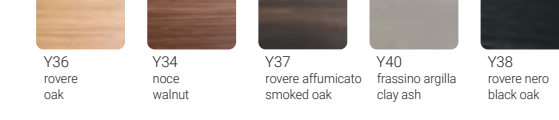

### ripiani a parete / wall shelves

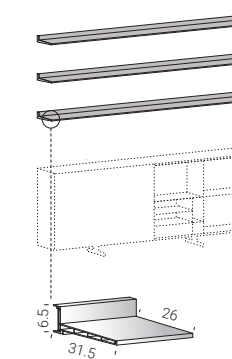

alluminio verniciato  
painted aluminium

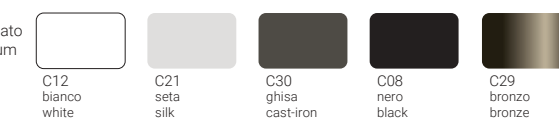

## DIMENSIONI/DIMENSIONS

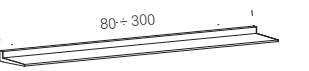
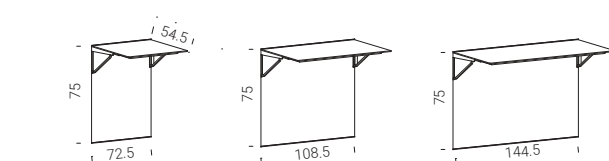
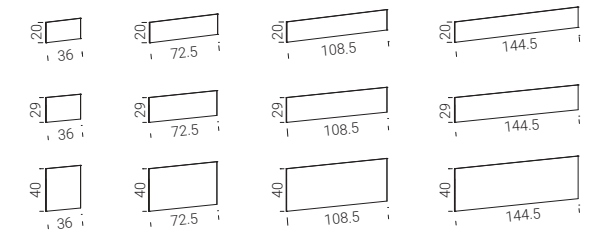

05/EWS

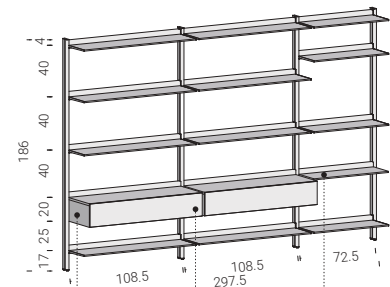

ECH4 pg. 308



T11 pg. 250

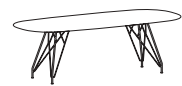



04/EWS

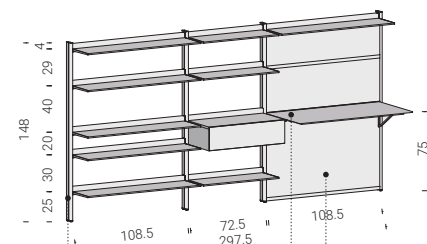

EWS

- Dettaglio anta
- Detail of a door
- Détail de la porte
- Türdetail
- Detalle de la puerta



02/EWS

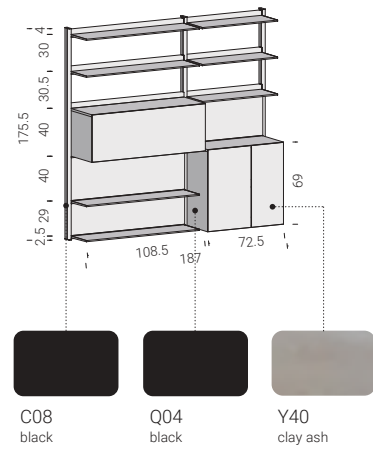

T7 pg. 218



CONTRAPPESO pg. 340

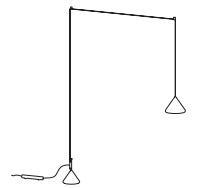

03/EWS

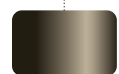
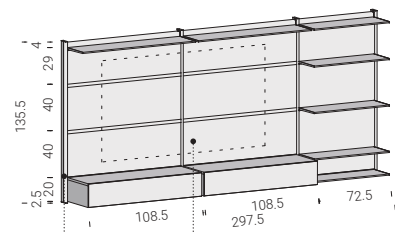

C29  
bronze



Y37  
smoked oak



EWS

- ▶ Pannello boiserie
- ▶ Boiserie panel
- ▶ Panneau en boiserie
- ▶ Tafelungsplatte
- ▶ Panel boiserie





06/EWS

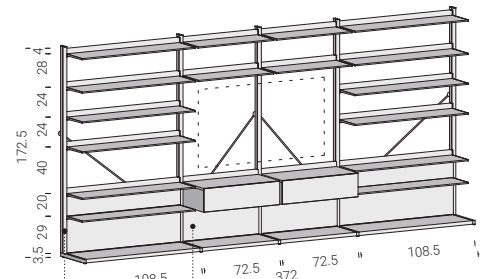

C30  
cast-iron



Y37  
smoked oak





01/EWS

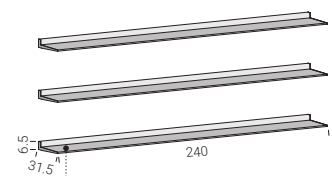

C30  
cast-iron

ECH4 pg. 308



MONOLITH pg. 74

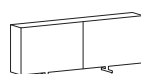

# ATELIER

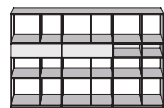

ATELIER È CONFIGURABILE UTILIZZANDO MODULI IN ACCIAIO CON SEZIONE MINIMA DI 10X10MM E CONTENITORI IN LEGNO CON DIVERSE TIPOLOGIE DI APERTURE. TELAI E CONTENITORI POSSONO ESSERE SOVRAPPOSTI E AFFIANCATI A PIACIMENTO, POSIZIONATI SU BASI O SOSPESI A PARETE. SONO DISPONIBILI ACCESSORI DA INSERIRE ALL'INTERNO DEI TELAI E TOP IN HPL O CERAMICA.



Atelier can be configured using modular elements in steel with a minimum 10x10mm cross-section as well as wooden containers with several different types of openings. Both frames and containers can be stacked and placed side by side as desired, either installed onto support bases or wall-mounted. Accessories to be integrated into the frames and tops in HPL or ceramic.

Atelier peut être configuré en utilisant des modules en acier avec une section minimum de 10x10 mm et des bacs en bois avec plusieurs typologies d'ouvertures. Châssis et bacs peuvent être superposés et associés à loisir, positionnés sur des bases ou suspendus au mur. Des accessoires sont disponibles pour l'insertion à l'intérieur des châssis et plateau en HPL ou céramique.

Bei der modularen Serie Atelier lassen sich Stahlmodule mit einer Mindeststärke von 10x10 mm mit Holzbehältern verschiedener Arten und Öffnungen kombinieren. Gestelle und Behälter können übereinander oder nebeneinander angeordnet, auf einen Unterbau gestellt oder an der Wand aufgehängt werden. Verschiedene Einsätze für die Gestelle sowie Abschlussplatten aus HPL oder Ceramic als Zubehör erhältlich.

Atelier se puede configurar utilizando módulos de acero con sección mínima de 10x10mm, así como contenedores de madera con distintos tipos de aperturas. Bastidores y contenedores, pueden colocarse uno encima del otro o uno al lado del otro, según se prefiera, posicionados sobre bases o colgados en la pared. Están disponibles accesorios que se pueden introducir en el interior de los bastidores y encimeras de laminado de alta presión (HPL) o cerámico.

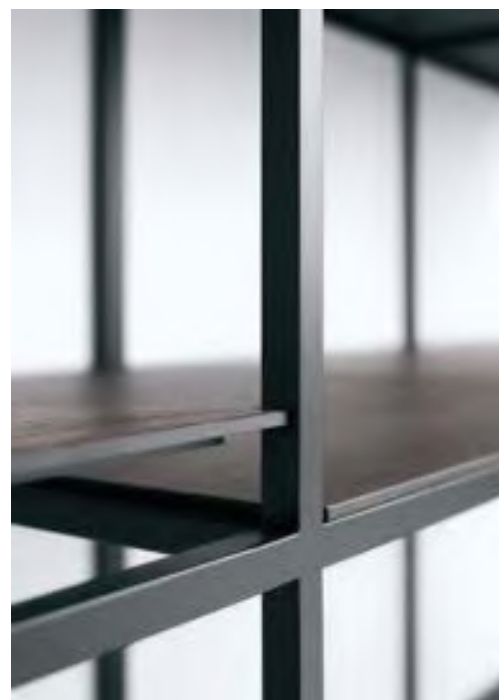

## PRODUCT CONCEPT

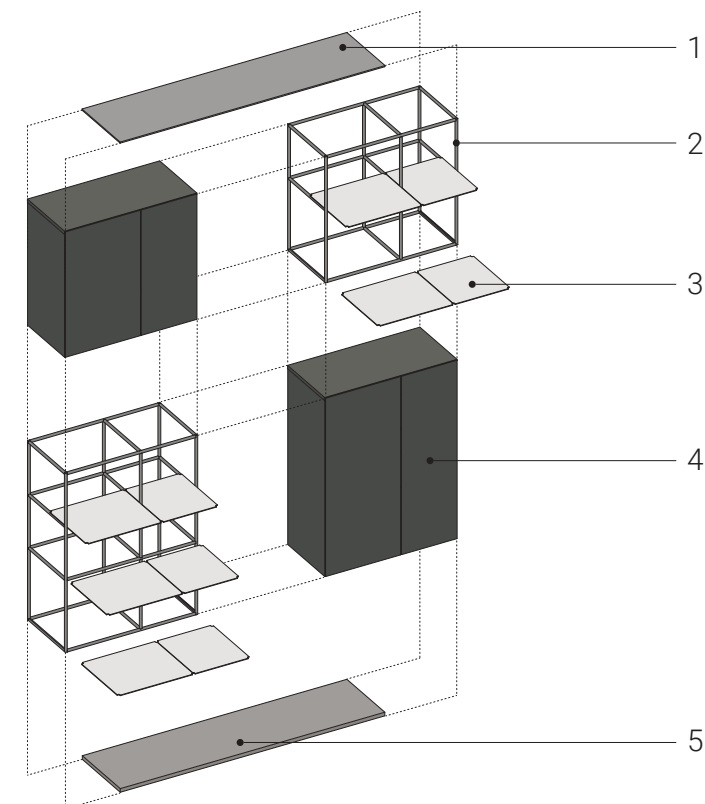

L modules  
36 - 72.5 - 108.5

H modules  
20 - 29 - 40 - 68 - 98

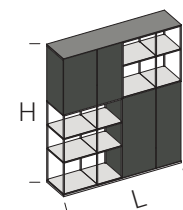

I moduli si affiancano e sovrappongono liberamente.  
The modules can be positioned side-by-side or overlapped as desired.  
Les modules se positionnent les uns à côté des autres et se superposent librement.  
Die Module können nebeneinander und übereinander frei montiert werden.  
Los módulos pueden colocarse uno al lado del otro y superponerse libremente.

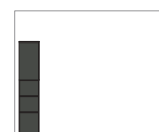

Pavimento / parete  
Floor / wall  
Sol / mur  
Boden / Wand  
Suelo / pared

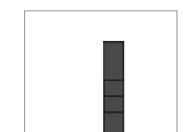

Bifacciale  
Double-sided  
Double face  
Zweiseitig  
Doble cara



Sospeso a parete  
Suspended on the wall  
Suspendu au mur  
An der Wand hängend  
Montado en la pared



Passacavi disponibili su contenitori  
Cable sleeves available on containers  
Des passe-câbles sont disponibles sur les conteneurs  
Kabeldurchgänge auf Behälter verfügbar  
Pasacables disponibles sobre los contenedores



Il top di spessore 6mm è disponibile in molteplici finiture e raggruppa al di sotto i diversi moduli affiancati, rendendo visivamente compatta l'intera composizione.

The 6 mm thick top is available in many finishes with various side-by-side modules underneath, creating a visually compact composition.

Le plateau de 6 mm d'épaisseur est disponible en plusieurs finitions et regroupe, directement en dessous, les différents modules positionnés côte à côte, pour une composition visuellement compacte.

Das 6 mm dicke Abschlussbord ist in zahlreichen Beschichtungen verfügbar und vereint unter sich die verschiedenen nebeneinander positionierten Module und macht so die gesamte Komposition visuell kompakt.

La encimera de 6 mm de grosor está disponible en varios acabados y agrupa los diferentes módulos uno al lado del otro por debajo, haciendo que toda la composición sea visualmente compacta.

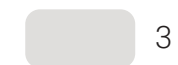

I ripiani interni ai moduli in acciaio sono in HPL. Disponibili nelle diverse varianti di finitura, vengono lavorati su tutto il perimetro per rendere minima e compatto l'accoppiamento con il modulo in acciaio.

The inside shelves of the steel modules are made of HPL. Available with a range of finishes that reach right to the edges and around the perimeter to make the coupling with the steel module minimal and compact.

Les étagères situées à l'intérieur des modules en acier sont en HPL. Elles sont disponibles en différentes variantes de finitions et sont travaillées sur tout leur périmètre pour permettre un accouplement minimal et compact avec le module en acier.

Die Einlegeböden innerhalb der Stahlmodule sind aus HPL. Sie sind in verschiedenen Beschichtungen verfügbar und werden auf dem gesamten Umfang bearbeitet, um die Verbindung mit dem Stahlmodul möglichst minimal und kompakt zu machen.

Los estantes del interior de los módulos de acero son de HPL. Disponibles en diferentes acabados, están mecanizados en todo su perímetro para que el acoplamiento con el módulo de acero sea mínimo y compacto.



I moduli in acciaio sono costituiti da barre a sezione piena 10x10 mm., predisposti per il fissaggio in sovrapposizione, affiancamento e per l'ancoraggio a parete. La finitura viene eseguita con verniciatura a polveri a 180°.

The steel modules are made of 10x10 mm full bars, designed for overlapping, side-by-side and wall fixing. 180° powder coating finish.

Les modules en acier sont constitués de barres de section pleine de 10x10 mm, conçues pour une fixation par superposition, côte à côte et un ancrage au mur. Les finitions sont réalisées par le biais d'un revêtement en poudre à 180°.

Die Stahlmodule bestehen aus massiven Stäben 10x10 mm, die übereinander, nebeneinander oder durch Verankerung an die Wand befestigt werden können. Die Beschichtung wird durch Pulverlackieren bei 180° ausgeführt.

Los módulos de acero están fabricados con barras de sección maciza de 10x10mm, preparadas para ser superpuestas, una al lado de la otra y fijadas a la pared. Están acabadas con un revestimiento de polvo a 180°.



I contenitori, disponibili in essenza e laccato, sono configurabili con frontali in HPL o vetro temprato, di soli 4mm di spessore. La semplificazione delle geometrie rende il volume compatto e raffinato.

The containers, available in wood and lacquered, can have HPL or tempered glass fronts with a thickness of just 4 mm. The simplicity of the geometries makes the unit compact and elegant.

Les conteneurs, disponibles en bois et laqués, peuvent être configurés avec des façades en HPL ou en verre trempé de seulement 4 mm d'épaisseur. La simplification des géométries rend le volume compact et élégant.

Die Behälter sind aus Holznachbildung oder lackiert verfügbar und sind mit der Stirnseite aus HPL oder Hartglas mit einer Stärke von nur 4 mm konfigurierbar. Die Vereinfachung der Formen machen das Volumen kompakt und raffiniert.

Los contenedores, disponibles en madera y lacados, pueden configurarse con frentes de HPL o de vidrio templado, de sólo 4 mm de grosor. La simplificación de las geometrías hace que el volumen sea compacto y refinado.



Le basi sono in multistrato laccato spessore 2cm. Le varianti con altezza 11 o 30cm sono sollevate da terra con un telaio in acciaio verniciato a polveri. Tutte le basi includono piedini di regolazione.

The multi-layer bases are 2 cm thick and lacquered. The versions with a height of 11 or 30 cm are raised above ground level on a powder coated steel frame. All of the bases include adjustment feet.

Les socles sont en contreplaqué laqué de 2 cm d'épaisseur. Les variantes de 11 ou 30 cm de hauteur sont surélevées par rapport au sol par le biais d'un cadre en acier peint par pulvérisation. Toutes les bases incluent des pieds de réglage.

Die Basiselemente sind aus lackiertem, 2 cm dickem Mehrschichtholz. Die Varianten mit Höhe 11 oder 30 cm sind durch ein pulverlackiertes Stahlgerüst vom Boden abgehoben. Alle Basiselemente sind inklusive Nivellierfüße.

Las bases son de madera contrachapada lacada de 2 cm de grosor. Las variantes de 11 o 30 cm de altura se levantan del suelo con un marco de acero con recubrimiento de polvo. Todas las bases incluyen pies ajustables.



## FINITURE/FINISHES

verificare a listino dimensioni e finiture  
check dimensions and finishes in the price list

### telaio / structure

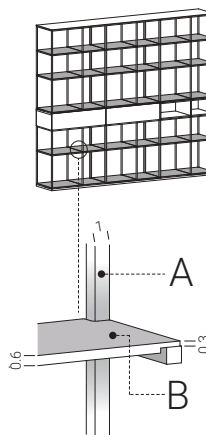

**A** acciaio verniciato painted steel

C12 bianco white	C21 seta silk	C23 corda ecru	C30 ghisa cast-iron	C14 antracite anthracite
C08 nero black	C29 bronzo bronze			

**B** POLARIS®

L03 bianco white	L10 grigio chiaro light grey	L11 grigio scuro dark grey
------------------	------------------------------	----------------------------

FENIX®

L08 grigio Londra London grey	L06 nero black
-------------------------------	----------------

HPL + legno HPL + wood

Y36 rovere oak	Y34 noce walnut	Y37 rovere affumicato smoked oak	Y40 frassino argilla clay ash	Y38 rovere nero black oak
----------------	-----------------	----------------------------------	-------------------------------	---------------------------

HPL laccato lacquered HPL

Q05 bianco white	Q16 seta silk	Q17 corda ecru	Q20 ghisa cast-iron	Q14 antracite anthracite
Q04 nero black	Q21 bronzo bronze			

### contenitori / cabinets

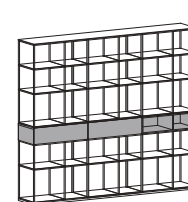

laccato lacquered

Q05 bianco white	Q16 seta silk	Q17 corda ecru	Q20 ghisa cast-iron	Q14 antracite anthracite
Q04 nero black	Q21 bronzo bronze			

essenze woods

Y36 rovere oak	Y34 noce walnut	Y37 rovere affumicato smoked oak	Y40 frassino argilla clay ash	Y38 rovere nero black oak
----------------	-----------------	----------------------------------	-------------------------------	---------------------------

laccato metallo metal lacquer

X01 rame copper	X02 ottone brass	X03 titanio titanium
-----------------	------------------	----------------------

## DIMENSIONI/DIMENSIONS

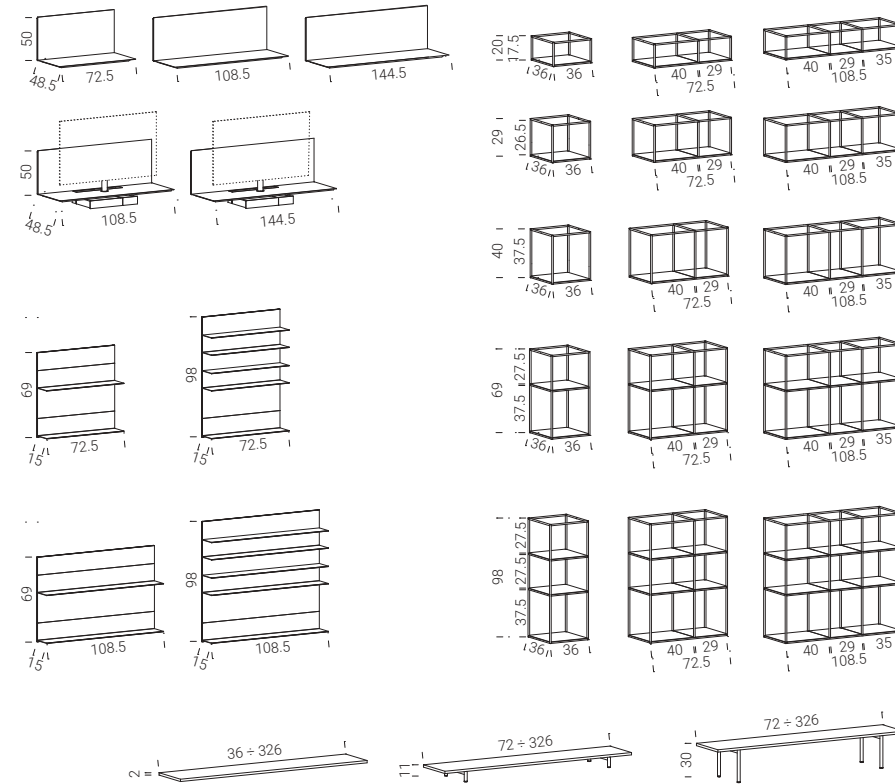

## FINITURE/FINISHES

verificare a listino dimensioni e finiture  
check dimensions and finishes in the price list

### moduli interni / internal modules

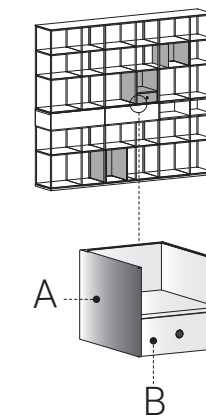

**A** acciaio verniciato painted steel

C12 bianco white	C21 seta silk	C23 corda ecru	C30 ghisa cast-iron	C14 antracite anthracite	C08 nero black	C29 bronzo bronze
------------------	---------------	----------------	---------------------	--------------------------	----------------	-------------------

**B** MDF laccato lacquered MDF

Q05 bianco white	Q16 seta silk	Q17 corda ecru	Q20 ghisa cast-iron	Q14 antracite anthracite	Q04 nero black	Q21 bronzo bronze
------------------	---------------	----------------	---------------------	--------------------------	----------------	-------------------

MDF legno MDF wood

Y37 rovere affumicato smoked oak	Y38 rovere nero black oak
----------------------------------	---------------------------

### top

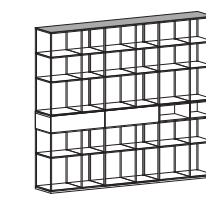

POLARIS® / FENIX®

L03 bianco white	L10 grigio chiaro light grey	L11 grigio scuro dark grey	L08 grigio Londra London grey	L06 nero black
------------------	------------------------------	----------------------------	-------------------------------	----------------

HPL + legno HPL + wood

Y36 rovere oak	Y34 noce walnut	Y37 rovere affumicato smoked oak	Y40 frassino argilla clay ash	Y38 rovere nero black oak
----------------	-----------------	----------------------------------	-------------------------------	---------------------------

HPL laccato lacquered HPL

Q16 seta silk	Q17 corda ecru	Q20 ghisa cast-iron	Q14 antracite anthracite	Q21 bronzo bronze
---------------	----------------	---------------------	--------------------------	-------------------

ceramica ceramic

S05 antracite anthracite	S06 nero black	S07 porfido porfido	S08 Cardoso Cardoso
--------------------------	----------------	---------------------	---------------------

## DIMENSIONI/DIMENSIONS

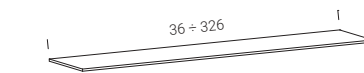
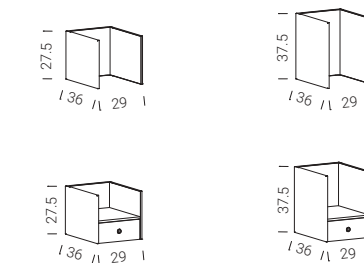

09/ATELIER

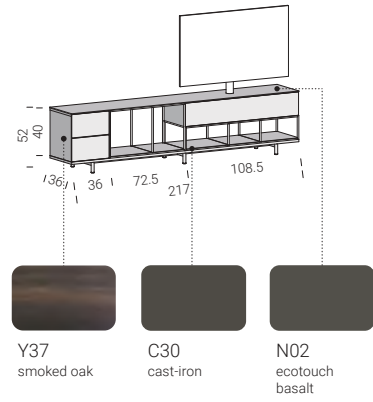

SPILLO pg. 172



CONTRAPPESO pg. 340

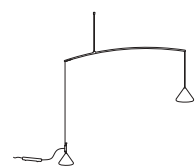

02/ATELIER

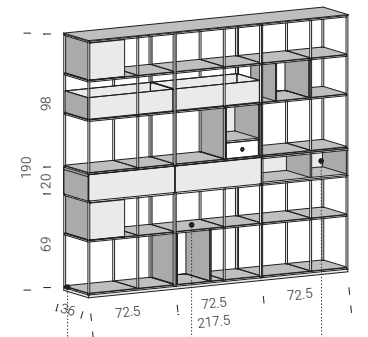

- C08 black
- Y38 black oak
- Q17 ecru

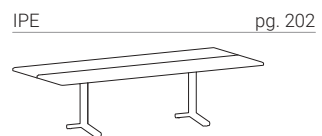

04/ATELIER

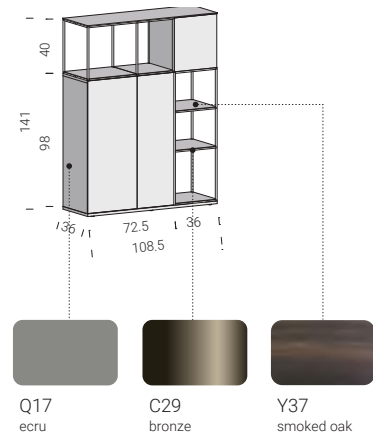

VIKING pg. 294



SPILLO pg. 172



BALANCE pg. 142



01/ATELIER

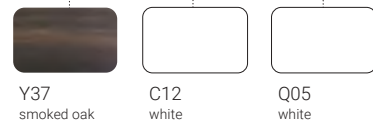
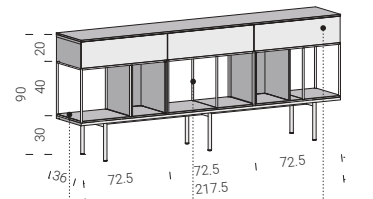

12/ATELIER

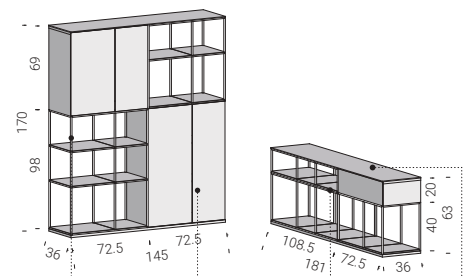

- C30 cast-iron
- Q20 cast-iron
- C08 black
- L06 FENIX® black

ECH4 pg. 308



ST35 pg. 186



CONTRAPPESO pg. 340

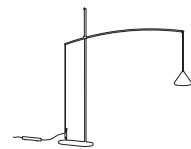

03/ATELIER

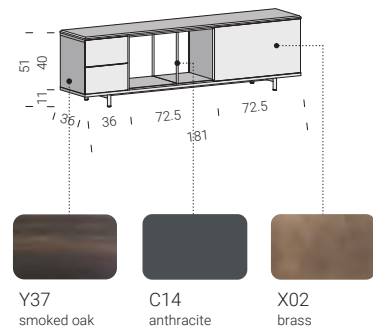

11/ATELIER

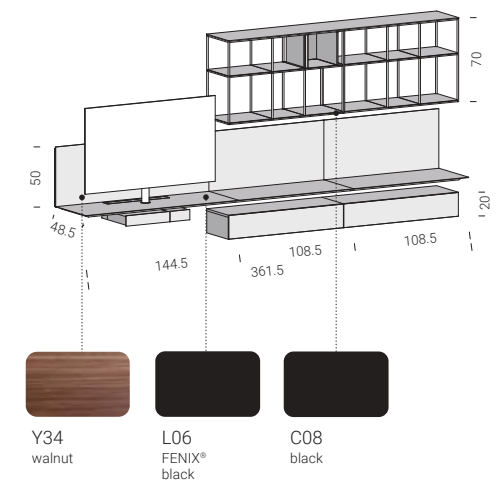

- ATELIER**
- ▶ Dettaglio anta
  - ▶ Detail of a door
  - ▶ Détail de la porte
  - ▶ Türdetail
  - ▶ Detalle de la puerta





10/ATELIER

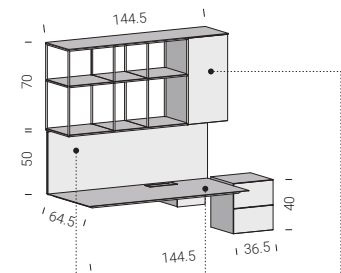

- Y37 smoked oak
- L06 FENIX® black
- Q04 black



13/ATELIER

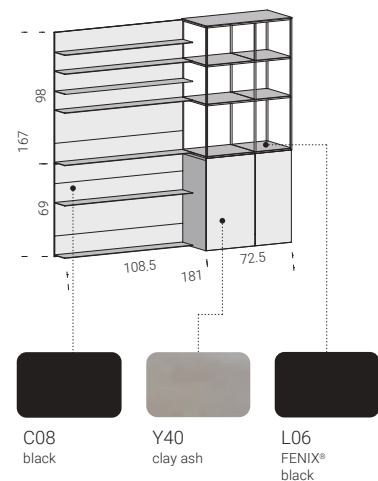

ECH5 pg. 314

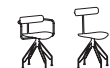

T7 pg. 218

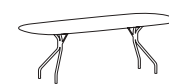

05/ATELIER

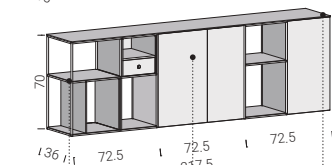
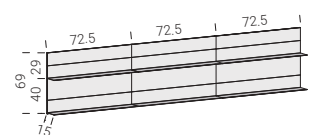

- C14 anthracite
- Q14 anthracite
- Y37 smoked oak



SPILLO pg. 172



T8 pg. 224

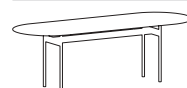

06/ATELIER

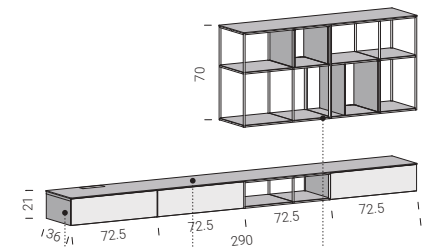

- Y37 smoked oak
- L06 FENIX® black
- C08 black



07/ATELIER

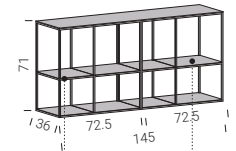

- C08 black
- L06 FENIX® black



08/ATELIER

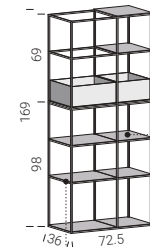

- C08 black
- L06 FENIX® black



# MONOLITH



LA SCOCCA IN ALLUMINIO ESTRUSO CHE COSTITUISCE L'OSSATURA PORTANTE DI MONOLITH, CONSENTE GRANDE RIGIDITÀ STRUTTURALE E UNA LIBERA CONFIGURAZIONE DELLE PARTIZIONI INTERNE. TALE SISTEMA COSTRUTTIVO FORMA UN INSIEME MOLTO SEMPLICE DA ASSEMBLARE E RICONFIGURARE, EVITANDO DI RADDOPPIARE GLI SPESSORI DEI FIANCHI AL SUO INTERNO.

The frame in extruded aluminium forming the support structure of Monolith gives an extremely firm structure with free configuration of the inner partitions. This composition system forms a very simple set to assemble and re-configure, without doubling the thicknesses of its inner sides.

Le châssis en aluminium extrudé qui constitue l'ossature portante de monolith, permet une grande rigidité structurelle et une libre configuration des divisions internes. Ce système de construction forme un ensemble très simple à assembler et reconfigurer, en évitant de doubler les épaisseurs des côtés à l'intérieur.

Der Aufbau aus extrudiertem Aluminium, der das tragenden Gerüst des monolith darstellt, bietet eine bedeutende, strukturelle Steifheit und eine freie Konfigurierung der Innenaufteilung. Dieses Konstruktionssystem bildet eine Einheit, die einfach zusammenzubauen und neu zu gestalten ist, wobei die Verdoppelung der Stärke der Seiten im Innenbereich vermieden wird.

El bastidor de aluminio extruido que constituye el armazón de soporte de Monolith permite una gran resistencia estructural y una libre configuración de las particiones interiores. Este sistema de construcción forma un conjunto muy fácil de montar y reconfigurar, evitando duplicar el espesor de los laterales en su interior.



## PRODUCT CONCEPT

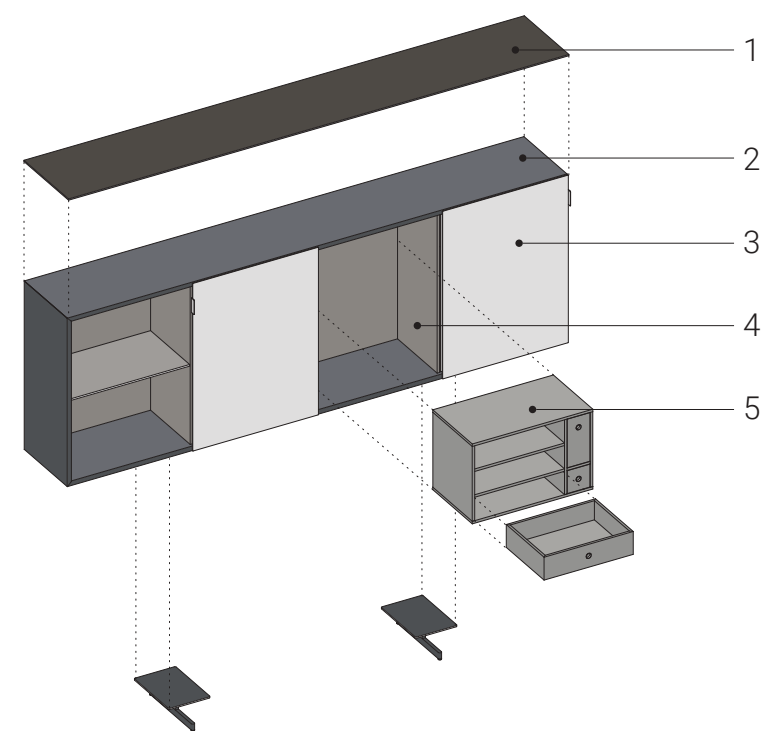

L modules  
121.6 - 181 - 240.4

H modules  
42.6 - 81 - 119.4 - 162

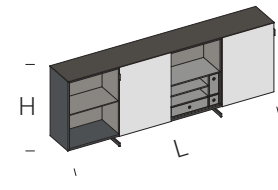

È possibile la sovrapposizione ed affiancamento dei moduli

The modules can be overlapped or side-by-side.

Les modules peuvent être superposés et placés les uns à côté des autres

Die Module können nebeneinander und übereinander montiert werden

Son posibles los módulos superpuestos y adosados.

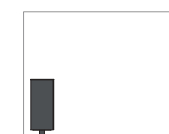

Pavimento / parete  
Floor / wall  
Sol / mur  
Boden / Wand  
Suelo / pared

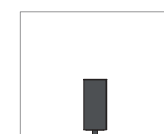

Centro stanza  
Room divider units  
Centre de la pièce  
Zimmermitte  
Centro de la habitación



Passacavi disponibili su pannello schiena e contenitori interni.  
Cable sleeves available on the back panel and internal containers  
Passe-câbles disponibles sur le panneau arrière et pour les conteneurs internes.  
Kabeldurchgänge auf Rückenplatte und inneren Behältern möglich.  
Pasacables disponibles en el panel trasero y en los contenedores internos.



Il top di spessore 6mm è disponibile in molteplici finiture, e protegge la superficie in alluminio della scocca ed il bordo dell'anta.

The 6 mm thick top is available in many finishes and protects the aluminium surface of the frame and the edge of the doors.

Le plateau de 6 mm d'épaisseur est disponible en plusieurs finitions et protège la surface en aluminium de la coque ainsi que le bord de la porte.

Das 6 mm dicke Abschlussbord ist in zahlreichen Beschichtungen verfügbar und schützt die Aluminiumoberfläche des Grundelements und den Türtrand.

La parte superior de 6 mm de grosor está disponible en varios acabados, y protege la superficie de aluminio del cuerpo y el borde de la puerta.



I frontali sono in vetro temprato di soli 4mm di spessore, disponibili nelle finiture laccato e laccato metallo. La semplificazione delle geometrie rende il volume delle madie compatto e raffinato.

The front panels are in 4 mm thick tempered glass, available in lacquered and metal lacquered finishes. The simplicity of the geometries makes the volume of the sideboards compact and elegant.

Les façades sont en verre trempé de seulement 4 mm d'épaisseur, disponibles dans les finitions laquées et laquées métal. La simplification des géométries permet aux buffets de présenter un volume compact et raffiné.

Die Stirnseiten sind aus nur 4 mm dickem Hartglas und sind in den Beschichtungen lackiert und metall-lackiert verfügbar. Die Vereinfachung der Formen machen das Volumen der Schrankkombinationen kompakt und raffiniert.

Los frentes son de vidrio templado de sólo 4 mm de espesor, disponibles en acabados lacado y lacado metálico. La simplificación de las geometrías hace que el volumen de los aparadores sea compacto y refinado.



La scocca perimetrale delle madie monolith è in alluminio estruso. La sezione d'estrusione è stata progettata in ogni minimo dettaglio per conferire rigidità e resistenza ai carichi con il minimo impiego di materiale.

The perimeter frame of the monolith sideboards is made of extruded aluminium. The extrusion section has been designed in detail to give it robustness and resistance to loads with a minimum use of material.

La coque de contour des buffets Monolith est en aluminium extrudé. La section d'extrusion a été conçue dans les moindres détails pour lui conférer rigidité et résistance aux charges en utilisant le moins de matériau possible.

Der Außenkorpus der Schrankkombinationen monolith ist aus extrudiertem Aluminium. Der Extrusionsschnitt wurde in jedem kleinsten Detail entworfen, um die höchste Festigkeit und Belastbarkeit bei der niedrigsten Menge an verwendetem Material zu erhalten.

El armazón perimetral de los aparadores Monolith es de aluminio extruido. La sección de extrusión ha sido diseñada en todos sus detalles para dar rigidez y resistencia a las cargas con el mínimo uso de material.



La monoscocca perimetrale in alluminio consente di non raddoppiare i fianchi interni in MDF, rendendo raffinato l'interno della madia anche con soluzioni a vista.

The aluminium perimeter single-frame means that the internal MDF sides do not have to be doubled, making the inside of the sideboard elegant, also with open compartment solutions.

La monocoque de contour en aluminium permet de ne pas doubler les panneaux latéraux internes en MDF, rendant l'intérieur du buffet raffiné également pour les solutions à vue.

Der selbsttragende Außenkorpus aus Aluminium ermöglicht es, die inneren Seiten aus MDF nicht zu verdoppeln und so ist die Schrankkombination auch mit offenen Lösungen raffiniert.

El monocasco perimetral de aluminio hace que los laterales internos de MDF no se dupliquen, haciendo que el interior del aparador sea refinado incluso con soluciones visibles.



Sono disponibili contenitori a più vani con cassetti interni in finitura laccato ed essenza, che possono essere posizionati all'interno della madia anche successivamente all'installazione.

Multi-compartment containers with internal drawers with lacquered and wood finishes, that can be positioned inside the sideboard also following installation, are available.

Des conteneurs à plusieurs compartiments avec tiroirs internes en finitions laquées et bois sont disponibles, avec possibilité de les placer à l'intérieur du buffet également après l'installation.

Es sind Behälter mit mehreren Fächern verfügbar, mit inneren Schubladen, lackiert und in Holznachbildung beschichtet, die auch nach der Montage in die Schrankkombination positioniert werden können.

Los contenedores con varios compartimentos están disponibles con cajones internos en acabados lacados y de madera, que pueden colocarse dentro del aparador incluso después de la instalación.

## FINITURE/FINISHES

### scocche / shells

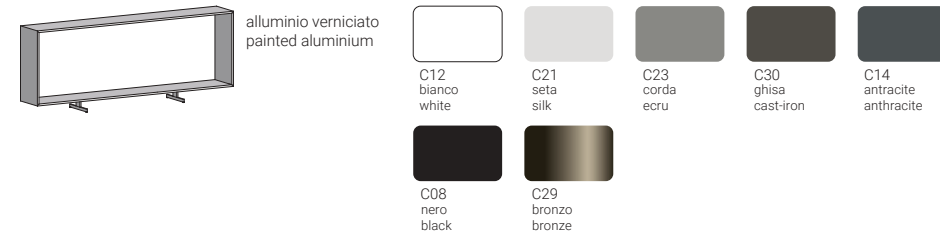

### fianchi interni / inner sides



### schiene / backs



### ripiani interni / inner shelving

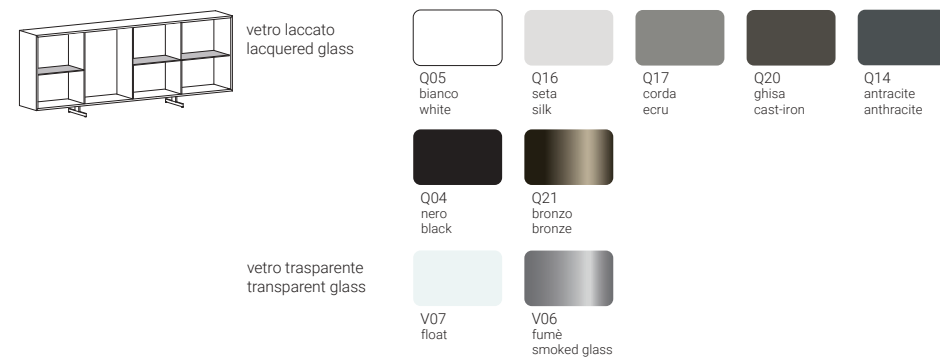

### frontali / doors fronts

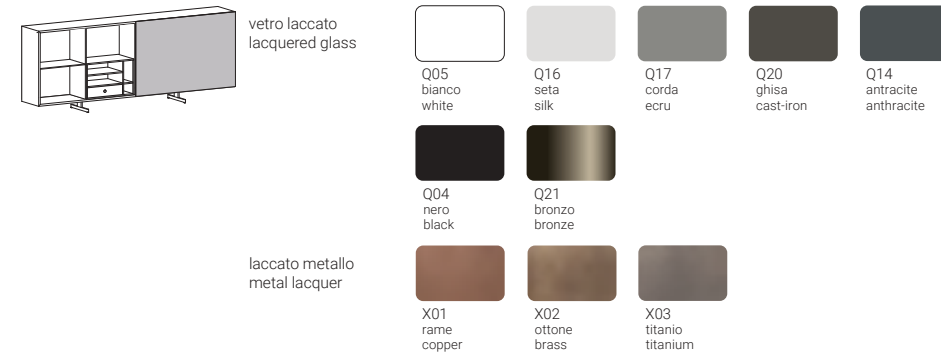

### top

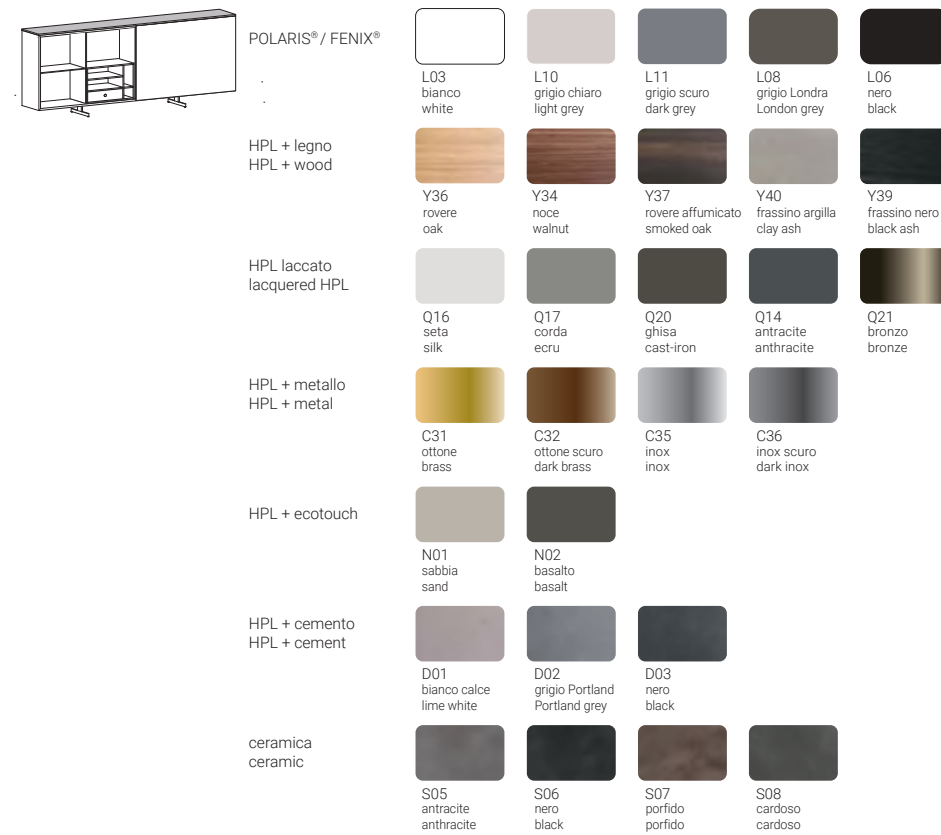

verificare a listino dimensioni e finiture  
check dimensions and finishes in the price list

## CONFIGURAZIONI / CONFIGURATIONS

### H1 = 42.6 cm

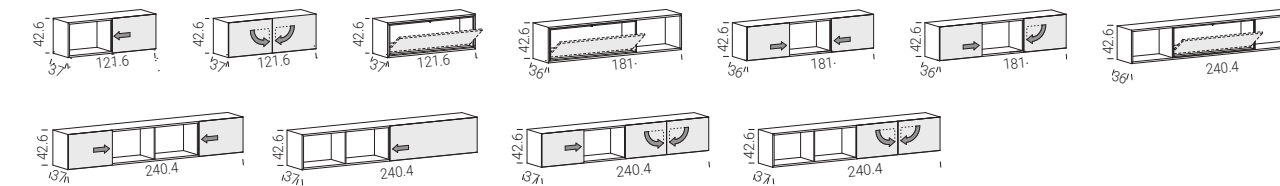

### H2 = 81 cm

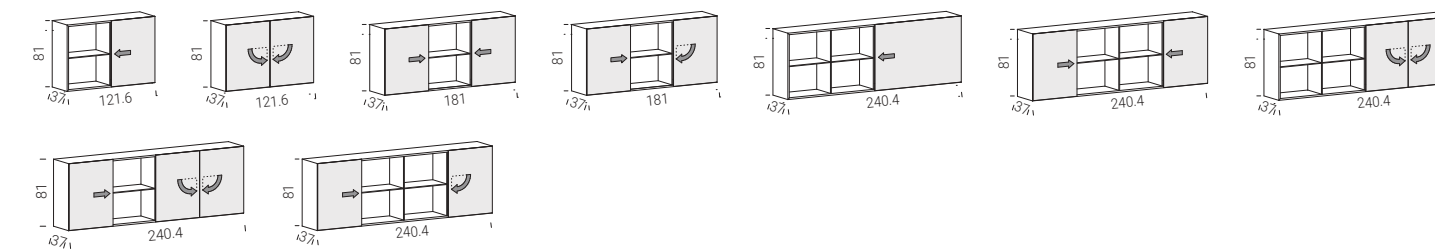

### H3 = 119.4 cm

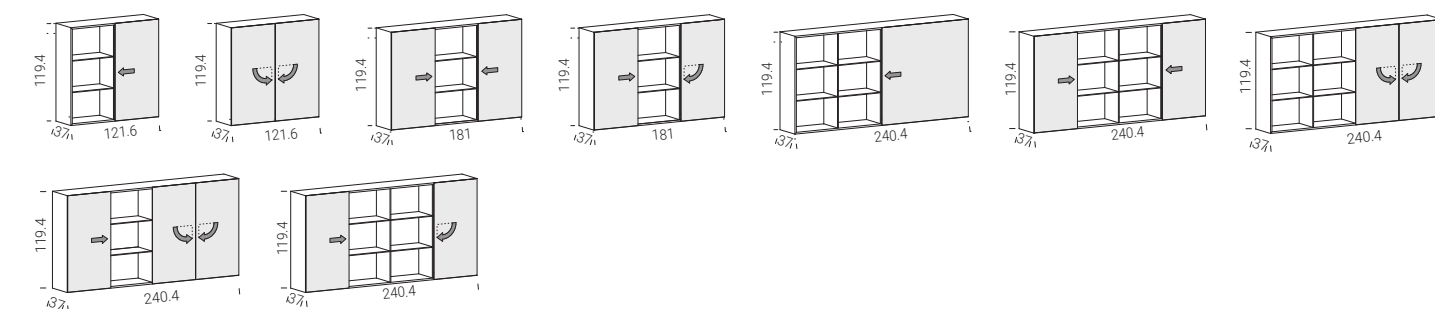

### H4 = 162 cm

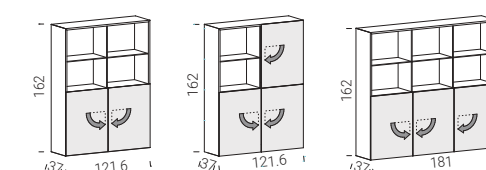

disponibili a listino ulteriori composizioni  
further compositions available per pricelist

verificare a listino dimensioni e finiture  
check dimensions and finishes in the price list

### accessori / accessories

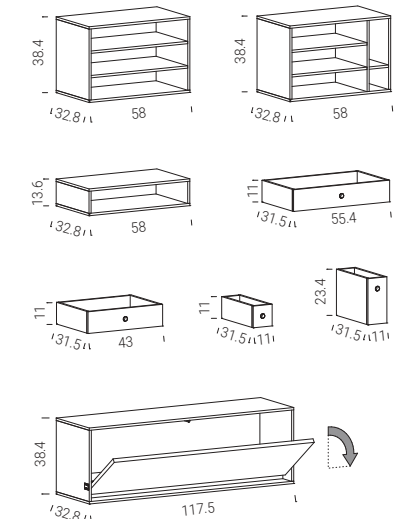

### basi / bases

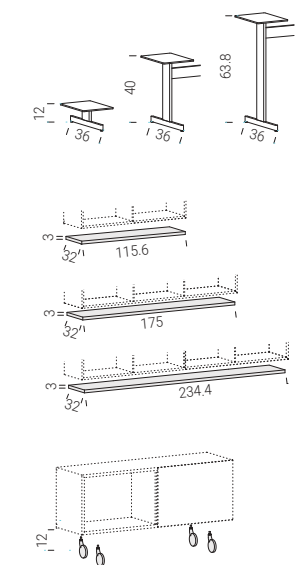

11/MONOLITH

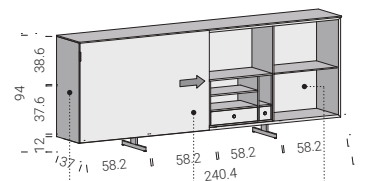

- C30 cast-iron
- X03 titanium
- Y34 walnut

EWS pg. 26



ECH4 pg. 308



CONTRAPPESO pg. 340

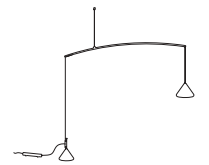



09/MONOLITH

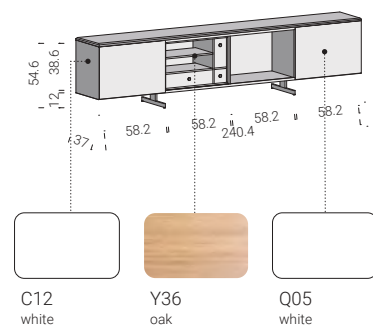

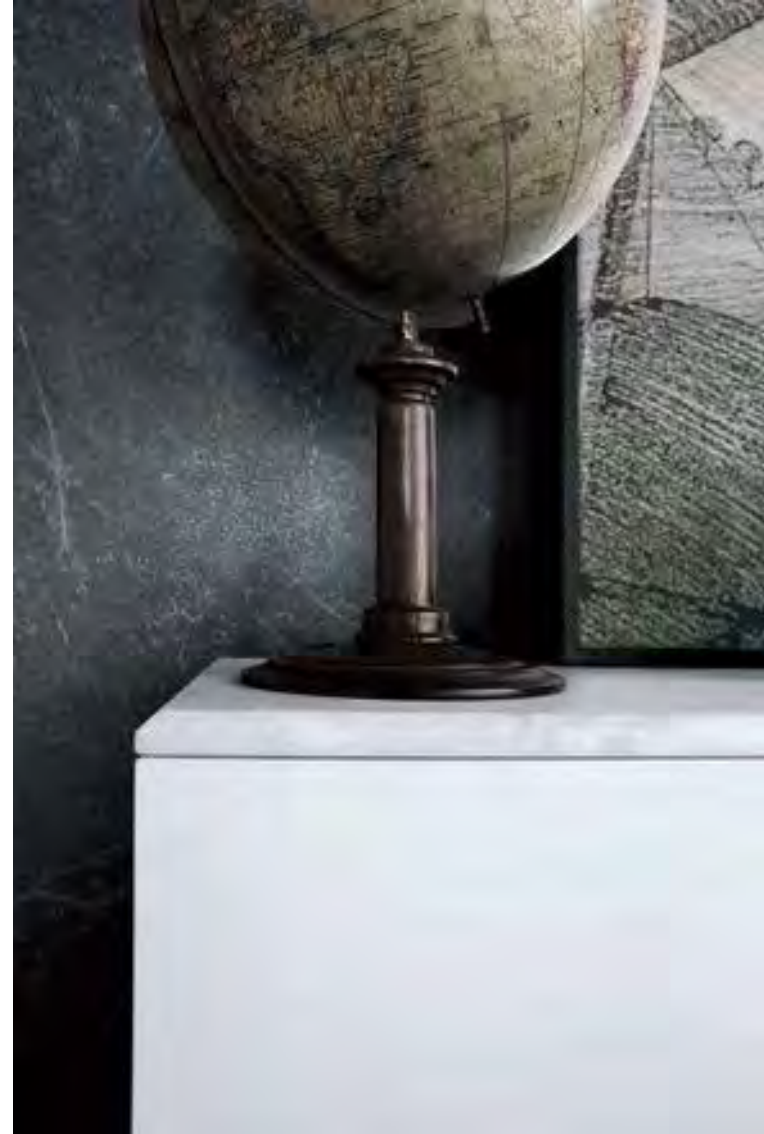

04/MONOLITH

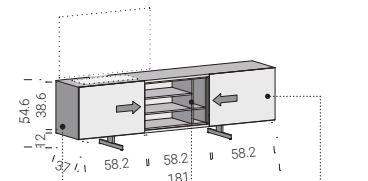

- C14 anthracite
- Y34 walnut
- Q14 anthracite

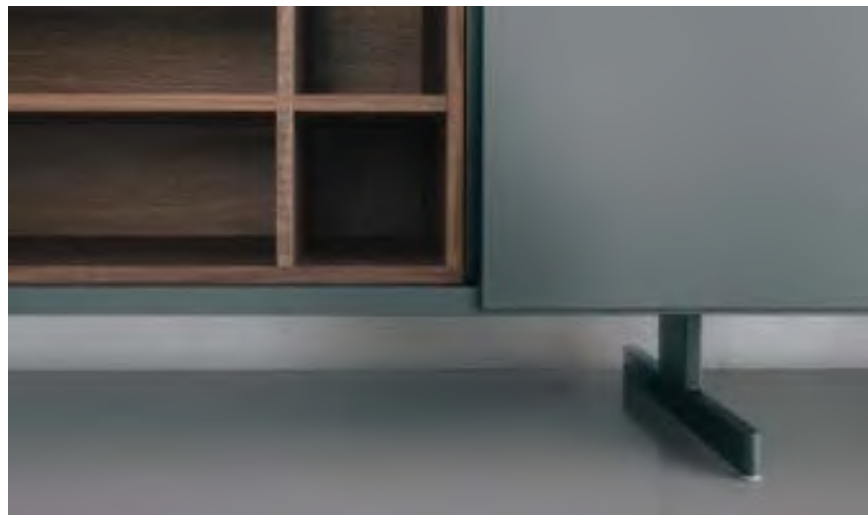

10/MONOLITH

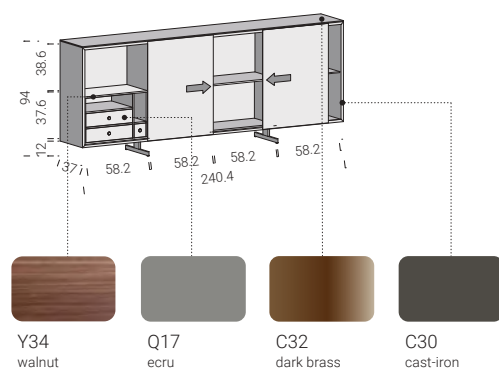

MONOLITH

- Caratteristiche costruttive
- Construction characteristics
- Caractéristiques de construction
- Konstruktionsmerkmale
- Características constructivas



06/MONOLITH

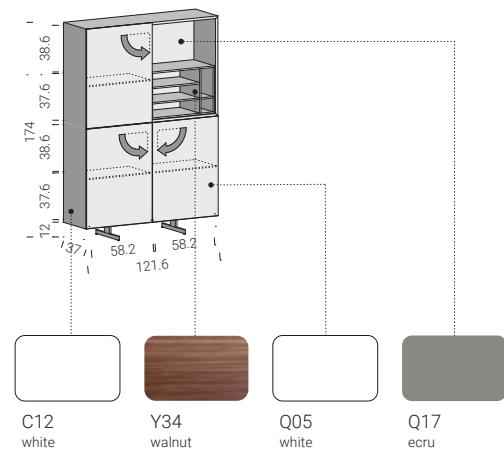

02/MONOLITH

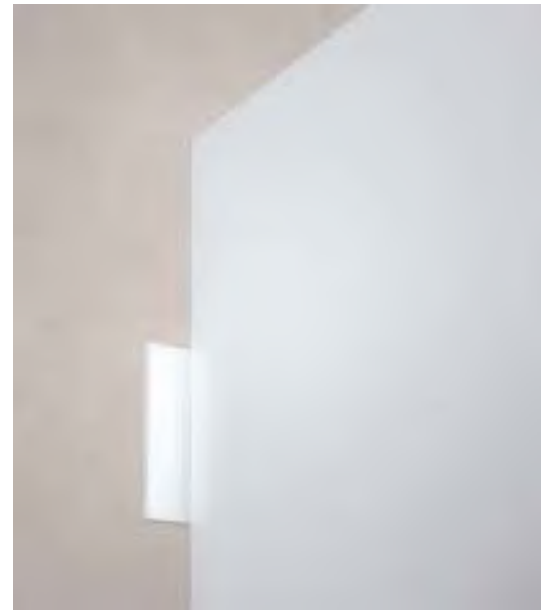
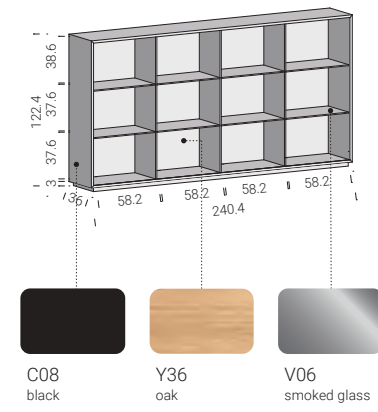

HAMMER pg. 210

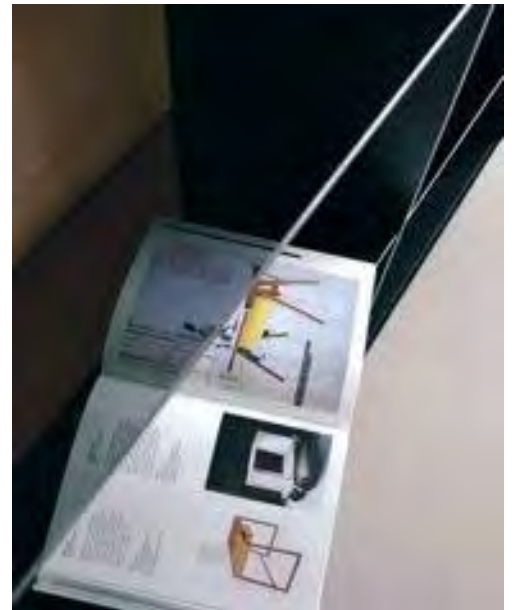
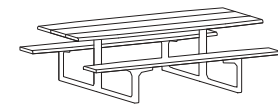

# 02A/MONOLITH

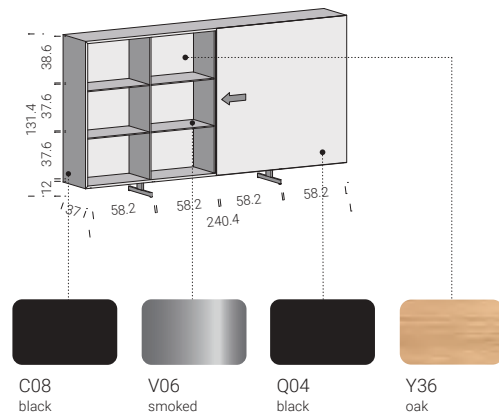

SPILLO pg. 158



05/MONOLITH

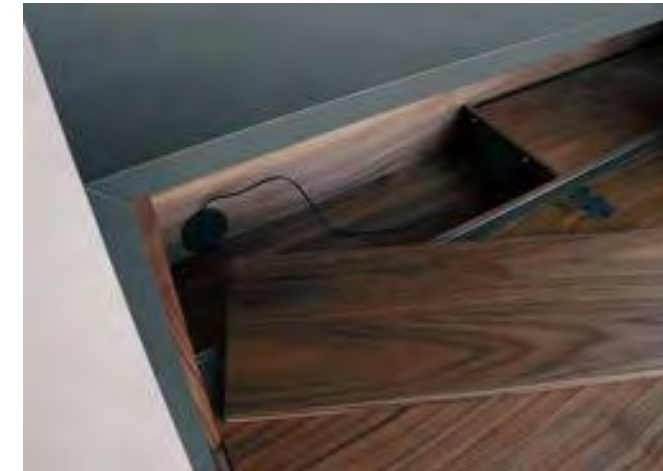
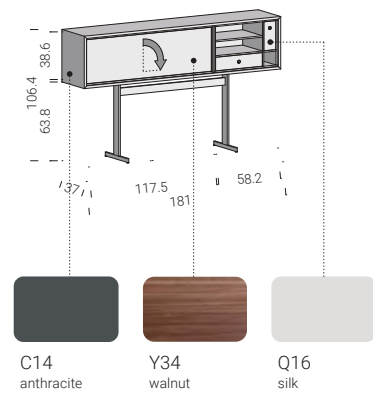

MONOLITH

- Scrivania
- Writing desk
- Bureau
- Schreibtisch
- Escritorio

XY

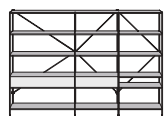

IL BREVETTO XY CONSENTE DI POSIZIONARE I RIPIANI LUNGO L'ASSE VERTICALE Y E LE COPPIE DI PROFILI PORTANTI LUNGO L'ASSE ORIZZONTALE X. IL POSIZIONAMENTO IN X ED Y AVVIENE IN CONTINUO, SENZA POSIZIONI PREDEFINITE. CIÒ COSTITUISCE UN'OSSATURA PORTANTE IN GRADO DI ESSERE ALLESTITA CON SCHIENE, FIANCHI, ANTE A RIBALTA, ANTE A BATTENTE, CASSETTIERE.

The patented XY system enables you to position the shelves along vertical Y-axis and the pairs of load-bearing profiles along horizontal X-axis. Positioning along X and Y is completely free, without any preset positions. This creates a load-bearing framework that can be completed with backs, sides, tilting or leaf doors, drawer units.

Le brevet XY permet de positionner les étagères le long de l'axe vertical Y et les paires de profilés portants le long de l'axe horizontal X. Le positionnement suivant X et Y s'effectue en continu, sans positions prédéfinies. Ceci réalise une structure portante susceptible d'être équipée de fonds, côtés, portes à rabattant, portes à battant, kits de tiroirs.

Das Patent XY ermöglicht es, die Böden längs der vertikalen Y-Achse und die tragenden Profilpaare längs der horizontalen X-Achse zu positionieren. Dabei kann die Positionierung auf X und Y an jeder Stelle ohne voreingestellte Positionen erfolgen. Auf diese Weise wird eine tragende Struktur gebildet, die mit Rück- und Seitenwänden, Klapp- und Flügeltüren, Schubladenelementen.

La patente XY permite colocar los estantes a lo largo del eje vertical Y y las parejas de perfiles portantes a lo largo del eje horizontal X. La colocación en X e Y se produce en continuo, sin posiciones previamente definidas. Esto forma un armazón portante capaz de albergar dorso, laterales, puertas abatibles, puertas de batiente, cajoneras.



PRODUCT CONCEPT

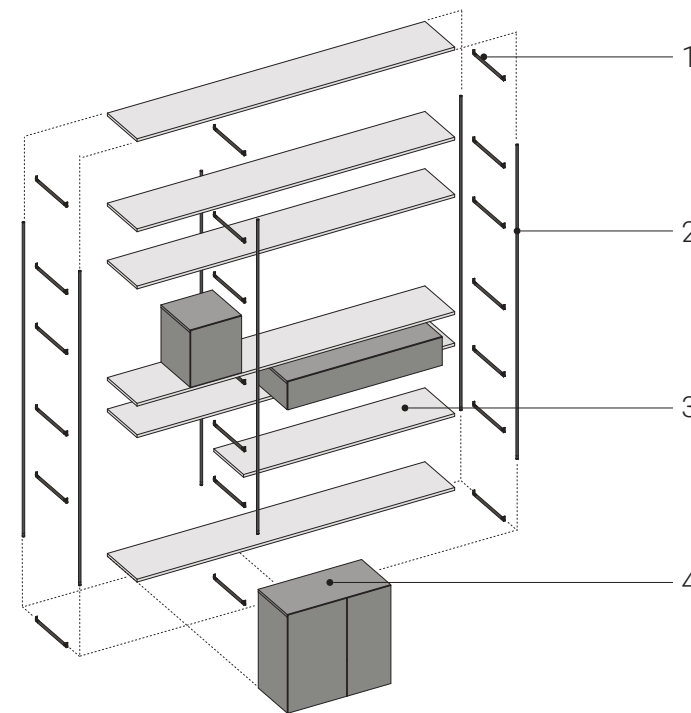

L modules  
36.5 - 73 - 109 - 145

H modules  
reducibile al centimetro  
reducible to the centimetre  
réductible au centimètre  
verkürzbar auf den Zentimeter  
reducible al centimetro

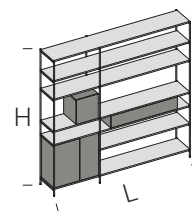

Ripiani hanno libera posizione in altezza, (al cm).  
Contentori hanno libera posizione in altezza e larghezza (al cm).  
Shelves can be positioned at any height, (to the cm).  
Containers can be positioned at any height, (to the cm).  
Les étagères peuvent être positionnées librement en hauteur (au cm près). Les conteneurs peuvent être positionnés librement en hauteur et en largeur (au cm près).  
Einlegeböden sind in der Höhe frei einsetzbar (auf den cm). Behälter sind in der Höhe und in der Breite frei einsetzbar (auf den cm).  
Los estantes tienen posicionamiento libre en altura (al cm). Los contenedores tienen posicionamiento libre en altura y anchura (al cm).

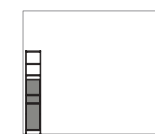

Pavimento / parete  
Floor / wall  
Sol / mur  
Boden / Wand  
Suelo / pared

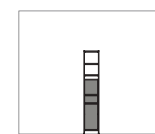

Centro stanza  
Room divider units  
Centre de la pièce  
Zimmermitte  
Centro de la habitación



Riduzioni a misura disponibili su profili verticali, ripiani, fianchi e schiene a giorno.  
Measurement reductions available on vertical profiles, shelves and exposed backs.  
Réductions sur mesure possibles pour les profilés verticaux, les étagères, les panneaux latéraux et les fonds ouverts.  
Verkürzung nach Kundenwunsch auf vertikalen Profilen, Einlegeböden, Seitenteilen und offenen Rückenteilen.  
Las reducciones de tamaño se pueden realizar en los perfiles verticales, los estantes, los laterales y los respaldos abiertos



Passacavi disponibili su contenitori.  
Cable sleeves available on containers.  
Des passe-câbles sont disponibles sur les conteneurs.  
Kabeldurchgänge auf Behälter verfügbar.  
Pasacables disponibles en los contenedores.

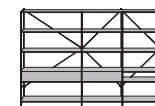

Sistema XY brevettato  
Patented XY system  
Système XY breveté  
Patentiertes XY System  
Sistema XY patentado

1

I nodi, con funzione di supporto ed unione tra coppie di profili verticali e ripiani, sono in alluminio estruso / pressofuso.  
The nodes, that support and join couples of vertical profiles and shelves, are made of extruded / die-cast aluminium.  
Les nœuds, avec fonction de support et d'union entre les paires de profilés verticaux et les étagères, sont en aluminium extrudé/moulé sous pression.  
Die Knotenpunkte dienen als Stütze und Verbindung zwischen vertikalen Profilpaaren und Einlegeböden und sind aus extrudiertem /gegossenem Aluminium.  
Los nodos, que soportan y unen pares de perfiles verticales y estantes, son de aluminio extruido / fundido a presión.

3

I ripiani in estruso di alluminio spessore 20mm sono stati progettati in ogni minimo dettaglio per ottenere le massime performance di resistenza al carico con il minimo impiego di materiale.  
Each and every detail of the extruded aluminium shelves has been designed to achieve maximum load resistance with the minimum amount of material.  
Les étagères en aluminium extrudé de 20 mm d'épaisseur ont été conçues dans les moindres détails pour obtenir des performances de résistance à la charge maximum en utilisant le moins de matériau possible.  
Die Einlegeböden aus extrudiertem Aluminium, Dicke 20 mm, wurden in jedem kleinsten Detail entworfen, um die höchste Belastbarkeit bei der niedrigsten Menge an verwendetem Material zu erhalten.  
Los estantes de aluminio extruido de 20 mm de grosor se han diseñado hasta el más mínimo detalle para lograr el máximo rendimiento de carga con el mínimo uso de material.

2

Le coppie di profili verticali sono in alluminio estruso con sezione circolare diametro 15mm. La finitura viene eseguita con verniciatura a polveri a 180°.  
The pairs of vertical profiles are made of extruded aluminium with circular section, diameter 15 mm. 180° powder coating finish.  
Les paires de profilés verticaux sont en aluminium extrudé à section circulaire de 15 mm de diamètre. Les finitions sont réalisées avec peinture à poudre à 180°.  
Die vertikalen Profilpaare sind aus extrudiertem Aluminium mit kreisförmigem Querschnitt und einem Durchmesser von 15 mm. Die Beschichtung wird durch Pulverlackieren bei 180° ausgeführt.  
Los pares de perfiles verticales son de aluminio extruido con un diámetro de sección circular de 15 mm. Están acabados con un revestimiento de polvo a 180°.

4

I contenitori, disponibili in essenza e laccato, sono configurabili con frontali in HPL o vetro temprato, di soli 4mm di spessore. La semplificazione delle geometrie rende il volume compatto e raffinato.  
The containers, available in wood species and lacquered, can have HPL or tempered glass fronts with a thickness of just 4 mm. The simplicity of the geometries makes the unit compact and elegant.  
Les conteneurs, disponibles en bois et laqués, peuvent être configurés avec des façades en HPL ou en verre trempé de seulement 4 mm d'épaisseur. La simplification des géométries rend le volume compact et épuré.  
Die Behälter sind aus Holznachbildung oder lackiert verfügbar und sind mit der Stirnseite aus HPL oder Hartglas mit einer Stärke von nur 4 mm konfigurierbar. Die Vereinfachung der Formen machen das Volumen kompakt und raffiniert.  
Los contenedores, disponibles en madera y lacados, pueden configurarse con frentes de HPL o de vidrio templado, de sólo 4 mm de grosor. La simplificación de las geometrías hace que el volumen sea compacto y refinado.



## FINITURE/FINISHES

### telaio / structure

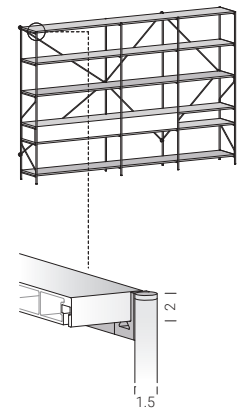

alluminio verniciato  
painted aluminium



## DIMENSIONI/DIMENSIONS

verificare a listino dimensioni e finiture  
check dimensions and finishes in the price list

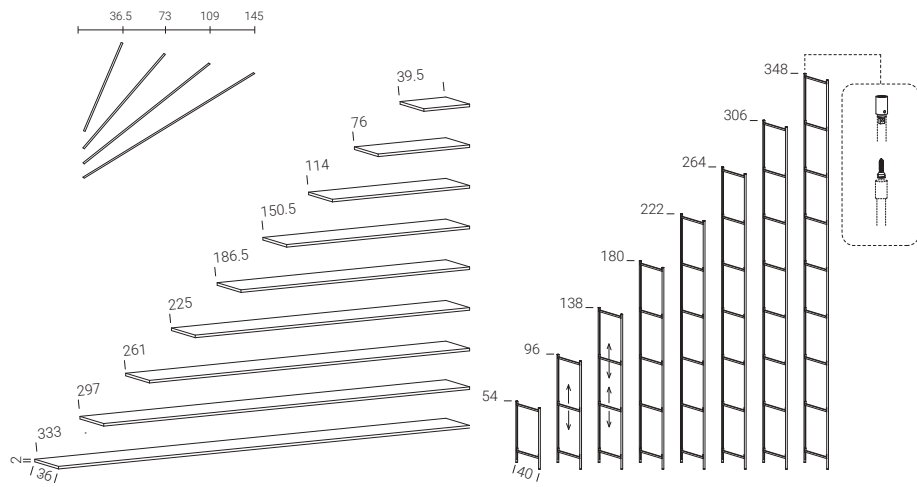

cm disponibili riduzioni a misura / tailor-made reduction available

## FINITURE/FINISHES

### schiene e fianchi / backs and sides

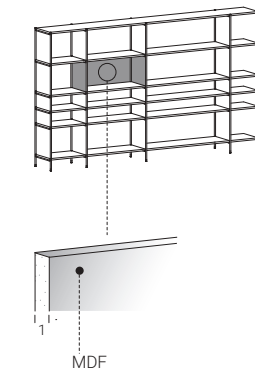

laccato  
lacquered

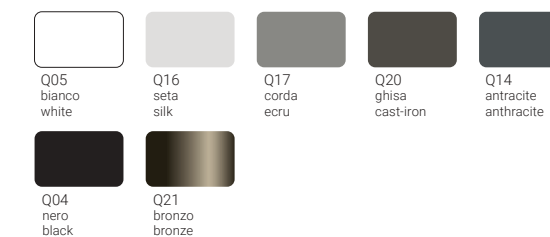

essenza  
wood

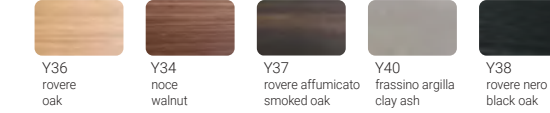

## DIMENSIONI/DIMENSIONS

verificare a listino dimensioni e finiture  
check dimensions and finishes in the price list

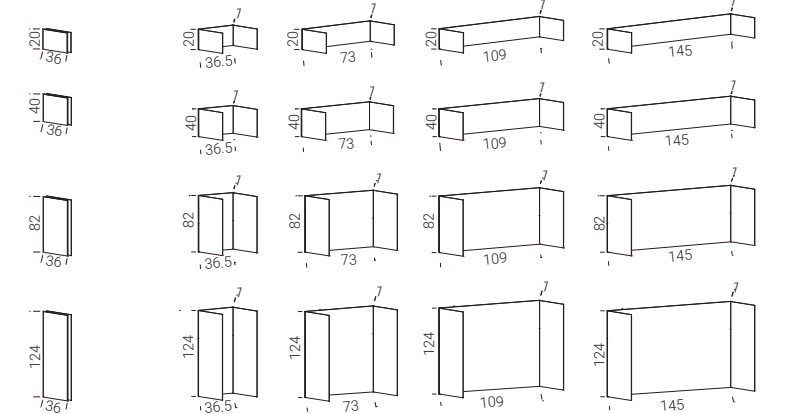

cm disponibili riduzioni a misura / tailor-made reduction available

### contenitori / cabinets

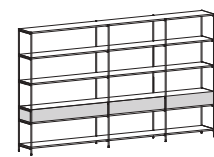

laccato  
lacquered



essenze  
woods



laccato metallo  
metal lacquer

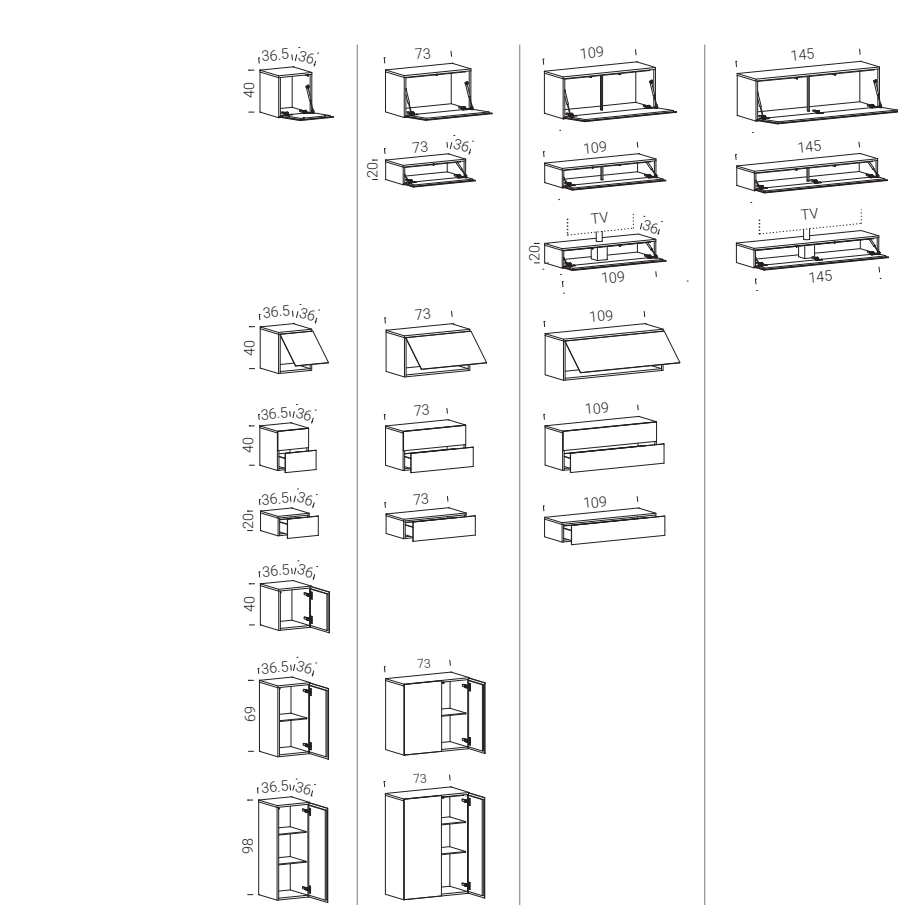

### top

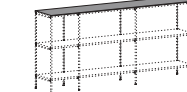

POLARIS® / FENIX®



HPL + legno  
HPL + wood

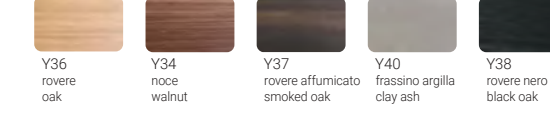

HPL laccato  
lacquered HPL

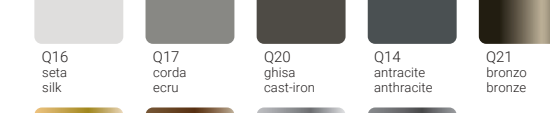

HPL + metallo  
HPL + metal

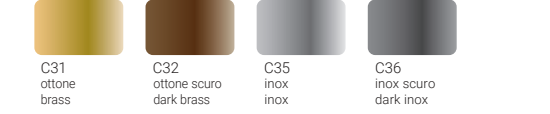

HPL + ecotouch



HPL + cemento  
HPL + cement

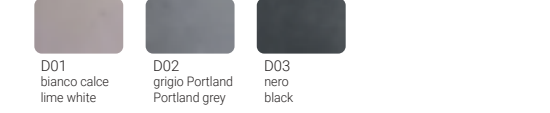

ceramica  
ceramic

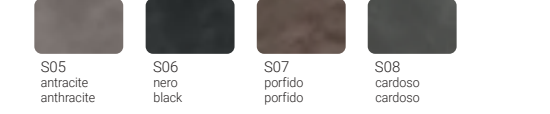

cm disponibili riduzioni a misura / tailor-made reduction available

32/XY

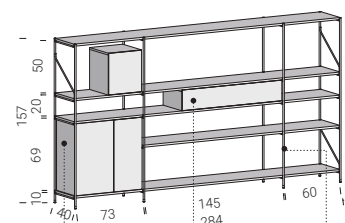

Q21  
bronze



Y37  
smoked oak



C29  
bronze



XY

- Sistema brevettato
- Patented system
- Système breveté
- Patentiertes system
- Sistema patentado



31/XY

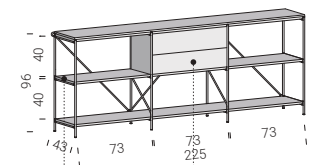

C12  
white



X01  
copper



33/XY

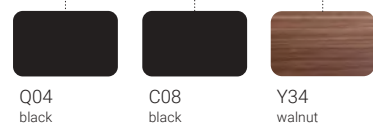
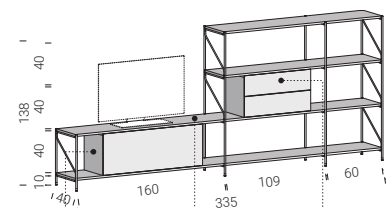

Q04  
black

C08  
black

Y34  
walnut



XY

- Dettaglio anta
- Detail of a door
- Détail de la porte
- Türdetail
- Detalle de la puerta





30/XY

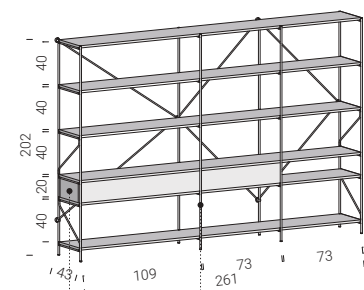

Q04  
black



C08  
black







29/XY

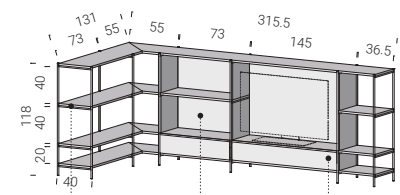

- C08 black
- Y34 walnut
- Q04 black





09/XY

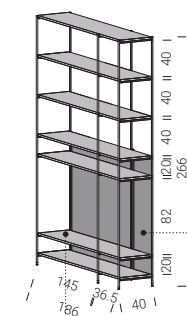

C30  
cast-iron



Q20  
cast-iron



34/XY

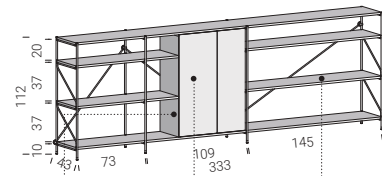

Q20  
cast-iron



Y37  
smoked oak



C30  
cast-iron

ECH9 pg. 334



ST35 pg. 186

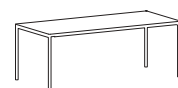

CONTRAPPESO pg. 340

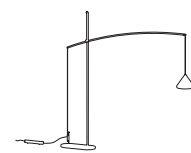

# SYSTEM

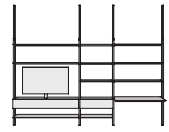

IL SISTEMA BREVETTATO EXTENDO È FORMATO DA DUE PROFILI IN ALLUMINIO ESTENSIBILI, ADATTABILI ALLE DIVERSE ALTEZZE DEGLI AMBIENTI. AGENDO SULLA LEVA A SCOMPARSA, I PROFILI SI BLOCCANO ALL'ALTEZZA DESIDERATA E SI COMPRIMONO TRA PAVIMENTO E SOFFITTO, SENZA L'UTILIZZO DI ALCUN UTENSILE O PRE-FISSAGGIO.

The patented extendo system consists of two extendable aluminium profiles that can be adapted to environments of various heights. Using the foldaway lever, the profiles can be blocked at the desired height and compressed between floor and ceiling, without having to use any kind of pre-fixing tool.

Le système breveté extendo est constitué de deux profilés extensibles en aluminium pouvant être adaptés aux différentes hauteurs des milieux. En agissant sur le levier escamotable, les profilés se verrouillent à la hauteur souhaitée et se compriment entre plancher et plafond, sans utiliser aucun outil ou préfixation.

Das patentierte System extendo besteht aus zwei ausziehbaren Aluminium-Profilen, die an unterschiedliche Raumhöhen angepasst werden können. Durch einen versenkbaren Hebel werden die Profile auf der gewünschten Höhe blockiert und zwischen Fußboden und Zimmerdecke ohne Werkzeug oder Vor-Befestigung komprimiert eingesetzt.

El sistema patentado extendo está formado por dos perfiles de aluminio extensibles, adaptables a las distintas alturas de los ambientes. Actuando sobre la palanca escondida, los perfiles se bloquean a la altura deseada y se comprimen entre el suelo y el techo, sin que sea necesario utilizar ninguna herramienta o fijación previa.

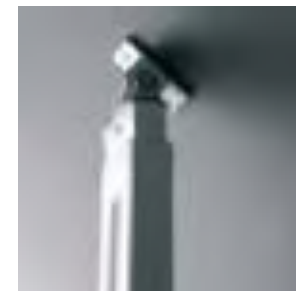
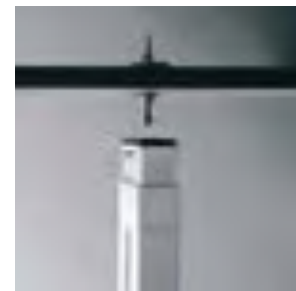

## PRODUCT CONCEPT

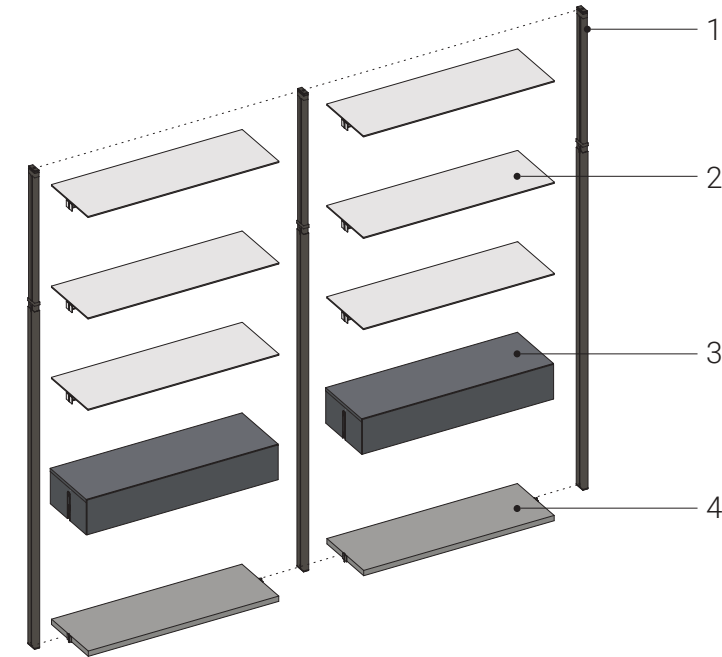

L modules  
36 - 72 - 108 - 144

H modules  
210 / 400

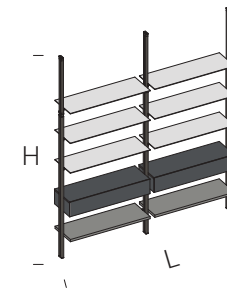

Ripiani e contenitori hanno libera posizione in altezza, (al centimetro).

Shelves and containers can be positioned at any height (to the centimetre).

Les étagères et les conteneurs peuvent être positionnés librement en hauteur (au centimètre près).

Einlegeböden und Behälter sind in der Höhe frei einsetzbar (auf den Zentimeter).

Los estantes y contenedores tienen una altura libre (al centímetro).

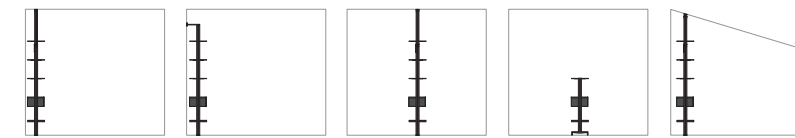

Pavimento / soffitto  
Floor / ceiling  
Sol / plafond  
Boden / Decke  
Suelo/techo

Pavimento / parete  
Floor / wall  
Sol / mur  
Boden / Wand  
Suelo / pared

Bifacciale  
Double-sided  
Double face  
Zweiseitig  
Doble cara

Pavimento / bifacciale  
Floor / Double-sided  
Sol / Double face  
Boden / Zweiseitig  
Suelo / Doble cara

Soffitto inclinato  
Sloping ceiling  
Plafond incliné  
Schräge Decke  
Techo inclinado



Riduzioni a misura disponibili su profili verticali e ripiani.  
Measurement reductions available on vertical profiles and shelves.

Réductions sur mesure possibles pour les profilés verticaux et les étagères.  
Verkürzung nach Kundenwunsch auf vertikalen Profilen und Einlegeböden.  
Reducciones de tamaño disponibles en los perfiles verticales y los estantes.



Passacavi disponibili su contenitori.  
Cable sleeves available on containers.

Des passe-câbles sont disponibles sur les conteneurs.  
Kabeldurchgänge auf Behälter verfügbar.  
Pasacables disponibles en los contenedores.

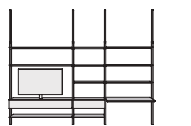

Profilo telescopico brevettato  
Patented telescopic profile  
Profilé télescopique breveté  
Patentiertes teleskopisches Profil  
Perfil telescópico patentado



I profili in alluminio estruso, sono configurabili per adattarsi alle diverse esigenze degli ambienti. Sono infatti possibili configurazioni per installazioni a soffitto, parete, bifacciale e soffitto inclinato.

The extruded aluminium profiles are modular, to adapt to the needs of the spaces. Indeed, configurations are available for ceiling, wall, double-sided and sloping ceiling mounting.

Les profilés en aluminium extrudé peuvent être configurés pour s'adapter aux différents besoins des espaces. En effet, des configurations pour des installations au plafond, au mur, en double face et sur plafond incliné sont possibles.

Die Profile aus extrudiertem Aluminium sind gestaltbar, um sich an die verschiedenen Anforderungen der Räume anzupassen. Es sind nämlich Konfigurationen für die Montage an der Decke, an der Wand, zwei-seitig und an schräger Decke möglich.

Los perfiles de aluminio extruido pueden configurarse para adaptarse a los diferentes requisitos de la sala. De hecho, son posibles configuraciones para instalaciones en el techo, en la pared, en la bifaz y en el techo inclinado.



I contenitori, disponibili in essenza e laccato, sono configurabili con frontali in HPL o vetro temprato, di soli 4mm di spessore. La semplificazione delle geometrie rende il volume compatto e raffinato.

The containers, available in wood and lacquered, can have HPL or tempered glass fronts with a thickness of just 4 mm. The simplicity of the geometries makes the unit compact and elegant.

Les conteneurs, disponibles en bois et laqués, peuvent être configurés avec des façades en HPL ou en verre trempé de seulement 4 mm d'épaisseur. La simplification des géométries rend le volume compact et épuré.

Die Behälter sind aus Holznachbildung oder lackiert verfügbar und sind mit der Stirnseite aus HPL oder Hartglas mit einer Stärke von nur 4 mm konfigurierbar. Die Vereinfachung der Formen machen das Volumen kompakt und raffiniert.

Los contenedores, disponibles en madera y lacados, pueden configurarse con frentes de HPL o de vidrio templado, de sólo 4 mm de grosor. La simplificación de las geometrías hace que el volumen sea compacto y refinado.



I ripiani a modulo dallo spessore ridottissimo 6/10 mm sono costruiti in HPL o vetro temprato. In entrambe le soluzioni sono accoppiati a profili in acciaio per aumentarne la resistenza ai carichi e all'indeformabilità.

The module shelves, with an extremely small thickness 6/10 mm, are made of HPL or tempered glass. In both solutions they are coupled to steel profiles to increase their resistance to loads and improve dimensional stability.

Les étagères modulables de très faible épaisseur (6/10 mm) sont en HPL ou en verre trempé. Dans les deux solutions, elles sont couplées à des profilés en acier pour augmenter leur résistance aux charges et leur propriété d'indéformabilité.

Die Modul-Einlegeböden mit einer reduzierten Dicke von 6/10 mm sind aus HPL oder aus Hartglas. In beiden Lösungen sind sie mit Stahlprofilen verbunden, um die Belastbarkeit und die Umformfestigkeit zu erhöhen.

Los estantes modulares de 6/10 mm de grosor son de HPL o de vidrio templado, y en ambas soluciones se acoplan con perfiles de acero para aumentar su resistencia a las cargas y su indeformabilidad.



I ripiani in multistrato bilaminato spessore 3cm, rappresentano un'ottima soluzione per ottenere un ripiano leggero e resistente ai carichi, riducibile in lunghezza e profondità.

The 3 cm thick bi-laminated multi-layer shelves are an ideal solution for a light, load resistant shelf with a reduced length and depth.

Les étagères en contreplaqué bi-laminé de 3 cm d'épaisseur sont une excellente solution pour obtenir une étagère légère et résistante à la charge, avec possibilité de réduction en longueur et en profondeur.

Die beidseitig belegten Einlegeböden aus 3 cm dickem Mehrschichtholz sind eine optimale Lösung für einen leichten und belastbaren Einlegeboden, verkürzbar in Länge und Tiefe.

Los estantes de madera contrachapada de 3 cm de grosor son una excelente solución para obtener una estantería ligera y resistente a la carga que puede reducirse en longitud y profundidad.

## FINITURE/FINISHES

### profilo extendo / extendo profile

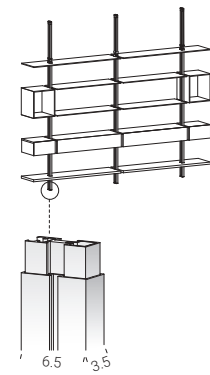

alluminio verniciato  
painted aluminium



### ripiani in multistrato / multilayer shelves

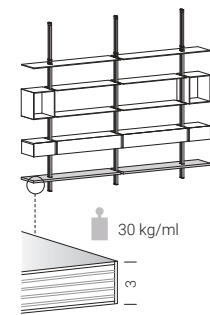

multistrato laccato  
lacquered multilayer

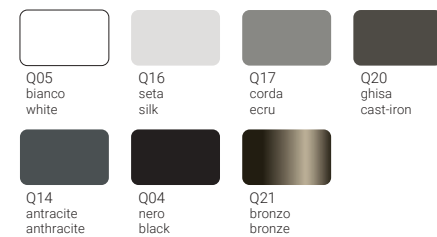

### ripiani in vetro / glass shelves

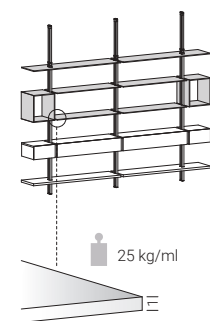

vetro laccato  
tempered glass



vetro trasparente  
transparent glass



## DIMENSIONI/DIMENSIONS

verificare a listino dimensioni e finiture  
check dimensions and finishes in the price list

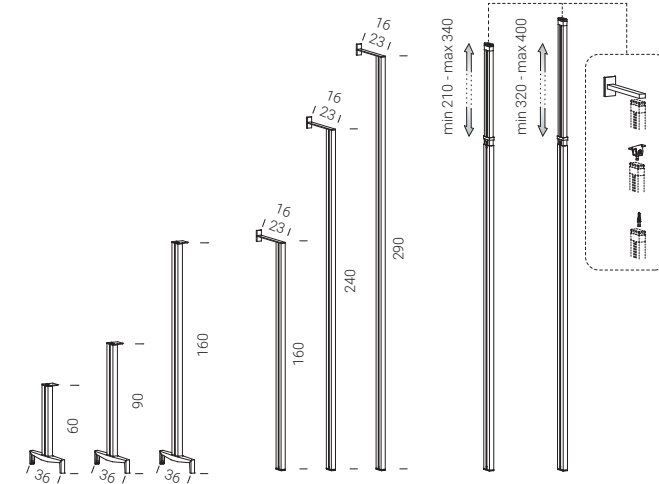

cm disponibili riduzioni a misura / tailor-made reduction available

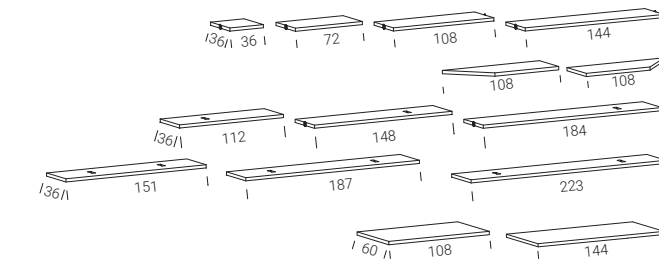

cm disponibili riduzioni a misura / tailor-made reduction available

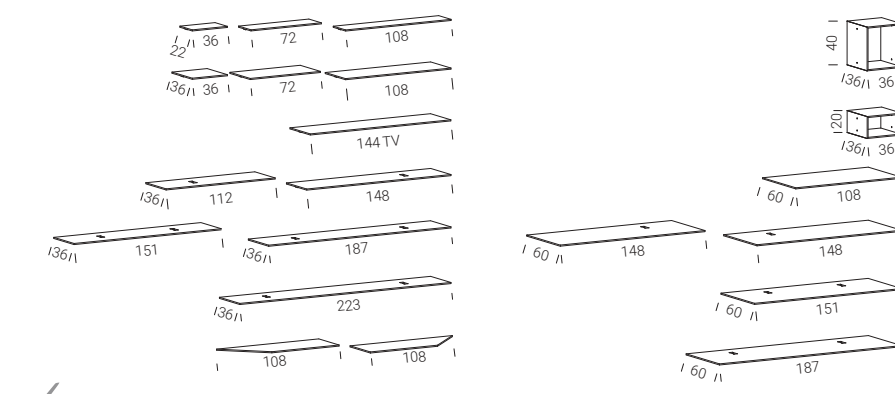

cm disponibili riduzioni a misura / tailor-made reduction available

## FINITURE/FINISHES

### ripiani in HPL / HPL shelves

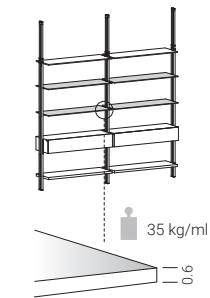

POLARIS®

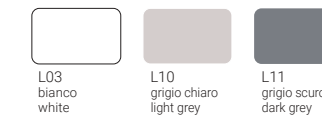

FENIX®



HPL + legno  
HPL + wood

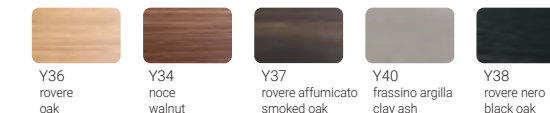

HPL laccato  
lacquered HPL



### contenitori / cabinets

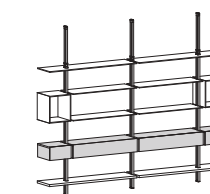

laccato  
lacquered



essenze  
woods

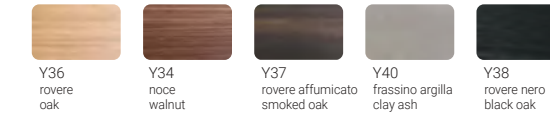

laccato metallo  
metal lacquer



## DIMENSIONI/DIMENSIONS

verificare a listino dimensioni e finiture  
check dimensions and finishes in the price list

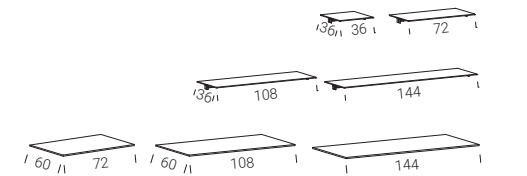

cm disponibili riduzioni a misura / tailor-made reduction available

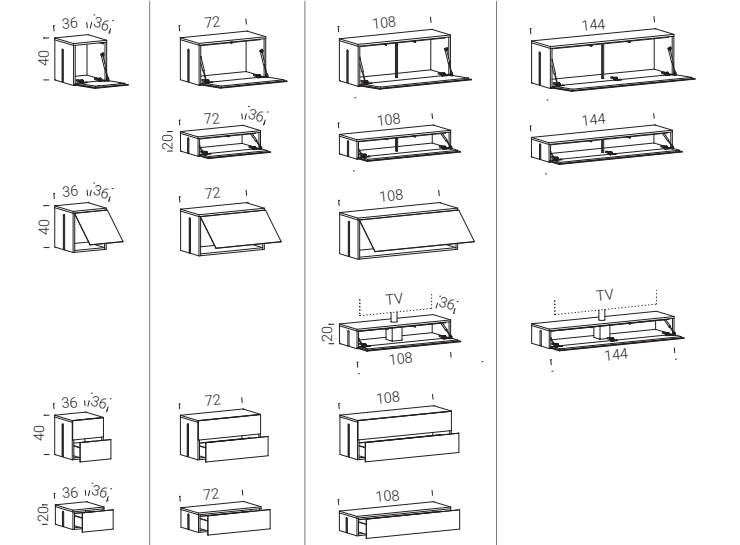

56/SYSTEM

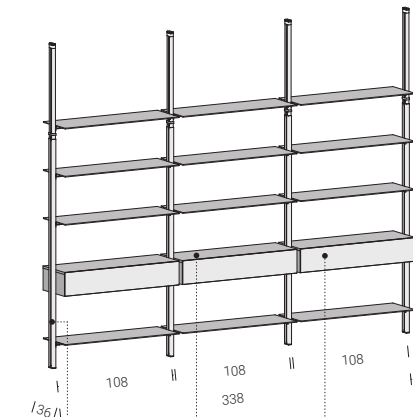

- C30 cast-iron
- Q20 cast-iron
- Y40 clay ash

ECH4 pg. 308



T11 pg. 250



CONTRAPPESO pg. 340

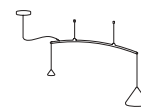

SYSTEM

- Sistema brevettato
- Patented system
- Système breveté
- Patentiertes system
- Sistema patentado



54/SYSTEM

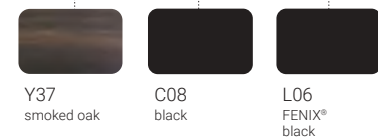
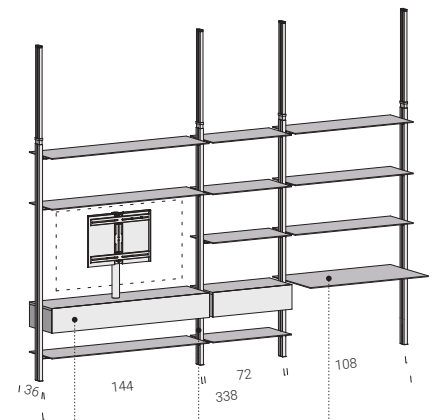

VIKING pg. 294



DÉCO pg. 272



T8 pg. 224







16/SYSTEM

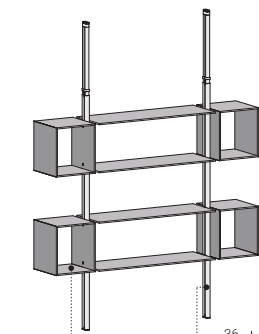

36 108 36  
187



Q04 black C08 black



14/SYSTEM

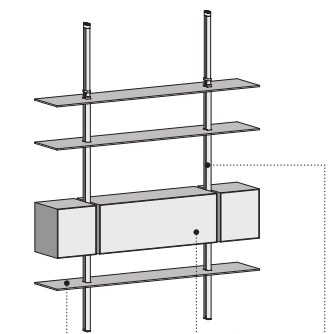

36 108 36  
187



Q04 black Y38 black oak C08 black



03/SYSTEM

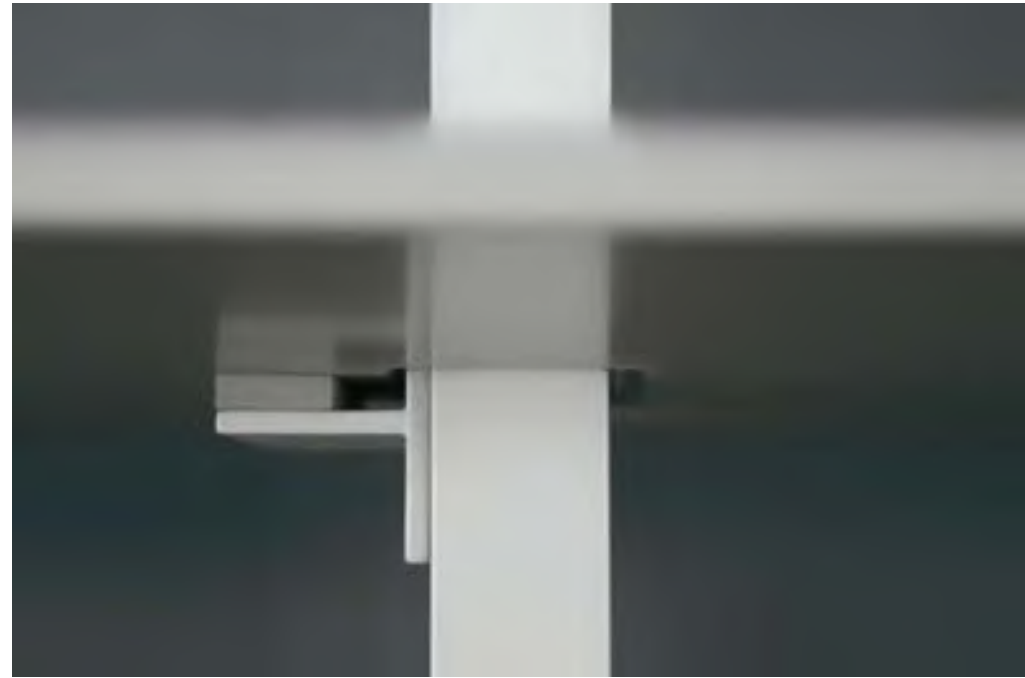
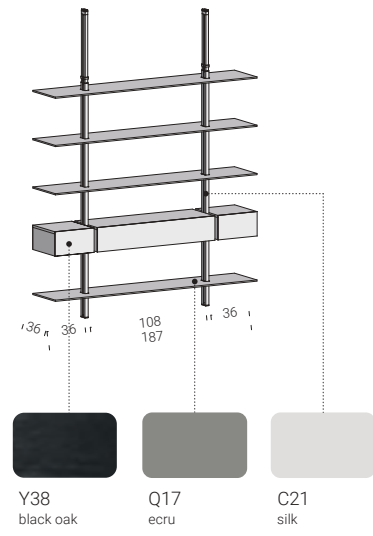

52/SYSTEM

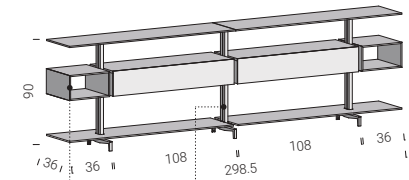

Q04  
black



C08  
black



SYSTEM

- Dettaglio anta
- Detail of a door
- Détail de la porte
- Türdetail
- Detalle de la puerta



53/SYSTEM

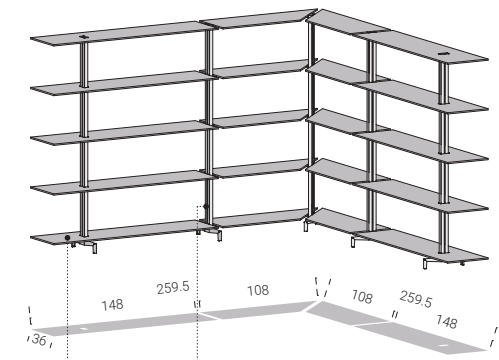

SPILLO pg.158



# TABLES & COFFEE TABLES

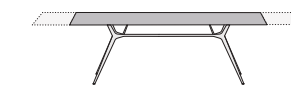

**BALANCE**  
fixed | extendable  
pg. 142

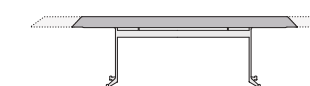

**T9**  
fixed | extendable  
pg. 234



**SPILLO**  
fixed  
pg. 158

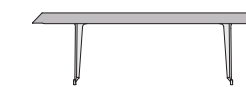

**T10**  
fixed  
pg. 244



**SINTESI**  
fixed | extendable  
pg. 174

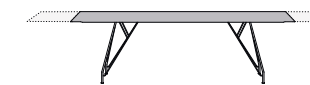

**T11**  
fixed | extendable  
pg. 250

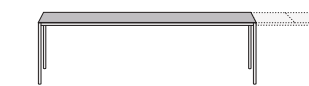

**ST35**  
fixed | extendable  
pg. 186



**T12**  
fixed  
pg. 258

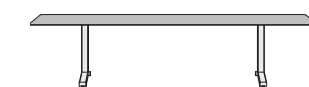

**IPE**  
fixed  
pg. 202



**MR.HYDE**  
fixed | extendable  
pg. 264

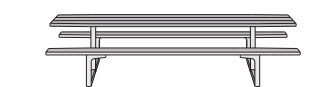

**HAMMER**  
fixed  
pg. 210

## COFFEE TABLES



**SPILLO**  
fixed  
pg. 172

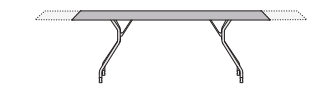

**T7**  
fixed | extendable  
pg. 218



**DÉCO**  
fixed  
pg. 272

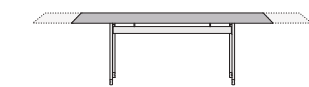

**T8**  
fixed | extendable  
pg. 224



**MR.HYDE**  
fixed | extendable  
pg. 270

# MATERIALI E FINITURE TOP TAVOLI

## TABLE TOPS MATERIALS AND FINISHES

### LEGNO MASSICCIO/SOLID WOOD

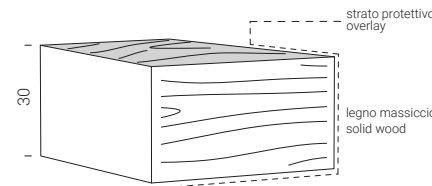
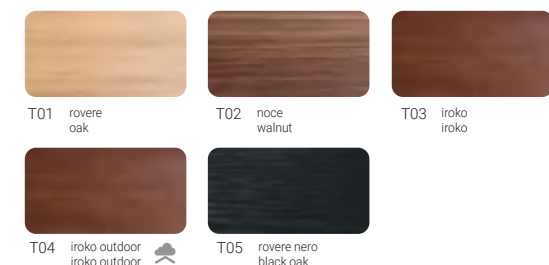

La superficie in legno viene trattata con uno strato di vernice all'acqua (olio per outdoor). Le tavole in legno massiccio sono sottoposte ad un processo di essiccazione per garantirne la stabilità nel tempo. La tecnica di giuntatura a pettine 'finger-joint' contribuisce alla costruzione di un pannello che mantiene la planarità.

The wooden surface is treated with a layer of water-based paint (oil for outdoors). The solid wood boards are subjected to a drying process to ensure their stability over time. The 'finger-joint' technique contributes to the construction of a panel that maintains flatness.

**TABLE TOPS**

- ▶ Caratteristiche tecniche
- ▶ Technical characteristics
- ▶ Caractéristiques techniques
- ▶ Technische merkmale
- ▶ Características técnicas

caratteristiche tecniche technical features

- impatto impact ●●●●○
- calore heat ●○○○○
- graffio scratch ●●●○○
- macchie stains ●●●○○
- acqua water ●●●○○
- esterno riparato sheltered outdoor T01/T02 T03/T05 T04

### POLARIS®

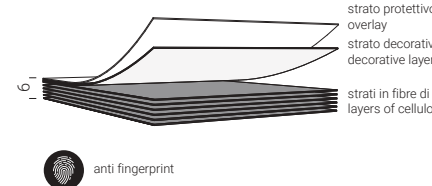

La superficie in finitura POLARIS grazie al trattamento con nanotecnologie è resistente al graffio, morbida al tatto e anti-impronta. Il pannello in HPL full-color di spessore 6mm è costituito da strati di fibre di cellulosa impregnati con resine termoindurenti sottoposti ad un processo di alta pressione (90 kg/cm<sup>2</sup>) ed alta temperatura (150°C).

The Polaris finish surface, thanks to the nanotechnology treatment, is scratch-proof, soft-to-the-touch and anti-fingerprint. The 6 mm thick full-color HPL panel is made of cellulose fibre layers impregnated with thermosetting resins subject to a high pressure (90 kg/cm<sup>2</sup>) and high temperature (150°C) process.

caratteristiche tecniche technical features

- impatto impact ●●●●●
- calore heat ●●●○○
- graffio scratch ●●●○○
- macchie stains ●●●●●
- acqua water ●●●●●
- esterno riparato sheltered outdoor

### FENIX®

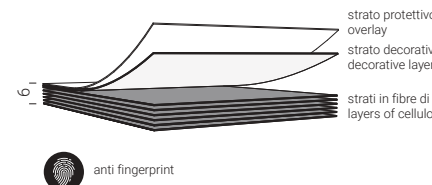

La superficie in finitura Fenix grazie al trattamento con nanotecnologie è resistente al graffio, morbida al tatto e anti-impronta. Il pannello in HPL full-color di spessore 6mm è costituito da strati di fibre di cellulosa impregnati con resine termoindurenti sottoposti ad un processo di alta pressione (90 kg/cm<sup>2</sup>) ed alta temperatura (150°C).

The Fenix finish surface, thanks to the nanotechnology treatment, is scratch-proof, soft-to-the-touch and anti-fingerprint. The 6 mm thick full-color HPL panel is made of cellulose fibre layers impregnated with thermosetting resins subject to a high pressure (90 kg/cm<sup>2</sup>) and high temperature (150°C) process.

caratteristiche tecniche technical features

- impatto impact ●●●●●
- calore heat ●●●○○
- graffio scratch ●●●○○
- macchie stains ●●●●●
- acqua water ●●●●●
- esterno riparato sheltered outdoor

### HPL + LEGNO/HPL + WOOD

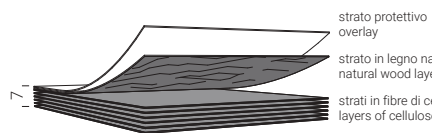

La superficie in legno naturale di spessore 0.6 mm è protetto da una verniciatura all'acqua antigraffio. Il supporto in HPL è costituito da strati di fibre di cellulosa impregnati con resine termoindurenti sottoposti ad un processo di alta pressione (90 kg/cm<sup>2</sup>) ed alta temperatura (150°C).

The 0.6 mm thick natural wood surface is protected by scratch-resistant water-based paint. The support in HPL made of cellulose fibre layers impregnated with thermosetting resins subject to a high pressure (90 kg/cm<sup>2</sup>) and high temperature (150°C) process.

caratteristiche tecniche technical features

- impatto impact ●●●●○
- calore heat ●○○○○
- graffio scratch ●●●○○
- macchie stains ●●●○○
- acqua water ●●●○○
- esterno riparato sheltered outdoor

# MATERIALI E FINITURE TOP TAVOLI

## TABLE TOPS MATERIALS AND FINISHES

### HPL + METALLO/HPL + METAL

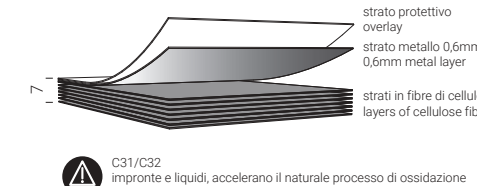
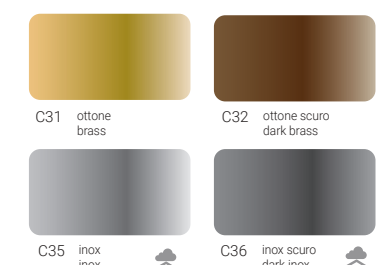

La superficie in ottone/acciaio inox di spessore 0.6 mm ha una lavorazione manuale di spazzolatura vintage; l'ottone è protetto da un film in cera d'api. Il supporto in HPL è costituito da strati di fibre di cellulosa impregnati con resine termoindurenti sottoposti ad un processo di alta pressione (90 kg/cm<sup>2</sup>) ed alta temperatura (150°C).

The 0.6 mm thick brass/stainless steel surface has a vintage manually brushed finish; the brass is protected by a film of beeswax. The support in HPL made of cellulose fibre layers impregnated with thermosetting resins subject to a high pressure (90 kg/cm<sup>2</sup>) and high temperature (150°C) process.

**TABLE TOPS**

- ▶ Caratteristiche tecniche
- ▶ Technical characteristics
- ▶ Caractéristiques techniques
- ▶ Technische merkmale
- ▶ Características técnicas

caratteristiche tecniche technical features

- impatto impact ●●●●○
- calore heat ●●●●●
- graffio scratch ●●●○○
- macchie stains ●●●○○ C31/C32 C35/C36
- acqua water ●●●○○ C31/C32 C35/C36
- esterno riparato sheltered outdoor C31 C32 C35 C36

### HPL + ECOTOUCH

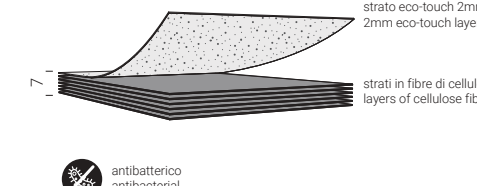
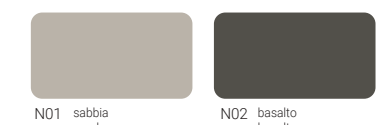

La superficie in eco-touch di spessore 2 mm è un impasto di origine organica 100% naturale (sughero, juta, olio di lino). Il supporto in HPL è costituito da strati di fibre di cellulosa impregnati con resine termoindurenti sottoposti ad un processo di alta pressione (90 kg/cm<sup>2</sup>) ed alta temperatura (150°C).

The 2 mm thick eco-touch surface is a mixture of organic origin and 100% natural (cork, jute, linseed oil). The support in HPL made of cellulose fibre layers impregnated with thermosetting resins subject to a high pressure (90 kg/cm<sup>2</sup>) and high temperature (150°C) process.

caratteristiche tecniche technical features

- impatto impact ●●●○○
- calore heat ●●●○○
- graffio scratch ●○○○○
- macchie stains ●●●●●
- acqua water ●●●○○
- esterno riparato sheltered outdoor

### HPL + CEMENTO/HPL + CONCRETE

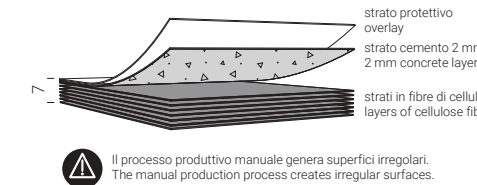
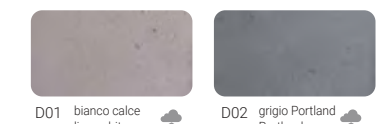

La superficie in cemento di spessore 2mm è un impasto composto da sabbie, inerti e resine, resiste agli impatti e non assorbe i liquidi. Il supporto in HPL è costituito da strati di fibre di cellulosa impregnati con resine termoindurenti sottoposti ad un processo di alta pressione (90 kg/cm<sup>2</sup>) ed alta temperatura (150°C).

The 2 mm thick cement surface is a paste comprising sand, inert materials and resins, withstands impacts and does not absorb liquids. The support in HPL made of cellulose fibre layers impregnated with thermosetting resins subject to a high pressure (90 kg/cm<sup>2</sup>) and high temperature (150°C) process.

caratteristiche tecniche technical features

- impatto impact ●●●○○
- calore heat ●●●●●
- graffio scratch ●●●○○
- macchie stains ●●●●●
- acqua water ●●●●●
- esterno riparato sheltered outdoor

### CERAMICA LAMINAM® / CERAMIC LAMINAM®

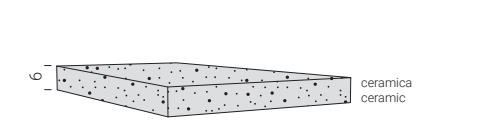
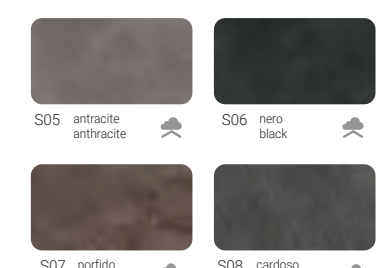

Laminam IN-SIDE è un impasto ceramico di ultima generazione, la cui colorazione di superficie è presente in massa in tutto lo spessore. La superficie ha elevati standard di resistenza al graffio, e per aumentarne la resistenza all'impatto e la sicurezza in caso di rottura, lo strato ceramico è accoppiato ad una rete in fibra di vetro.

Laminam IN-SIDE is a state-of-the-art ceramic paste whose surface colouring permeates its entire thickness. The surface is scratch-proof and the ceramic layer is coupled to a fiberglass panel to increase its resistance to impact and breakage.

caratteristiche tecniche technical features

- impatto impact ●●●○○
- calore heat ●●●●●
- graffio scratch ●●●○○
- macchie stains ●●●●●
- acqua water ●●●●●
- esterno riparato sheltered outdoor

# BALANCE

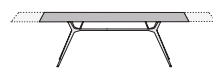

IL SUPPORTO IN ACCIAIO DEI TAVOLI BALANCE COSTITUISCE LA BASE DI UN SISTEMA DI TELAI IN GRADO DI ADATTARSI IN MODO ARMONICO E PROPORZIONATO A TUTTE LE GEOMETRIE DEI TOP DISPONIBILI. LA SEZIONE TRIANGOLARE DERIVA DALLA COMPRESSIONE DI TUBI A SEZIONE CIRCOLARE IN ACCIAIO, TALE COMPRESSIONE AUMENTA LA RESISTENZA DEL SUPPORTO, CONFERENDOGLI UNA SILHOUETTE ELEGANTE E LEGGERA.

The steel support of the Balance tables forms the base of a frame system capable of easily adapting to all the geometries of the tops available. The triangular section comes from compressing circular steel tubes. Such compression increases the strength of the support, giving it an elegant and light silhouette.

Le support en acier des tables balance constitue la base d'un système de structures en mesure de s'adapter de manière harmonieuse et proportionnée à toutes les géométries des plateaux disponibles. La section triangulaire dérive de la compression de tubes à section circulaire en acier, cette compression augmente la résistance du support en lui conférant une silhouette élégante et légère.

Die Stahlbeine der Tische balance bilden die Basis eines Rahmensystems, das sich allen Formen der angebotenen Abschlussborde harmonisch und proportioniert anpasst. Der dreieckige Querschnitt entsteht aus dem Druck der Stahlrohre mit rundem Querschnitt. Dieser Druck erhöht die Festigkeit des Halters und verleiht ihm eine elegante und leichte Silhouette.

El soporte de acero de las mesas Balance constituye la base de un sistema de bastidores que puede adaptarse armoniosamente proporcionado sobre disponibles para todo tipo de geometría. La sección triangular deriva de la compresión de tubos de acero de sección circular. Dicha compresión aumenta la resistencia del soporte, confiriéndole una silueta elegante y ligera.



disponibili riduzioni a misura  
custom reductions available  
réductions sur mesure disponibles  
Verkürzungen auf Maß erhältlich  
disponibles reducciones a medida



passacavo disponibile per tutti i top  
cable gland available for all  
topspasse-câble disponible pour  
tous les plateaux  
Kabeldurchlass für alle  
Abschlussborde verfügbar  
pasacables disponible para todos  
los sobres



Usò in esterno riparato  
Use in a sheltered outdoor  
space  
Utilisation en extérieur, en  
espace abrité  
Verwendung in geschütztem  
Außenbereich  
Usò exterior protegido



EXTENDABLE  
TABLE SYSTEM  
registered community  
design

## FINITURE/FINISHES



uso in esterno riparato  
protected outdoor use

### top tavolo / table top

	legno massiccio solid wood					
	POLARIS®					
	FENIX®					
	HPL + legno HPL + wood					
	HPL + metallo HPL + metal					
	HPL + ecotouch					
	HPL + cemento HPL + cement					
	ceramica ceramic					

### telaio / structure

	acciaio verniciato painted steel					

## DIMENSIONI/DIMENSIONS



verificare a listino geometrie e finiture  
check geometries and finishes in the price list

		120/160/180 x 78 120/160/180 x 90 180 x 98			200 x 78 200/220/240 x 90 200/220/240/300 x 98 200/220/240/300 x 110
		180 x 78 180 x 90 180 x 98			200 x 78 200/220/240 x 90 200/220/240/300 x 98
		180 x 98 180 x 105			200/220/240/300 x 98 200/220/240/300 x 105
		160 x 85 180 x 95			200 x 105 220 x 115 248 x 128
		120/160/180 x 78 120/160/180 x 90 180 x 98			180 x 78 180 x 90 180 x 98
		78 x 78 90 x 90 98 x 98 120 x 120			140 x 140
		78 x 78 90 x 90 98 x 98 120 x 120			140 x 140
		∅ 140 ∅ 160			∅ 110 ∅ 128 ∅ 90
		scrittoi writing desks 100/120/140/160 x 65 160 x 78			180/240/300 x 100
		tavoli allungabili extendable tables 170(260)/200(290)/230(320) x 90 170(260)/200(290)/230(320) x 98			



10/BALANCE

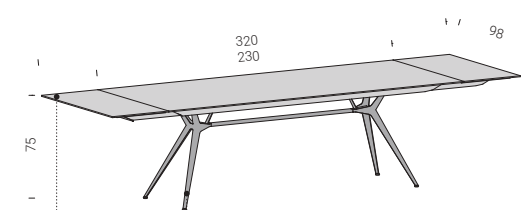

L10  
POLARIS®  
light grey

C08  
black

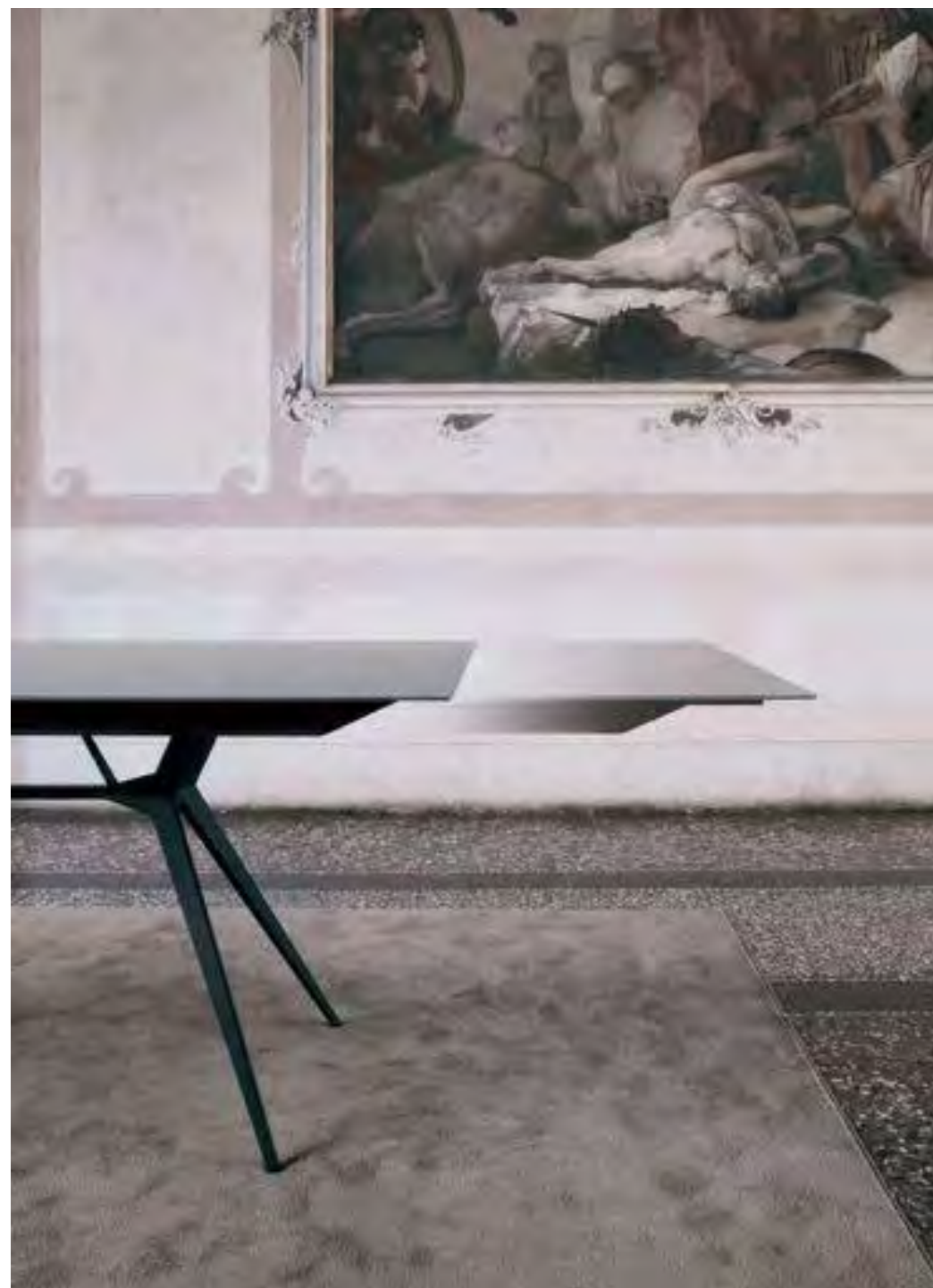

BALANCE

- Apertura allunghe
- Opening of extensions
- Ouverture de rallonges
- Öffnung verlängerungsstücke
- Apertura de la extensión



08/BALANCE

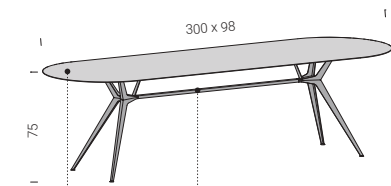

N02  
ecotouch  
basalt



C30  
cast-iron



VIKING pg. 294



ATELIER pg. 46

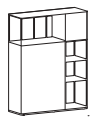

09/BALANCE

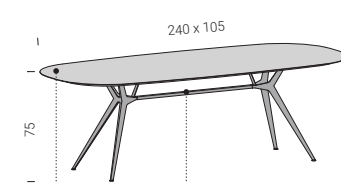

S08  
ceramic  
cardoso

C08  
black

ECH6 pg. 318



CONTRAPPESO pg. 340

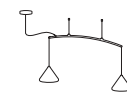

SYSTEM pg. 120

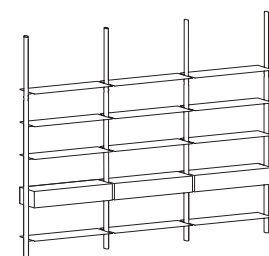

04/BALANCE

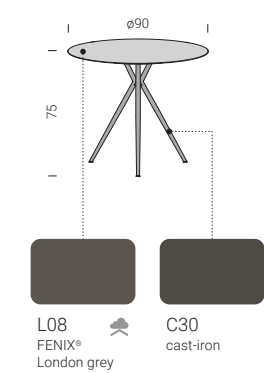

06/BALANCE

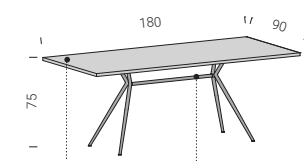

T04  
solid wood  
iroko outdoor



C26  
corten



05/BALANCE

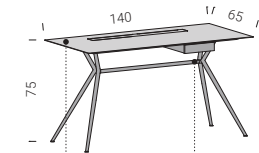

Y34  
walnut

C08  
black

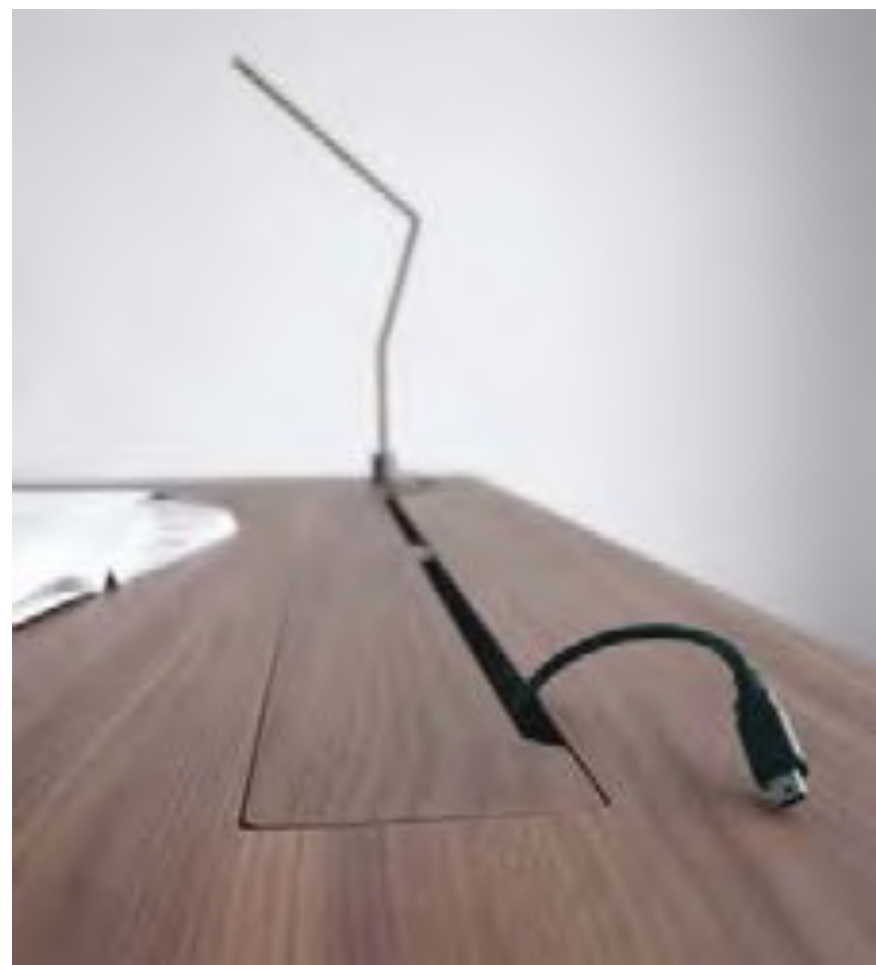

07/BALANCE

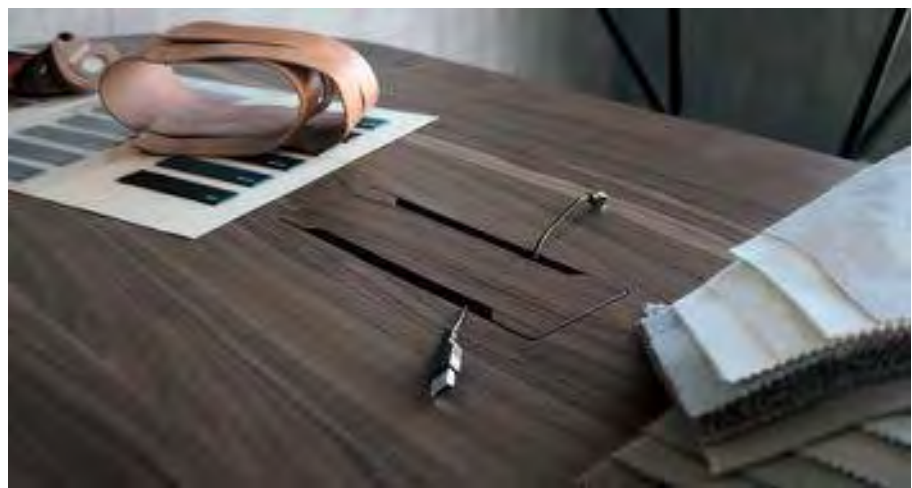
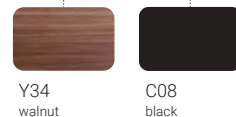
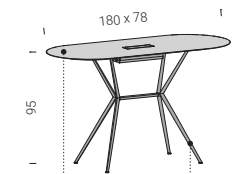

DANSKE C pg. 282



APOLLO pg. 364

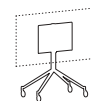

# SPILLO

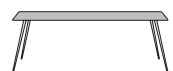

SPILLO È UN TAVOLO DAI MINIMI INGOMBRI VOLUMETRICI, IL TOP IN HPL HA UN BORDO PERIMETRALE VISIBILE DI SOLI 3MM. IL TELAIO IN ACCIAIO SOTTOSTANTE HA GEOMETRIE CHE MASSIMIZZANO LA RESISTENZA E LA RIGIDITÀ DEL TOP, CONSENTENDO LUNGHEZZE SINO A 250 CM. IL TELAIO ED I SUPPORTI A FORMA CONICA IN ACCIAIO COSTITUISCONO UN INSIEME DELLA MASSIMA LEGGEREZZA VOLUMETRICA.

The Spillo table offers minimum volume. The HPL top has a visible perimeter edge of just 3 mm. The underneath steel frame has geometries to maximise the strength and sturdiness of the top, allowing lengths up to 250 cm. The frame and the supports, which are made of steel and conical in shape, give an overall maximum volumetric lightness.

Spillo est une table présentant un encombrement volumétrique minimum, le plateau en HPL a un bord périphérique visible de 3mm seulement. La structure inférieure en acier présente des géométries qui augmentent au maximum la résistance et la rigidité du plateau, permettant des longueurs allant jusqu'à 250 cm. La structure et les supports de forme conique en acier constituent un ensemble de la plus grande légèreté volumétrique.

Spillo ist ein Tisch mit einem minimalem Platzbedarf, das Abschlussbord aus HPL hat eine sichtbare Konturführung von nur 3 mm. Die Geometrien des darunter liegenden Rahmens aus Stahl maximieren die Widerstandsfähigkeit und Steifheit des Abschlussbords und ermöglichen somit Längen von bis zu 250 cm. Die Rahmen und konischen Stützen aus Stahl bilden eine Einheit mit maximaler, volumetrischer Leichtigkeit.

Spillo es una mesa de dimensiones volumétricas mínimas. El sobre de HPL tiene un borde perimetral visible de solo 3 mm. El bastidor inferior de acero posee unas geometrías que maximizan la resistencia y la rigidez del sobre, permitiendo longitudes de hasta 250 cm. El bastidor y los soportes cónicos de acero componen un conjunto de máxima ligereza volumétrica.



Disponibili riduzioni a misura  
Custom reductions available  
Réductions sur mesure disponibles  
Verkürzungen auf Maß erhältlich  
Disponibles reducciones a medida



Passacavo disponibile per tutti i top  
Cable gland available for all  
Topspasse-câble disponible pour tous les plateaux  
Kabeldurchlass für alle Abschlussborde verfügbar  
Pasacables disponible para todos los sobros



Usato in esterno riparato  
Use in a sheltered outdoor space  
Utilisation en extérieur, en espace abrité  
Verwendung in geschütztem Außenbereich  
Uso exterior protegido

## FINITURE/FINISHES



uso in esterno riparato  
protected outdoor use

### top tavolo / table top

0.6	0.3	POLARIS®	L03 bianco white	L10 grigio chiaro light grey	L11 grigio scuro dark grey			
0.6	0.3	FENIX®	L08 grigio Londra London grey	L06 nero black				
0.7	0.3	HPL + legno HPL + wood	Y36 rovere oak	Y34 noce walnut	Y37 rovere affumicato smoked oak	Y40 frassino argilla clay ash	Y39 frassino nero black ash	
0.7	0.3	HPL + metallo HPL + metal	C31 ottone brass	C32 ottone scuro dark brass	C35 inox inox	C36 inox scuro dark inox		
0.7	0.3	HPL + ecotouch	N01 sabbia sand	N02 basalto basalt				
0.7	0.3	HPL + cemento HPL + cement	D01 bianco calce lime white	D02 grigio Portland Portland grey	D03 nero black			
0.8		ceramica ceramic	S05 antracite anthracite	S06 nero black	S07 porfido porfido	S08 cardoso cardoso		

### telaio / structure

1.3		acciaio verniciato painted steel	C12 bianco white	C21 seta silk	C23 corda ecru	C30 ghisa cast-iron	C14 antracite anthracite	
			C08 nero black	C18 verde green	C26 corten corten	C29 bronzo bronze	C37 rame copper	
			C38 titanio titanium					

## DIMENSIONI/DIMENSIONS



verificare a listino geometrie e finiture  
check geometries and finishes in the price list

	130/150/180/200 x 78 180/200/220/250 x 90 150/180/200/220/250 x 98		78 x 78 90 x 90 98 x 98 120 x 120 140 x 140
	180/200 x 78 180/200/220/250 x 90 180/200/220/250 x 98		
	180/200/220/250 x 98 180/200/220/250 x 105		
	160 x 85 180 x 95 200 x 105 220 x 115 248 x 128		
	ø 128 ø 140 ø 160		ø 90 ø 110
	ø 128 ø 140 ø 160		120 x 120 140 x 140
	ø 70 ø 80 ø 90		ø 45 ø 55
	90 x 50 110 x 50		90 x 55 110 x 65



28/SPILLO

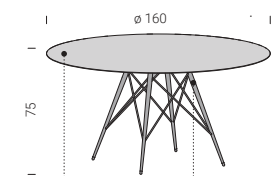

S06  
ceramic  
black

C08  
black



ECH5 pg. 314



CONTRAPPESO pg. 340

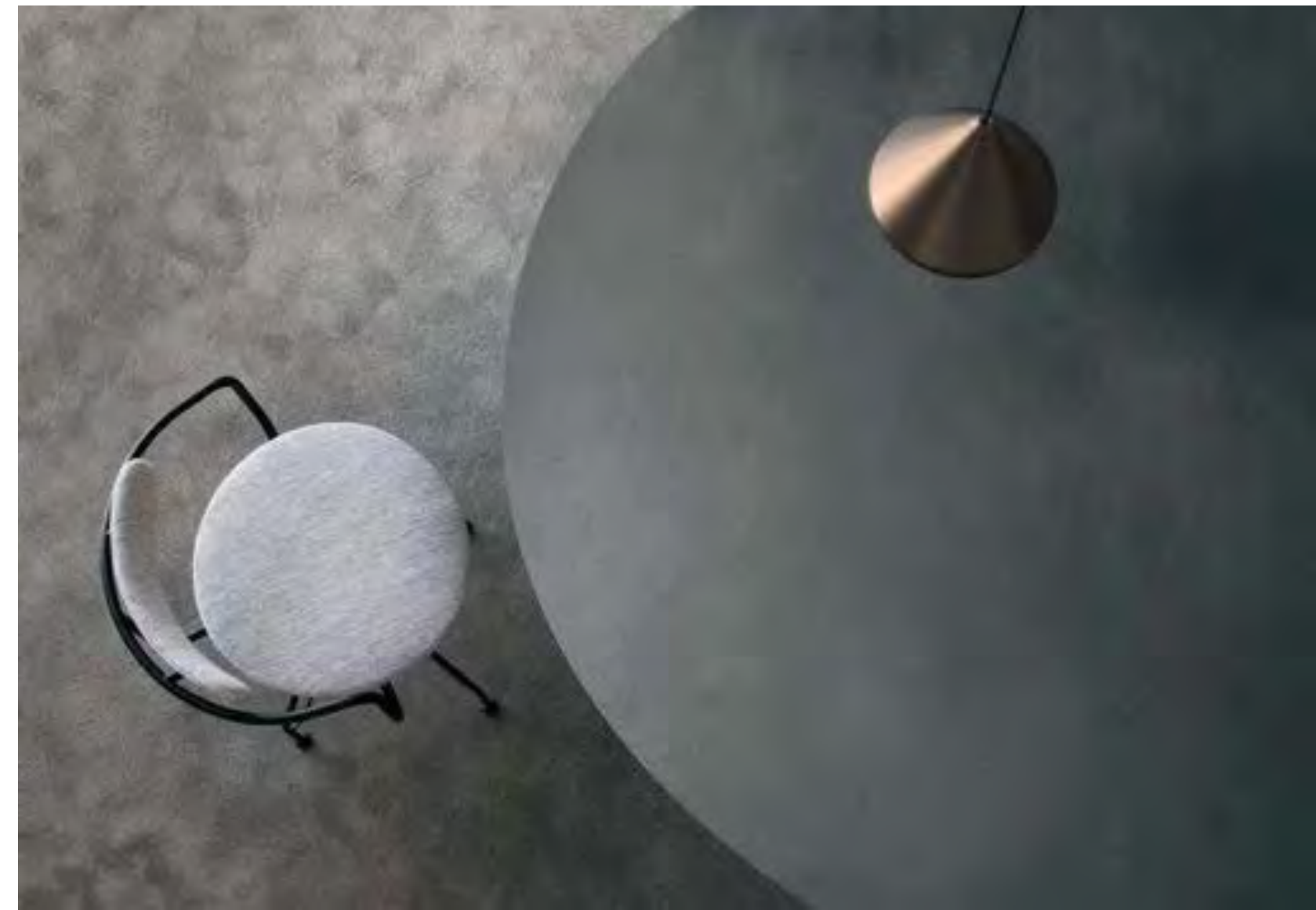
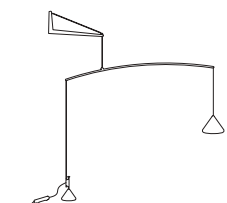

24/SPILLO

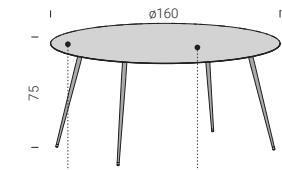

L06  
FENIX®  
black

C08  
black



04/SPILLO

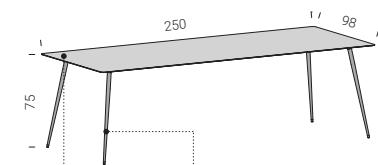

L06  
FENIX®  
black

C08  
black

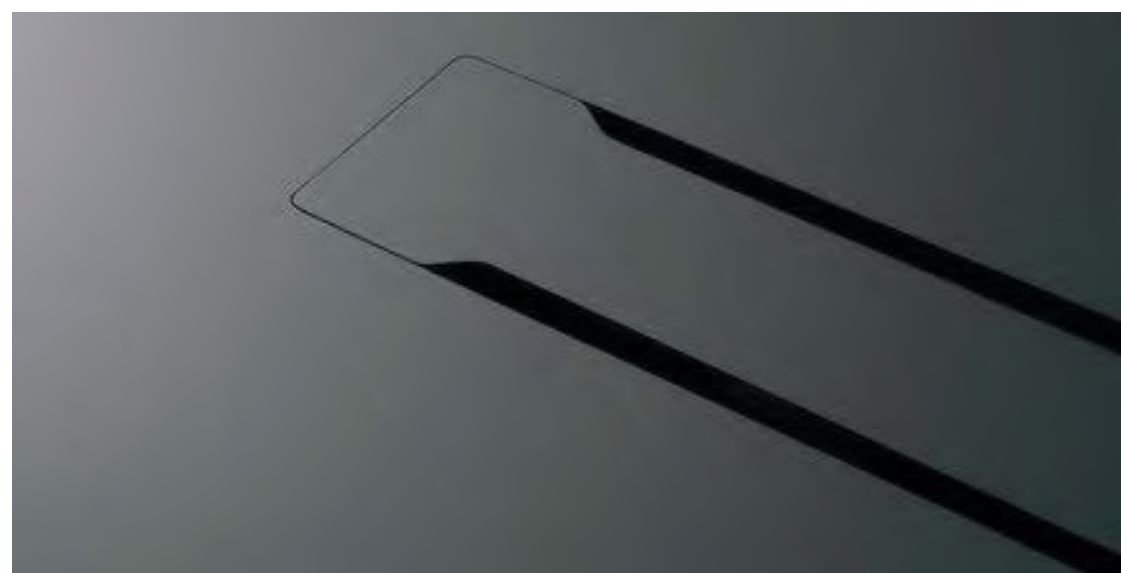

05/SPILLO

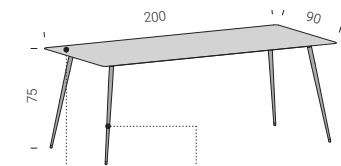

Y36  
oak



C30  
cast-iron



21/SPILLO

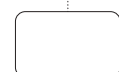
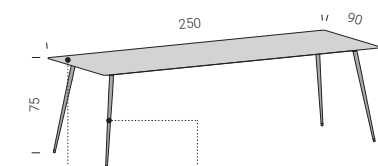

L03  
POLARIS®  
white

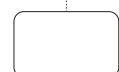

C12  
white



MONOLITH pg. 74

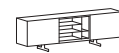

25/SPILLO

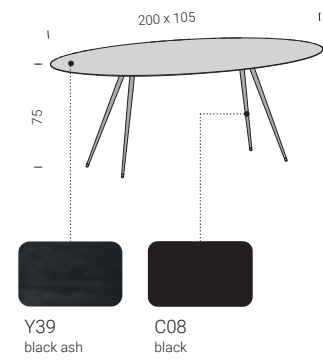

DANSKE C pg. 282



MONOLITH pg. 74

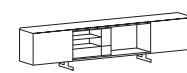

22/SPILLO

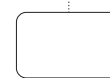
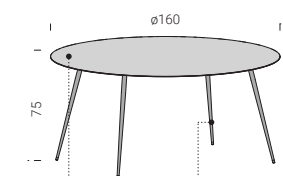

L03  
POLARIS®  
white



C12  
white



26/SPILLO

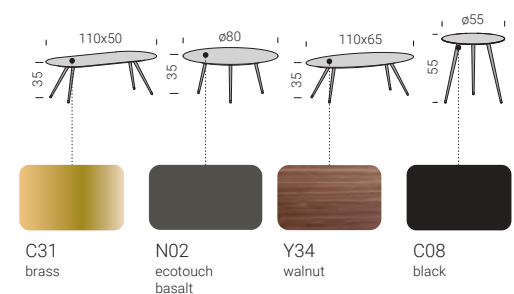

27/SPILLO

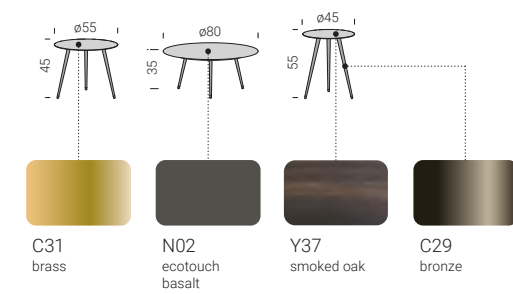

CONTRAPPESO pg. 340

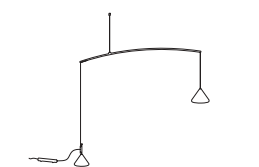

# SINTESI



SEMPLICITÀ COSTRUTTIVA ED ESSENZA DEI MATERIALI DANNO VITA AL TAVOLO ALLUNGABILE "SINTESI". IL TELAIO È IN ACCIAIO PER CONSENTIRE SEZIONI RIBASSATE E MANTENERE PERFORMANCE DI ALLUNGO SINO A 300 CM. IL TOP È IN HPL E I COMPONENTI INTERNI SONO IN ALLUMINIO, OTTONE E ACCIAIO INOX, CIÒ RENDE COMPATIBILE IL TAVOLO ANCHE IN OUTDOOR.

Simple construction and the essence of materials bringing a "Sintesi" extendable table to life. The steel frame allows for lowered sections and maintains performance up to a length of 300 cm. The top is in HPL and the inner parts are in aluminium, brass and stainless steel, making the table compact for outdoor use.

La simplicité de construction et l'essence des matériaux donnent le jour à la table à rallonges "sintesi". La structure est en acier pour permettre des sections surbaissées et maintenir une performance d'allongement jusqu'à 300 cm. Le plateau est en HPL et les composants internes sont en aluminium, laiton et acier inox, ce qui rend la table compatible pour utilisation également en extérieur.

Die einfache Konstruktion und das Wesentliche der Materialien sind kennzeichnend für den ausziehbaren Tisch „sintesi“. Der Rahmen ist aus Stahl, um abgeflachte Querschnitte und Längen von max. 300 cm zu ermöglichen. Das Abschlussbord ist aus HPL und die Innenteile sind aus Aluminium, Messing und Edelstahl, dadurch ist der Tisch auch für Outdoor geeignet.

Su construcción sencilla y la esencia de sus materiales dan vida a la mesa extensible "Sintesi". El bastidor es de acero para permitir secciones rebajadas y mantener su capacidad de extensión hasta 300 cm. El sobre es de HPL y los componentes interiores son de aluminio, latón y acero inoxidable, lo que hace que la mesa también se pueda usar en el exterior.



Disponibili riduzioni a misura  
Custom reductions available  
Réductions sur mesure disponibles  
Verkürzungen auf Maß erhältlich  
Disponibles reducciones a medida



Passacavo disponibile per tutti i top  
Cable gland available for all  
Topspasse-câble disponible pour tous les plateaux  
Kabeldurchlass für alle Abschlussborde verfügbar  
Pasacables disponible para todos los sobres



Uso in esterno riparato  
Use in a sheltered outdoor space  
Utilisation en extérieur, en espace abrité  
Verwendung in geschütztem Außenbereich  
Uso exterior protegido

## FINITURE/FINISHES



uso in esterno riparato  
protected outdoor use

### top tavolo / table top

legno massiccio solid wood	T01 rovere oak	T02 noce walnut	T03 iroko iroko	T04 iroko outdoor iroko outdoor	T05 rovere nero black oak
POLARIS®	L03 bianco white	L10 grigio chiaro light grey	L11 grigio scuro dark grey		
FENIX®	L08 grigio Londra London grey	L06 nero black			
HPL + legno HPL + wood	Y36 rovere oak	Y34 noce walnut	Y37 rovere affumicato smoked oak	Y40 frassino argilla clay ash	Y39 frassino nero black ash
HPL + metallo HPL + metal	C31 ottone brass	C32 ottone scuro dark brass	C35 inox inox	C36 inox scuro dark inox	
HPL + ecotouch	N01 sabbia sand	N02 basalto basalt			
HPL + cemento HPL + cement	D01 bianco calce lime white	D02 grigio Portland Portland grey	D03 nero black		
ceramica ceramic	S05 antracite anthracite	S06 nero black	S07 porfido porfido	S08 cardoso cardoso	

### telaio / structure

acciaio verniciato painted steel	C12 bianco white	C21 seta silk	C23 corda ecru	C30 ghisa cast-iron	C14 antracite anthracite
	C08 nero black	C18 verde green	C26 corten corten	C29 bronzo bronze	C37 rame copper
	C38 titanio titanium				

## DIMENSIONI/DIMENSIONS



verificare a listino geometrie e finiture  
check geometries and finishes in the price list

	120/140/160/180/200/220/240/300 x 78 200/220/240/300 x 98 200/220/240/300 x 120		78 x 78 90 x 90 98 x 98 120 x 120 140 x 140 158 x 158
	90/110/130/150/160/180/200/260 x 36		
	120/140/160/180/200 x 78 200/220/240/300 x 98 200/220/240/300 x 120		78 x 78 90 x 90 98 x 98 120 x 120 140 x 140 158 x 158
	90/110/130/150/160/180/200/260 x 36		
	tavoli allungabili extendable tables		130(180)/160(240) x 78 130(180)/160(240)/200(300) x 98 200(300) x 98
	panche allungabili extendable benches		90(140)/120(200)/160(260) x 36
	120/140/160/180 x 140 120/140/160/180 x 158		scrittoi writing desks 100/120/140/160 x 65



01/SINTESI

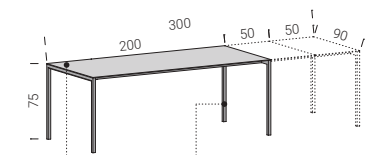

L06  
FENIX®  
black



C08  
black



SINTESI

- Apertura allunghe
- Opening of extensions
- Ouverture de rallonges
- Öffnung verlängerungsstücke
- Apertura de la extensión



02/SINTESI

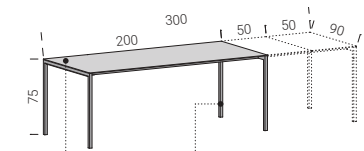

Y34  
walnut



C08  
black

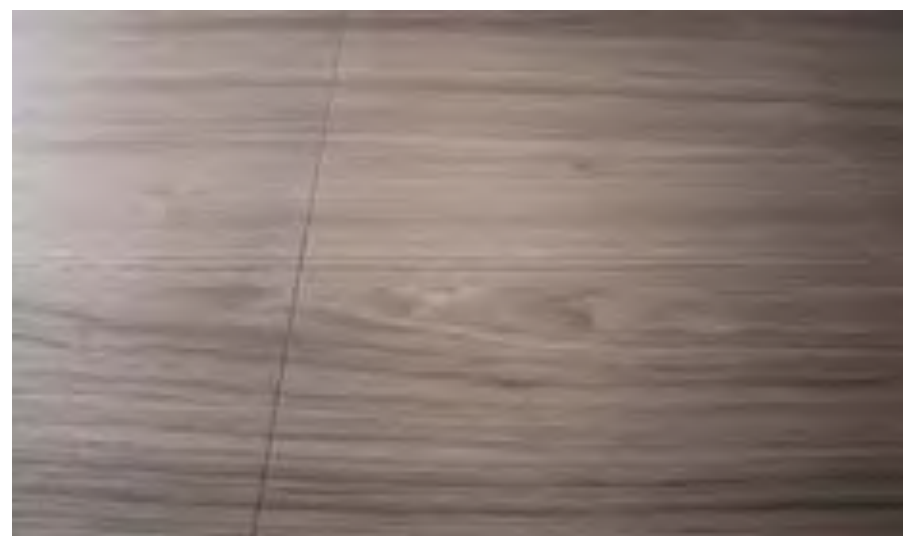

03/SINTESI

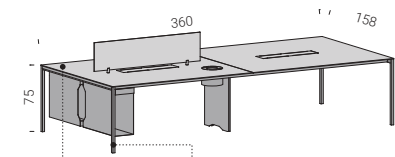

ATELIER pg. 46

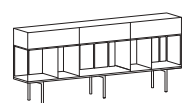



04/SINTESI

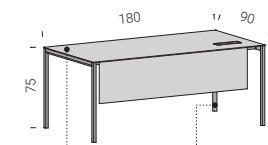

L11  
POLARIS®  
dark grey



C08  
black



05/SINTESI

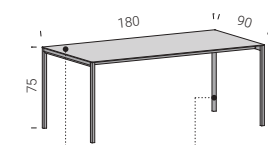

L10  
POLARIS®  
light grey



C30  
cast-iron



# ST35



AD INTERRUPIRE IL RIGORE DELLA FORMA RETTANGOLARE, LA LIEVE RAGGIATURA AI VERTICI DEL TOP FUNGE DA RACCORDO GEOMETRICO TRA ESSO E LA BASE IN ACCIAIO, E CONFERISCE AL TAVOLO ARMONIA E COMPATTEZZA DI FORMA. ST35 È DISPONIBILE IN VERSIONE FISSA E ALLUNGABILE; PER LA VERSIONE FISSA SONO DISPONIBILI 8 CATEGORIE DI FINITURE TOP, MENTRE PER I BASAMENTI LA SCELTA È TRA 11 COLORAZIONI A POLVERI.

Interrupting the rigour of the rectangular shape, the slight rounding at the corners of the top acts as a geometric connection between the top and the steel base and makes the table harmonic and compact. ST35, in the fixed and extendible version; for the fixed version there are 8 types of finish available for the top, while for the base there is a choice of 11 powder coated colours.

Pour interrompre la rigueur de la forme rectangulaire, le léger rayonnage aux sommets du plateau agit comme une connexion géométrique entre celui-ci et le socle en acier, conférant harmonie et compacité des formes à la table. ST35 est disponible en version fixe et extensible; il est possible de choisir parmi 8 catégories de finitions de plateau pour la version fixe, tandis que 11 couleurs de poudre sont disponibles pour les socles.

Zur Unterbrechung der Strenge der rechteckigen Form dient die leichte Strahlenform an den Enden der Tischplatte als geometrische Verbindung zwischen der Tischplatte und dem Sockel aus Eisen und verleiht dem Tisch Harmonie und Kompaktheit in der Form. ST35 ist in fester und ausdehnbarer Version verfügbar; für die feste Version sind 8 Beschichtungskategorien der Tischplatte verfügbar, während für das Untergestell zwischen 11 Pulverfärbungen gewählt werden kann.

Para interrumpir el rigor de la forma rectangular, el ligero radio de los vértices del tablero actúa como vínculo geométrico entre éste y la base de acero, dando a la mesa armonía y compacidad de formas. La ST35 está disponible en versión fija y extensible; para la versión fija hay 8 categorías de acabados para el tablero, mientras que para la base se puede elegir entre 11 colores con recubrimiento pulverizado.



Disponibili riduzioni a misura  
Custom reductions available  
Réductions sur mesure disponibles  
Verkürzungen auf Maß erhältlich  
Disponibles reducciones a medida



Passacavo disponibile per tutti i top  
Cable gland available for all  
Topspasse-câble disponible pour tous les plateaux  
Kabeldurchlass für alle Abschlussborde verfügbar  
Pasacables disponible para todos los sobres



Usato in esterno riparato  
Use in a sheltered outdoor space  
Utilisation en extérieur, en espace abrité  
Verwendung in geschütztem Außenbereich  
Uso exterior protegido

## FINITURE/FINISHES



uso in esterno riparato  
protected outdoor use

### top tavolo / table top

	legno massiccio solid wood	T01 rovere oak	T02 noce walnut	T03 iroko iroko	T04 iroko outdoor iroko outdoor	T05 rovere nero black oak
	POLARIS®	L03 bianco white	L10 grigio chiaro light grey	L11 grigio scuro dark grey		
	FENIX®	L08 grigio Londra London grey	L06 nero black			
	HPL + legno HPL + wood	Y36 rovere oak	Y34 noce walnut	Y37 rovere affumicato smoked oak	Y40 frassino argilla clay ash	Y39 frassino nero black ash
	HPL + metallo HPL + metal	C31 ottone brass	C32 ottone scuro dark brass	C35 inox inox	C36 inox scuro dark inox	
	HPL + ecotouch	N01 sabbia sand	N02 basalto basalt			
	HPL + cemento HPL + cement	D01 bianco calce lime white	D02 grigio Portland Portland grey	D03 nero black		
	ceramica ceramic	S05 antracite anthracite	S06 nero black	S07 porfido porfido	S08 cardoso cardoso	

### telaio / structure

	acciaio verniciato painted steel	C12 bianco white	C21 seta silk	C23 corda ecru	C30 ghisa cast-iron	C14 antracite anthracite
		C08 nero black	C18 verde green	C26 corten corten	C29 bronzo bronze	C37 rame copper
		C38 titanio titanium				

## DIMENSIONI/DIMENSIONS



verificare a listino geometrie e finiture  
check geometries and finishes in the price list

	120/140/160/180/200 x 78 120/140/160/180/200/220/240/300 x 90 200/220/240/300 x 98 200/220/240/300 x 120		78 x 78 90 x 90 98 x 98 120 x 120 140 x 140 158 x 158
	90/110/130/150/160/180/200/260 x 36		
	120/140/160/180/200 x 78 120/140/160/180/200/220/240/300 x 90 200/220/240/300 x 98 200/220/240/300 x 120		78 x 78 90 x 90 98 x 98 120 x 120 140 x 140 158 x 158
	90/110/130/150/160/180/200/260 x 36		
	tavoli allungabili extendable tables		130(180)/160(240) x 78 130(180)/160(240)/200(300) x 90 200/300 x 98
	panche allungabili extendable benches		90(140)/120(200)/160(260) x 36
	120/140/160/180 x 140 120/140/160/180 x 158		scrivitoi writing desks 100/120/140/160 x 65

05/ST35

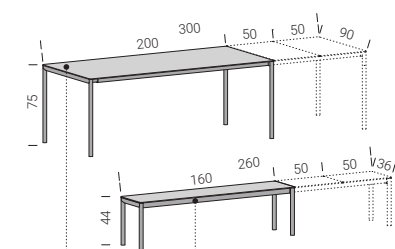

Y39  
black ash



C30  
cast-iron

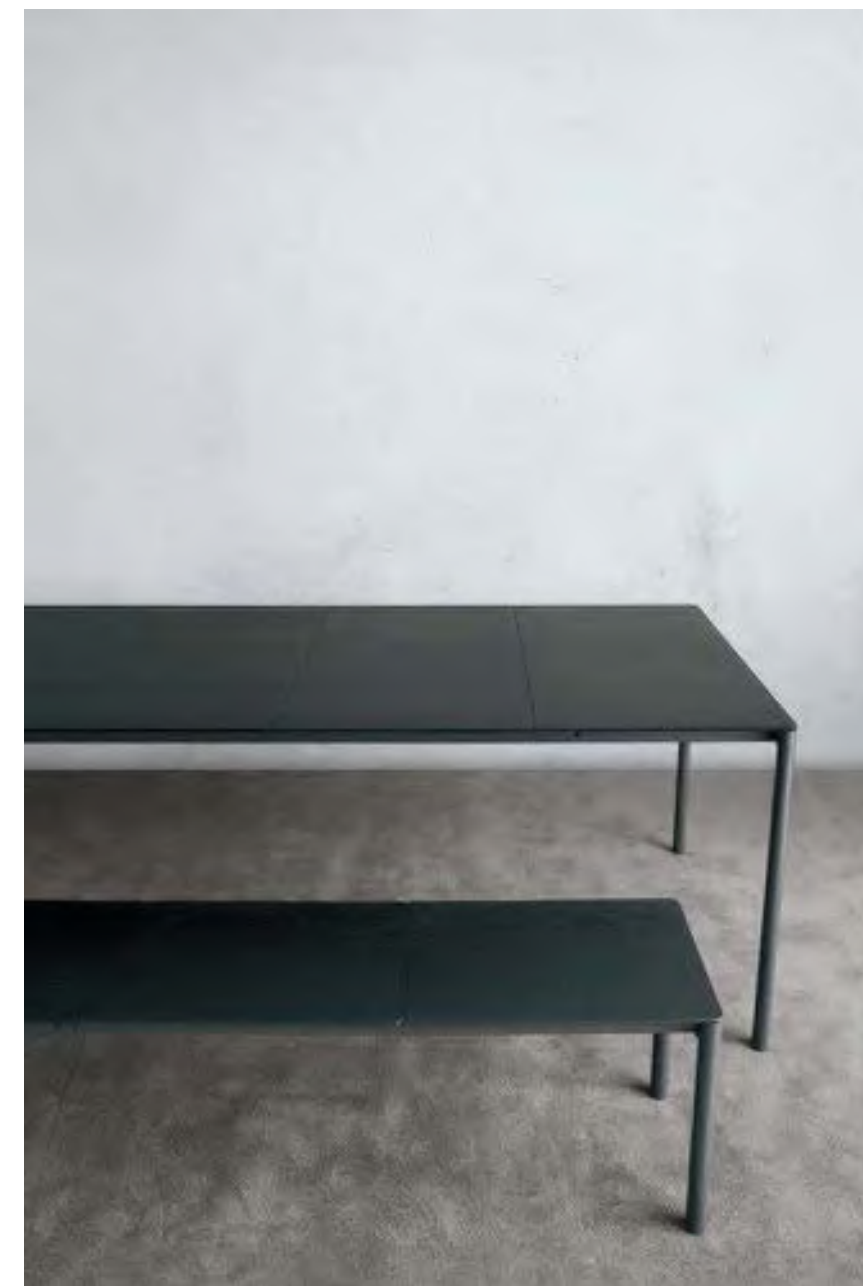

- ST35
- Apertura allunghe
  - Opening of extensions
  - Ouverture de rallonges
  - Öffnung verlängerungsstücke
  - Apertura de la extensión

02/ST35

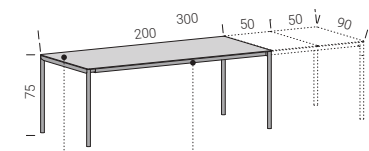

Y37  
smoked oak



C30  
cast-iron



ECH3 pg. 302



MONOLITH pg. 74

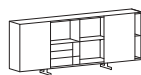





O1/ST35

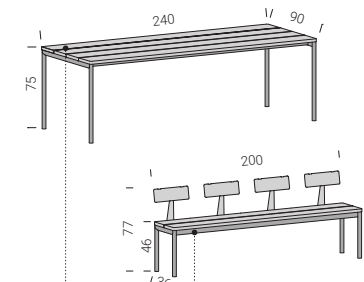

T04  
solid wood  
iroko outdoor



C08  
black



#### BENCHES

- Schienale flessibile
- Flexible backrest
- Dossier flexible
- Flexible rückenlehne
- Respaldo flexible



ATELIER

pg. 46





03/ST35

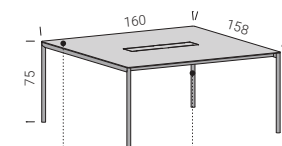

N02  
ecotouch  
basalt



C30  
cast-iron

ECH4 pg. 308



ATELIER pg. 46

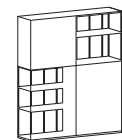

CONTRAPPESO pg. 340

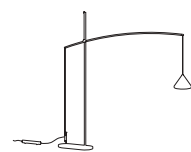

ST35

- ▶ Passacavi tavolo studio
- ▶ Office desk cable sleeve
- ▶ Passe-câbles pour table de bureau
- ▶ Kabeldurchgang bürotisch
- ▶ Pasacables mesa de trabajo



O4/ST35

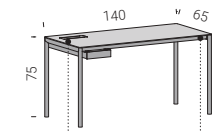

Y40  
clay ash

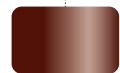

C37  
copper



ST35

- ▶ Passacavi scrittoio
- ▶ Writing desk cable sleeve
- ▶ Passe-câbles pour bureau
- ▶ Kabeldurchgang schreibitisch
- ▶ Pasacables escritorio



# IPE



UNA COLLEZIONE PROGETTATA PER COSTRUIRE TAVOLI DI GRANDI DIMENSIONI, LA SEZIONE AD IPE IN ACCIAIO UTILIZZATA PER IL SUPPORTO DEI TOP TAVOLI CONFERISCE GRANDE RIGIDITÀ E CONSENTE DI NASCONDERE I CAVI DI ALIMENTAZIONE DI UNITÀ MULTIMEDIALI DAL TOP ALLA PARTE INFERIORE DEL SUPPORTO. I TOP POSSONO ESSERE ACCOSTATI PER DARE VITA AD UN SISTEMA TAVOLI CON DIMENSIONI A PROGETTO.

This is a collection that has been designed in order to create large tables, the IPE section in steel used to support the table tops provides great sturdiness and allows the power cables from multimedia devices to be concealed from the top to the bottom of the support. The table tops can be combined in order to give life to a custom-sized table system.

Une collection conçue pour construire des tables de grandes dimensions, la section en IPE d'acier utilisée pour le support des plateaux de table fournit une grande rigidité et permet de cacher les câbles d'alimentation d'unités multimédias, du plateau à la partie inférieure du support. Les plateaux peuvent être combinés pour créer un système de tables avec des dimensions selon le projet.

Bei unserer Kollektion von großflächigen, stabilen Tischen werden IPE-Stahlprofile als Stütze für die Tischplatte verwendet, denn sie gewährleisten eine ausgezeichnete Standfestigkeit und ermöglichen zudem eine versteckte Kabelführung von multimedialen Geräten auf der Platte bis zum unteren Teil des Gestells. Die Platten können aneinandergeschoben und kombiniert werden, um ein beliebig großes Tischsystem zu kreieren.

Una colección diseñada para construir mesas de gran tamaño: el perfil IPE de acero utilizado para el soporte de las encimeras de las mesas, ofrece una rigidez considerable y permite ocultar los cables de alimentación de unidades multimedia desde la encimera hasta la parte inferior del soporte. Las encimeras pueden colocarse una al lado de la otra para generar un sistema de mesas con tamaños conformes a diseño.



Disponibili riduzioni a misura  
Custom reductions available  
Réductions sur mesure disponibles  
Verkürzungen auf Maß erhältlich  
Disponibles reducciones a medida



Passacavo disponibile per tutti i top  
Cable gland available for all  
Topspasse-câble disponible pour tous les plateaux  
Kabeldurchlass für alle Abschlussborde verfügbar  
Pasacables disponible para todos los sobres



Possibilità di affiancamento  
Possibility to place by side  
Possibilité d'association  
Aufstellung nebeneinander möglich  
Posibilidad de colocarse uno al lado del otro

## FINITURE/FINISHES

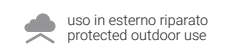

### top tavolo / table top

	legno massiccio solid wood					
	POLARIS®					
	FENIX®					
	HPL + legno HPL + wood					
	HPL + metallo HPL + metal					
	HPL + ecotouch					
	HPL + cemento HPL + cement					
	ceramica ceramic					

### telaio / structure

	acciaio verniciato painted steel					

## DIMENSIONI/DIMENSIONS



	180/200/220/240/260/280/300 x 90 200/220/240/260/280/300 x 100 220/240/260/280/300/360 x 120
	400/440/480/520/560 x 100 400/440/480/520/560 x 120
	200/220/240/260/280/300 x 105 220/240/260/280/300/360 x 125
	400/440/480/520/560 x 105 400/440/480/520/560 x 125
	180/200/220/240/260/280/300 x 90 200/220/240/260/280/300 x 100 220/240/260/280/300/360 x 120

01/IPE

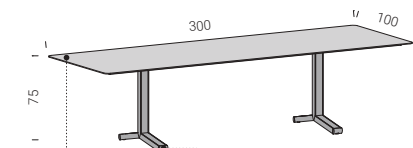

Y39  
black ash



C08  
black



IPE

- Cavi nascosti
- Hidden cables
- Câbles cachés
- Versteckte kabel
- Cables escondidos



03/IPE

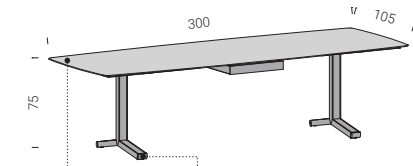

Y40  
clay ash

C29  
bronze





02/IPE

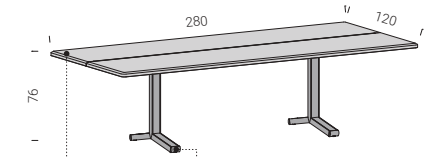

T02  
solid wood  
walnut



C08  
black



ATELIER pg. 46

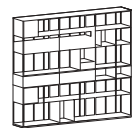

# HAMMER

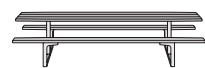

PROGETTATO SENZA COMPROMESSI PER UN IMPIEGO OUTDOOR, È COMUNQUE DISPONIBILE NELLE FINITURE NOCE E ROVERE MASSICCIO PER L'INSERIMENTO INDOOR. PER LA VERSIONE OUTDOOR IL TOP E LE SEDUTE SONO IN IROKO TRATTATO CON OLIO NATURALE, IL TELAIO È IN ACCIAIO CORTEN, O ACCIAIO VERNICIATO A POLVERI, GLI ELEMENTI DI CONNESSIONE SONO IN ACCIAIO INOX E OTTONE.

Designed without compromise for outdoor use, it is available in solid walnut and oak finishes for indoor use. For the outdoor version, the top and the chairs are in Iroko treated with natural oil, the frame is in Corten steel or powder painted steel. The joinery elements are in stainless steel or brass.

Conçu sans compromis pour une utilisation en extérieur, il est toutefois disponible dans les finitions noyer et chêne rouvre massif pour l'insertion d'intérieur. Pour la version d'extérieur, le plateau et les assises sont en Iroko traité avec de l'huile naturelle, la structure est en acier Corten, ou en acier verni par poudres, les éléments de connexion sont en acier inox et laiton.

Kompromissloser Entwurf für den Outdoor-Einsatz, steht jedoch auch als Indoor-Lösung mit Endbehandlung Nussbaum und Massiveiche zur Verfügung. Für die Outdoor-Version sind Abschlussbord und Sitze aus mit natürlichem Öl behandeltem Iroko, der Rahmen ist aus Corten-Stahl oder pulverlackiertem Stahl und die Verbindungsstücke sind aus Edelstahl und Messing.

Diseñada para usarla sin problemas en el exterior, también está disponible en los acabados nogal y roble macizo para su uso en el interior. Para la versión de exterior el sobre y los asientos son de iroko tratado con aceite natural, el bastidor es de acero corten, o acero tratado con barniz en polvo, los elementos de unión son de acero inoxidable y latón.



Disponibili riduzioni a misura  
Custom reductions available  
Réductions sur mesure disponibles  
Verkürzungen auf Maß erhältlich  
Disponibles reducciones a medida



Uso in esterno  
Outdoor use  
Utilisation en extérieur  
Verwendung im Außenbereich  
Uso en exteriores



Piedini regolabili in acciaio  
Adjustable feet in steel  
Pieds réglables en acier  
Regulierbaren Stahlfüßchen  
Patas regulables de acero

## FINITURE/FINISHES



uso in esterno  
full outdoor use

### top tavolo / table top

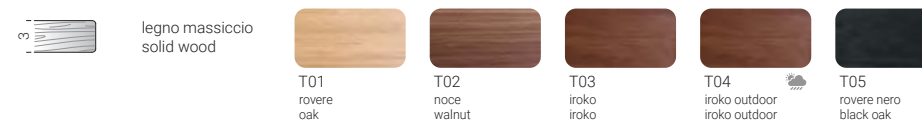

### telaio / structure



## DIMENSIONI/DIMENSIONS



verificare a listino geometrie e finiture  
check geometries and finishes in the price list

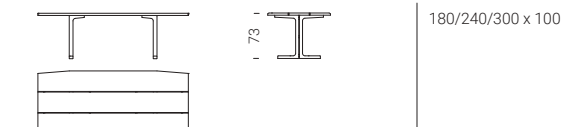
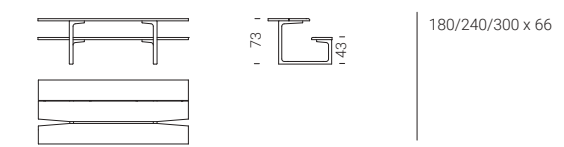
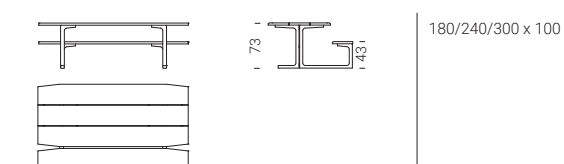
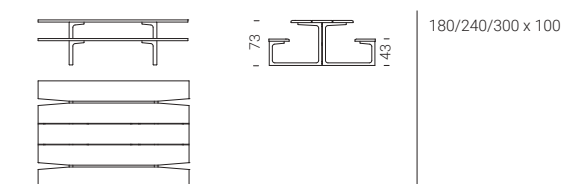

04/HAMMER

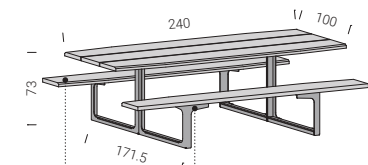

T04  
solid wood  
iroko outdoor



C27  
corten outdoor



05/HAMMER

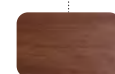
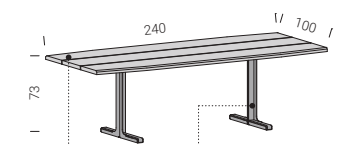

T04  
solid wood  
iroko outdoor



C30  
cast-iron



06/HAMMER

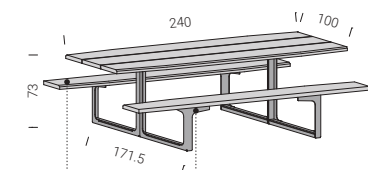

T02  
solid wood  
walnut



C08  
black



T7



GRAZIE ALLA TECNOLOGIA DI PIEGATURA TRIDIMENSIONALE DEI PROFILI È STATO POSSIBILE REALIZZARE UN SISTEMA TAVOLI CHE OFFRE MOLTEPLICI GRADI DI LIBERTÀ. IL TELAIO LEGGERO MA RESISTENTE SUPPORTA TAVOLI DA 160 A 300CM DI LUNGHEZZA, INOLTRE ACCOGLIE 5 TIPOLOGIE DI GEOMETRIE TOP E RENDE POSSIBILE ANCHE LA RIDUZIONE A MISURA.

Thanks to the 3D profile bending technology, it has been possible to create a table system that provides multiple degrees of freedom. The light yet resistant frame supports tables between 160 and 300cm long; moreover, it can accommodate 5 types table top profiles and makes custom reduction possible.

Grâce à la technologie de pliage tridimensionnel des profils, il a été possible de réaliser un système de tables qui offre de nombreux niveaux de liberté. Le châssis léger, mais résistant, supporte des tables de 160 à 300 cm de longueur, en outre il accueille 5 typologies de géométries de plateaux et permet aussi la réduction sur mesure.

Dank eines technologisch ausgefeilten, dreidimensionalen Biegeverfahrens erhält man Profile für ein Tischsystem mit einem breiten Spektrum an freien Gestaltungsmöglichkeiten. Leichte, formstabile Gestelle tragen Tischplatten von 160 bis 300 cm Länge, in fünf verschiedenen Ausformungen und Größen, wobei auch die Verkürzung nach Maß vorgesehen ist.

Gracias a la tecnología de doblado tridimensional de los perfiles, se ha podido realizar un sistema de mesas que ofrece múltiples niveles de libertad. El bastidor ligero pero resistente, soporta mesas de 160 a 300cm de largo: además, cuenta con 5 tipos de geometrías para la encimera y también permite la reducción a medida.

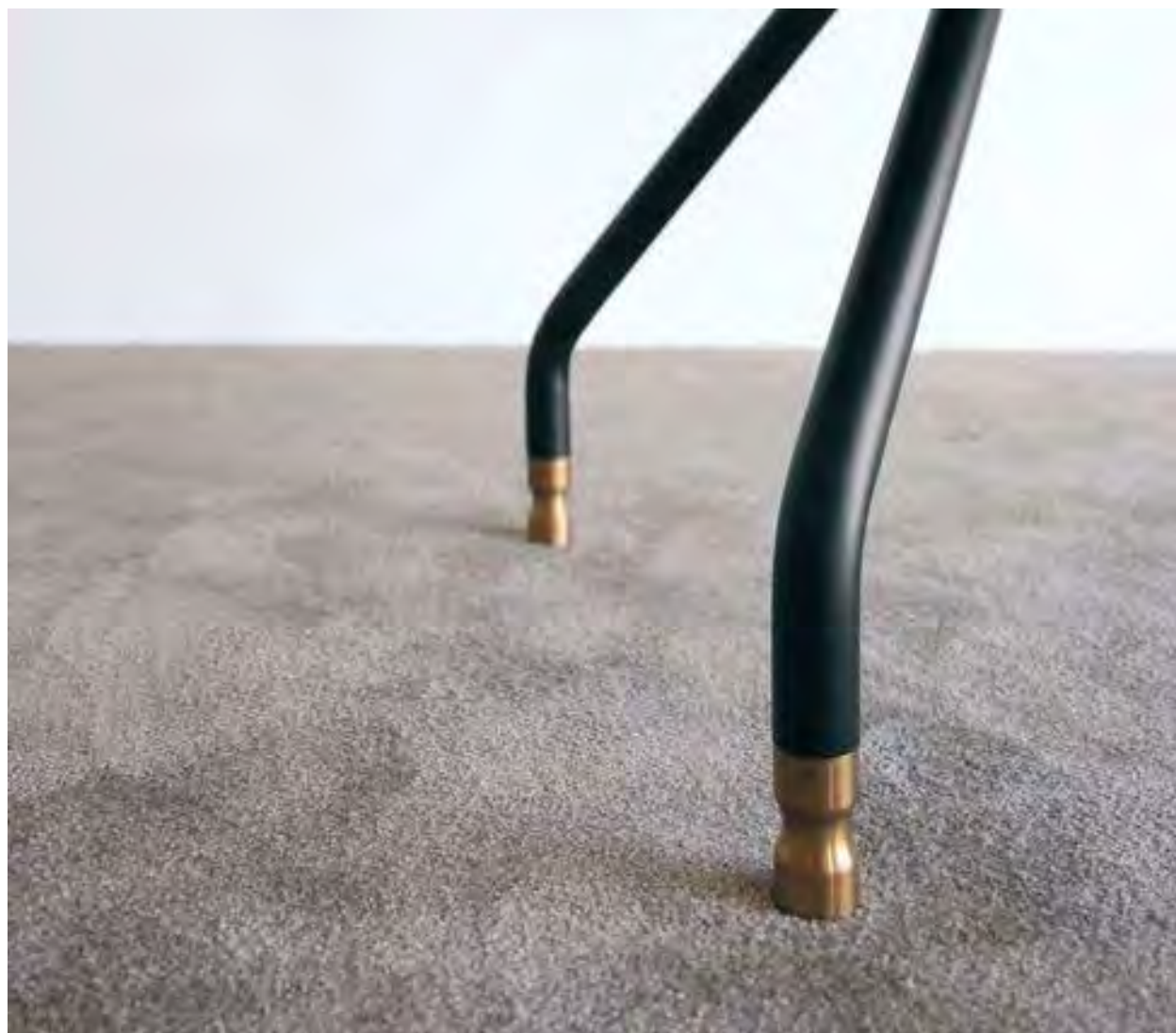

Disponibili riduzioni a misura  
Custom reductions available  
Réductions sur mesure disponibles  
Verkürzungen auf Maß erhältlich  
Disponibles reducciones a medida



Passacavo disponibile per tutti i top  
Cable gland available for all  
Topspasse-câble disponible pour tous les plateaux  
Kabeldurchlass für alle Abschlussborde verfügbar  
Pasacables disponible para todos los sobres



Piede in ottone, ottone brunito o verniciatura a polveri  
foot in brass, dark brass or powder coated  
pied en laiton, laiton bruni ou thermolaqué  
Fuß aus Messing, Messing brüniert oder pulverbeschichtet  
pie en latón, latón bruñido o con recubrimiento de polvo



EXTENDABLE TABLE SYSTEM  
registered community design

## FINITURE/FINISHES



uso in esterno riparato  
protected outdoor use

### top tavolo / table top

	legno massiccio solid wood	T01 rovere oak	T02 noce walnut	T03 iroko iroko	T04 iroko outdoor iroko outdoor	T05 rovere nero black oak
	POLARIS®	L03 bianco white	L10 grigio chiaro light grey	L11 grigio scuro dark grey		
	FENIX®	L08 grigio Londra London grey	L06 nero black			
	HPL + legno HPL + wood	Y36 rovere oak	Y34 noce walnut	Y37 rovere affumicato smoked oak	Y40 frassino argilla clay ash	Y39 frassino nero black ash
	HPL + metallo HPL + metal	C31 ottone brass	C32 ottone scuro dark brass	C35 inox inox	C36 inox scuro dark inox	
	HPL + ecotouch	N01 sabbia sand	N02 basalto basalt			
	HPL + cemento HPL + cement	D01 bianco calce lime white	D02 grigio Portland Portland grey	D03 nero black		
	ceramica ceramic	S05 antracite anthracite	S06 nero black	S07 porfido porfido	S08 cardoso cardoso	

### telaio / structure

	acciaio verniciato painted steel	C12 bianco white	C21 seta silk	C23 corda ecru	C30 ghisa cast-iron	C14 antracite anthracite
		C08 nero black	C18 verde green	C26 corten corten	C29 bronzo bronze	C37 rame copper
		C38 titanio titanium				

## DIMENSIONI/DIMENSIONS



verificare a listino geometrie e finiture  
check geometries and finishes in the price list

		160/180/200/220/240 x 90 180/200/220/240/300 x 98
		180/200/220/240 x 90 180/200/220/240/300 x 98
		180/200/220/240/300 x 98 180/200/220/240/300 x 105
		160 x 85 180 x 95 200 x 105 220 x 115 248 x 128
		180/200/220/240/300 x 100
		tavoli allungabili extendable tables 170(260)/200(290)/230(320) x 90 170(260)/200(290)/230(320) x 98

03/T7

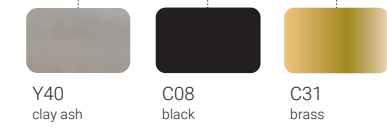
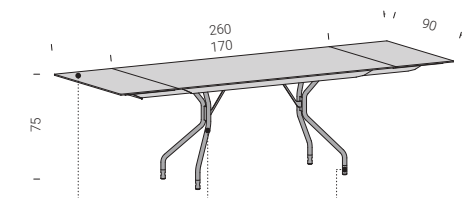

ECH3 pg. 302



EWS pg. 26

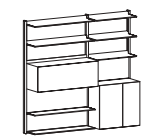

CONTRAPPESO pg. 340

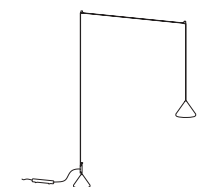

T7

- Apertura allunghe
- Opening of extensions
- Ouverture de rallonges
- Öffnung verlängerungsstücke
- Apertura de la extensión



01/T7

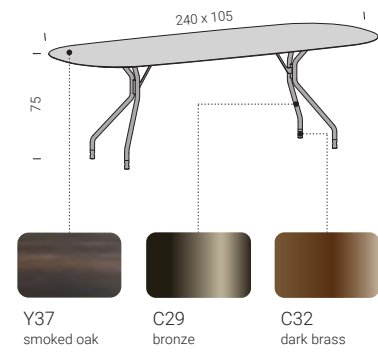



# T8

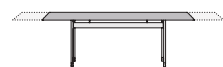

UN PROGETTO DI LE CORBUSIER DEL 1928 HA ISPIRATO IL DESIGN DI QUESTO SISTEMA TAVOLI. I NUOVI MATERIALI HANNO CONSENTITO UN RIDISEGNO ALL'INSEGNA DELLA LEGGEREZZA E DI UNA GRANDE LIBERTÀ DI CONFIGURAZIONE. E' UNA COLLEZIONE DI TAVOLI E PANCHE DISPONIBILI NELLA VERSIONE FISSA E ALLUNGABILE.

A 1928 Le Corbusier project inspired the design of this table system. New materials have enabled a re-designing of this project in pursuit of lightness along with a great freedom of configuration. This is a collection of tables and benches available in both fixed and extendable versions.

Un projet de Le Corbusier de 1928 a inspiré le design de ce système de tables. Les nouveaux matériaux ont permis de le redessiner à l'enseigne de la légèreté et d'une grande liberté de configuration. C'est une collection de tables et de bancs disponibles dans la version fixe et extensible.

Ein Entwurf von Le Corbusier aus dem Jahr 1928 diente als Anregung für das Design dieses Tischsystems. Innovative Materialien prägen das aktualisierte Konzept, bei dem Leichtigkeit und eine große Gestaltungsfreiheit im Vordergrund stehen. Eine Kollektion von Tischen und Bänken, die als feste oder ausziehbare Version zur Verfügung steht.

Un diseño de Le Corbusier de 1928, inspiró el diseño de este sistema de mesas. Los nuevos materiales han permitido realizar un nuevo diseño sobre la base del antiguo, caracterizado por ligereza y gran libertad de configuración. Es una colección de mesas y banquetillos disponibles en la versión fija y extensible.



Disponibili riduzioni a misura  
Custom reductions available  
Réductions sur mesure disponibles  
Verkürzungen auf Maß erhältlich  
Disponibles reducciones a medida



Passacavo disponibile per tutti i top  
Cable gland available for all  
Topspasse-câble disponible pour tous les plateaux  
Kabeldurchlass für alle Abschlussborde verfügbar  
Pasacables disponible para todos los sobres



Piede in ottone, ottone brunito o verniciatura a polveri  
foot in brass, dark brass or powder coated  
pied en laiton, laiton bruni ou thermolaqué  
Fuß aus Messing, Messing brüniert oder pulverbeschichtet  
pie en latón, latón bruñido o con recubrimiento de polvo



EXTENDABLE TABLE SYSTEM registered community design

## FINITURE/FINISHES



uso in esterno riparato  
protected outdoor use

### top tavolo / table top

0.5	legno massiccio solid wood	T01 rovere oak	T02 noce walnut	T03 iroko iroko	T04 iroko outdoor iroko outdoor	T05 rovere nero black oak
0.6	POLARIS®	L03 bianco white	L10 grigio chiaro light grey	L11 grigio scuro dark grey		
0.6	FENIX®	L08 grigio Londra London grey	L06 nero black			
0.7	HPL + legno HPL + wood	Y36 rovere oak	Y34 noce walnut	Y37 rovere affumicato smoked oak	Y40 frassino argilla clay ash	Y39 frassino nero black ash
0.7	HPL + metallo HPL + metal	C31 ottone brass	C32 ottone scuro dark brass	C35 inox inox	C36 inox scuro dark inox	
0.7	HPL + ecotouch	N01 sabbia sand	N02 basalto basalt			
0.7	HPL + cemento HPL + cement	D01 bianco calce lime white	D02 grigio Portland Portland grey	D03 nero black		
0.8	ceramica ceramic	S05 antracite anthracite	S06 nero black	S07 porfido porfido	S08 cardoso cardoso	

### telaio / structure

1.3	acciaio verniciato painted steel	C12 bianco white	C21 seta silk	C23 corda ecru	C30 ghisa cast-iron	C14 antracite anthracite
		C08 nero black	C18 verde green	C26 corten corten	C29 bronzo bronze	C37 rame copper
		C38 titanio titanium				

## DIMENSIONI/DIMENSIONS



verificare a listino geometrie e finiture  
check geometries and finishes in the price list

	120/160/180/200 x 78 120/160/180/200/220/240 x 90 180/200/220/240/300 x 98		120/140/160/180 x 36 200/220/240/300 x 36
	180/200 x 78 180/200/220/240 x 90 180/200/220/240/300 x 98		
	180/200/220/240/300 x 98 180/200/220/240/300 x 105		
	160 x 85 180 x 95 200 x 105 220 x 115 248 x 128		
	78 x 78 90 x 90 98 x 98 120 x 120 140 x 140		120 x 120 140 x 140
	ø 128 ø 140 ø 160		
	180/200/220/240/300 x 100 180/200/220/240/300 x 36		
	170(260)/200(290)/230(320) x 90 170(260)/200(290)/230(320) x 98		
	160(240)/200(280)/230(310) x 36		

05/T8

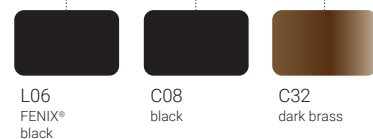
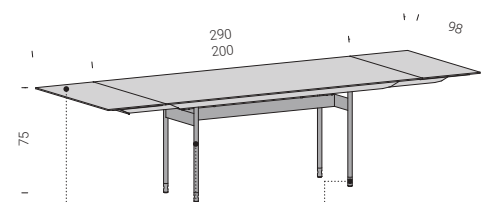

T8

- Apertura allunghe
- Opening of extensions
- Ouverture de rallonges
- Öffnung verlängerungsstücke
- Apertura de la extensión



01/T8

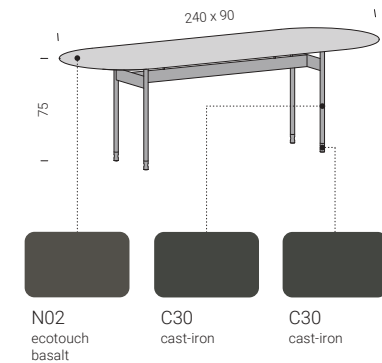

VIKING pg. 294



ATELIER pg. 46

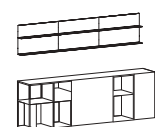

04/T8

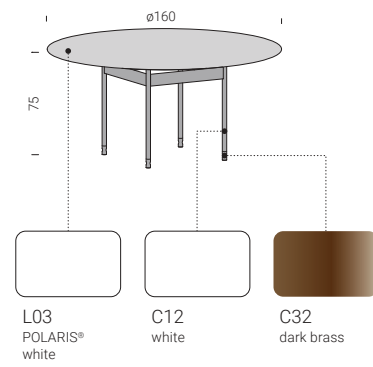

VIKING pg. 294



XY pg. 94

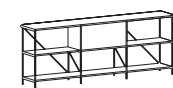

02/T8

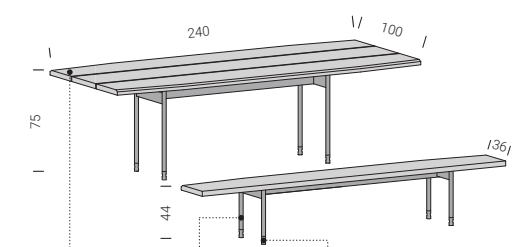

- T04 solid wood iroko outdoor
- C08 black
- C32 dark brass



ATELIER pg. 46

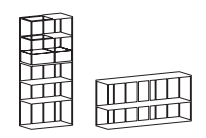

# T9

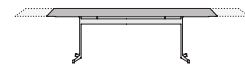

IL TAGLIO LASER SU ACCIAIO DI SPESSORE 8MM E LA PRESSO-PIEGATURA CONSENTONO DI RIDURRE AL MINIMO L'INGOMBRO DEL SUPPORTO AUMENTANDO LO SPAZIO UTILE ALLE SEDIE E DI CONSEGUENZA LA FRUIBILITÀ COMPLESSIVA DEL TAVOLO. T9 È DISPONIBILE IN VERSIONE FISSA E ALLUNGABILE. LA VERSIONE FISSA È CONFIGURABILE CON 8 GEOMETRIE DI TOP DISPONIBILI IN 8 CATEGORIE DI FINITURE, MENTRE PER I BASAMENTI LA SCELTA È TRA 11 COLORAZIONI A POLVERI.

Laser cutting on 8 mm thick steel and press-bending allow minimization of the overall size of the support, increasing the space for the chairs and, consequently, the overall use of the table. T9 is available in the fixed and extending version. The fixed version can have 8 geometries of top in 8 types of finish, while for the bases there is a choice of 11 powder coated colours.

La découpe au laser sur acier de 8 mm d'épaisseur et le pliage à la presse permettent de réduire les dimensions du support au minimum, augmentant ainsi l'espace utile aux assises pour utiliser pleinement la table. T9 est disponible en version fixe et extensible. La version fixe peut être configurée en choisissant parmi 8 formes de plateau, disponibles en 8 catégories de finitions, tandis que 11 couleurs de poudre sont disponibles pour les socles.

Das Laserschneiden auf 8 mm dickem Stahl und das Faltpressen ermöglichen es, die Größe der Stütze auf das Minimum zu reduzieren und so den brauchbaren Raum für die Stühle zu vergrößern und infolgedessen die Verwendbarkeit des Tisches zu optimieren. T9 ist in fester und ausdehnbarer Version verfügbar. Die feste Version kann mit 8 Tischplattenformen, verfügbar in 8 Beschichtungskategorien, konfiguriert werden, während für den Sockel zwischen 11 Pulverfärbungen gewählt werden kann.

El corte láser en acero de 8 mm de grosor y el plegado a presión permiten reducir al mínimo las dimensiones del soporte, lo que aumenta el espacio disponible para las sillas y, en consecuencia, la utilidad general de la mesa. La T9 está disponible en versión fija y extensible. La versión fija puede configurarse con 8 geometrías de tablero disponibles en 8 categorías de acabados, mientras que para las bases se puede elegir entre 11 colores con recubrimiento pulverizado.



Disponibili riduzioni a misura  
Custom reductions available  
Réductions sur mesure disponibles  
Verkürzungen auf Maß erhältlich  
Disponibles reducciones a medida



Passacavo disponibile per tutti i top  
Cable gland available for all  
Topspasse-câble disponible pour tous les plateaux  
Kabeldurchlass für alle Abschlussborde verfügbar  
Pasacables disponible para todos los sobres



Piedini regolabili in acciaio inox.  
Adjustable feet in stainless steel.  
Pieds réglables en acier inox.  
Regulierbaren Edelstahlfußchen.  
Patas regulables de acero inoxidable.



EXTENDABLE  
TABLE SYSTEM  
registered community  
design

## FINITURE/FINISHES



uso in esterno riparato  
protected outdoor use

### top tavolo / table top

0.3	legno massiccio solid wood	T01 rovere oak	T02 noce walnut	T03 iroko iroko	T04 iroko outdoor iroko outdoor	T05 rovere nero black oak
0.6	POLARIS®	L03 bianco white	L10 grigio chiaro light grey	L11 grigio scuro dark grey		
0.6	FENIX®	L08 grigio Londra London grey	L06 nero black			
0.7	HPL + legno HPL + wood	Y36 rovere oak	Y34 noce walnut	Y37 rovere affumicato smoked oak	Y40 frassino argilla clay ash	Y39 frassino nero black ash
0.7	HPL + metallo HPL + metal	C31 ottone brass	C32 ottone scuro dark brass	C35 inox inox	C36 inox scuro dark inox	
0.7	HPL + ecotouch	N01 sabbia sand	N02 basalto basalt			
0.7	HPL + cemento HPL + cement	D01 bianco calce lime white	D02 grigio Portland Portland grey	D03 nero black		
0.6	ceramica ceramic	S05 antracite anthracite	S06 nero black	S07 porfido porfido	S08 cardoso cardoso	

### telaio / structure

1.2.5	acciaio verniciato painted steel	C12 bianco white	C21 seta silk	C23 corda ecru	C30 ghisa cast-iron	C14 antracite anthracite
		C08 nero black	C18 verde green	C26 corten corten	C29 bronzo bronze	C37 rame copper
		C38 titanio titanium				

## DIMENSIONI/DIMENSIONS



verificare a listino geometrie e finiture  
check geometries and finishes in the price list

		120/160/180/200 x 78 120/160/180/200/220/240 x 90 180/200/220/240/300 x 98 200/220/240/300 x 110		
		180/200 x 78 180/200/220/240 x 90 180/200/220/240/300 x 98		
		180/200/220/240/300 x 98 180/200/220/240/300 x 105		
		160 x 85 180 x 95 200 x 105 220 x 115 248 x 128		
		120 x 120 140 x 140		120 x 120 140 x 140
		ø 128 ø 140 ø 160		
		180/200/220/240/300 x 100		scrittoi writing desks 100/120/140/160 x 65 160 x 78
		tavoli allungabili extendable tables 170(260)/200(290)/230(320) x 90 170(260)/200(290)/230(320) x 98		

04/T9

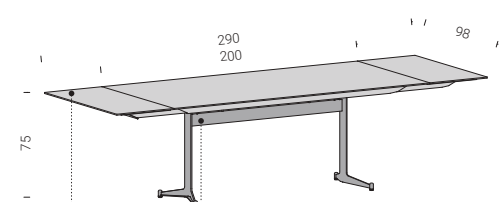

- L06 FENIX® black
- C08 black



ECH7 pg. 324



CONTRAPPESO pg. 340

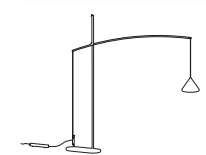

- T9
- Apertura allunghe
- Opening of extensions
- Ouverture de rallonges
- Öffnung verlängerungsstücke
- Apertura de la extensión

02/T9

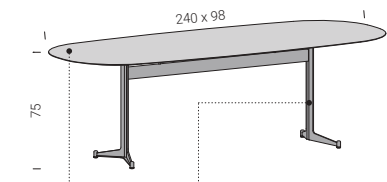

ECH6 pg. 318



CONTRAPPESO pg. 340

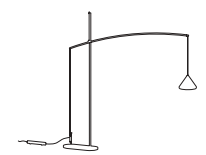



03/T9

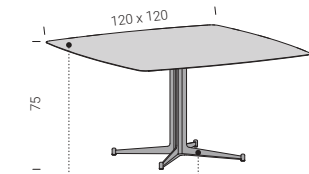

D01  
lime white



C30  
cast-iron



01/T9

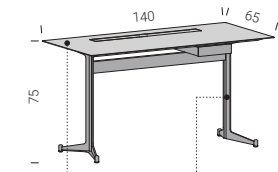

C32  
dark brass



C08  
black



# T10

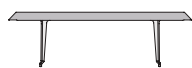

LA RICERCA DI JEAN PROUVÉ CON IL TAVOLO TRAPÈZE DEL 1950/54 HA ISPIRATO IL DESIGN DEL TAVOLO T10. I TERMINALI IN OTTONE O OTTONE BRUNITO PROTEGGONO IL BASAMENTO DA URTI ACCIDENTALI E GARANTISCONO STABILITÀ AL TAVOLO. T10, IN VERSIONE FISSA, È CONFIGURABILE CON 5 GEOMETRIE DI TOP DISPONIBILI IN 8 CATEGORIE DI FINITURE, MENTRE PER I BASAMENTI LA SCELTA È TRA 11 COLORAZIONI A POLVERI.

The research of Jean Prouvé with the 1950/54 Trapèze table has inspired the design of the T10 table. The brass or burnished brass ends protect the base against accidental impacts and guarantee the stability of the table. T10, in the fixed version, can have 5 geometries of top available in 8 types of finish, while for the bases there is a choice of 11 powder coated colours.

Les recherches de Jean Prouvé avec la table Trapèze de 1950/54 ont inspiré le design de la table T10. Les extrémités en laiton ou en laiton bruni protègent le socle contre les chocs accidentels et garantissent la stabilité de la table. T10, dans sa version fixe, peut être configurée en choisissant parmi 5 formes de plateau, disponibles en 8 catégories de finitions, tandis que 11 couleurs de poudre sont disponibles pour les socles.

Die Studien von Jean Prouvé mit dem Tisch Trapèze von 1950/54 haben das Design des Tisches T10 inspiriert. Die Endteile aus Messing und brüniertem Messing schützen das Untergestell vor Stößen und verleihen dem Tisch Stabilität. T10, in fester Version, kann mit 5 Tischplattenformen, verfügbar in 8 Beschichtungskategorien, konfiguriert werden, während für das Untergestell zwischen 11 Pulverfärbungen gewählt werden kann.

Las investigaciones de Jean Prouvé con la mesa Trapèze de 1950/54 inspiraron el diseño de la mesa T10. Los remates de latón o latón bruñido protegen la base de golpes accidentales y proporcionan estabilidad a la mesa. La versión fija de T10 puede configurarse con 5 geometrías de tablero disponibles en 8 categorías de acabados, mientras que la base está disponible en 11 colores con recubrimiento pulverizado.



Disponibili riduzioni a misura  
Custom reductions available  
Réductions sur mesure disponibles  
Verkürzungen auf Maß erhältlich  
Disponibles reducciones a medida



Passacavo disponibile per tutti i top  
Cable gland available for all  
Tops-passe-câble disponible pour tous les plateaux  
Kabeldurchlass für alle Abschlussborde verfügbar  
Pasacables disponible para todos los sobres



Piedini regolabili in acciaio inox.  
Adjustable feet in stainless steel.  
Pieds réglables en acier inox.  
Regulierbaren Edelstahlfüßchen.  
Patas regulables de acero inoxidable.

## FINITURE/FINISHES

uso in esterno riparato  
protected outdoor use

### top tavolo / table top

legno massiccio solid wood	T01 rovere oak	T02 noce walnut	T03 iroko iroko	T04 iroko outdoor iroko outdoor	T05 rovere nero black oak
POLARIS®	L03 bianco white	L10 grigio chiaro light grey	L11 grigio scuro dark grey		
FENIX®	L08 grigio Londra London grey	L06 nero black			
HPL + legno HPL + wood	Y36 rovere oak	Y34 noce walnut	Y37 rovere affumicato smoked oak	Y40 frassino argilla clay ash	Y39 frassino nero black ash
HPL + metallo HPL + metal	C31 ottone brass	C32 ottone scuro dark brass	C35 inox inox	C36 inox scuro dark inox	
HPL + ecotouch	N01 sabbia sand	N02 basalto basalt			
HPL + cemento HPL + cement	D01 bianco calce lime white	D02 grigio Portland Portland grey	D03 nero black		
ceramica ceramic	S05 antracite anthracite	S06 nero black	S07 porfido porfido	S08 cardoso cardoso	

### telaio / structure

acciaio verniciato painted steel	C12 bianco white	C21 seta silk	C23 corda ecru	C30 ghisa cast iron	C14 antracite anthracite
	C08 nero black	C18 verde green	C26 corten corten	C29 bronzo bronze	C37 rame copper
	C38 titanio titanium				

## DIMENSIONI/DIMENSIONS

verificare a listino geometrie e finiture  
check geometries and finishes in the price list

	120/160/180/200 x 78 120/160/180/200/220/240 x 90 180/200/220/240/300 x 98 200/220/240/300 x 110
	180/200 x 78 180/200/220/240 x 90 180/200/220/240/300 x 98
	180/200/220/240/300 x 98 180/200/220/240/300 x 105
	160 x 85 180 x 95 200 x 105 220 x 115 248 x 128
	180/200/220/240/300 x 100

02/T10

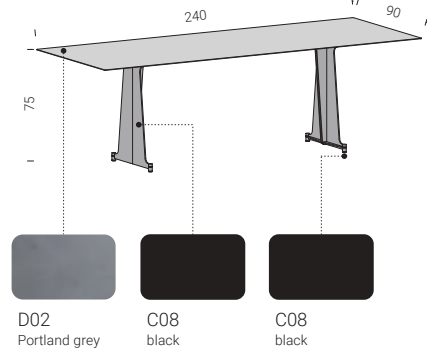

01/T10

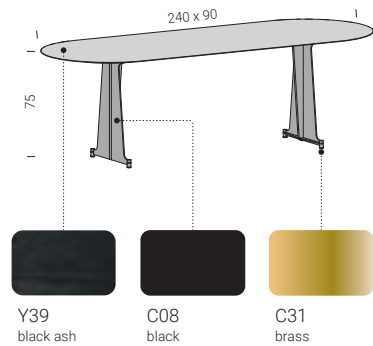

# T11



PROGETTARE UN TELAIO A TRALICCIO CI HA PERMESSO DI RIDURRE LE SEZIONI DEI PROFILI IN ACCIAIO AL MINIMO: SOLI 8 O 16 MM DI DIAMETRO, CHE UNA VOLTA PIEGATI E SALDATI, SUPPORTANO TAVOLI CON DIMENSIONI SINO A 300 CM. T11 È DISPONIBILE IN VERSIONE FISSA E ALLUNGABILE. LA VERSIONE FISSA È CONFIGURABILE CON 8 GEOMETRIE DI TOP DISPONIBILI E IN 8 CATEGORIE DI FINITURE, MENTRE PER I BASAMENTI LA SCELTA È TRA 11 COLORAZIONI A POLVERI.

The trellis frame has allowed us to minimize the sections of the steel profiles: just 8 or 16 mm in diameter which, once bent and welded, support tables of up to 300 cm. T11 is available in fixed and extendable version. The fixed version can have 8 geometries of top available in 8 types of finish, while for the bases there is a choice of 11 powder coated colours.

La conception d'un cadre en treillis a permis de réduire au minimum les sections des profilés en acier lesquels, avec seulement 8 ou 16 mm de diamètre, pliés et soudés, supportent des tables allant jusqu'à 300 cm. T11 est disponible en version fixe et extensible. La version fixe peut être configurée en choisissant parmi 8 formes de plateau, disponibles en 8 catégories de finitions, tandis que 11 couleurs de poudre sont disponibles pour les socles.

Der Entwurf eines Gitterrohrrahmens hat es uns ermöglicht, die Schnitte der Stahlprofile auf das Minimum zu reduzieren: nur 8 oder 16 mm Durchmesser, die nach dem Falten und dem Schweißen Tische mit einer Größe von bis zu 300 cm stützen. T11 ist in fester und ausdehnbarer Version verfügbar. Die feste Version kann mit 8 Tischplattenformen, verfügbar in 8 Beschichtungskategorien, konfiguriert werden, während für das Untergestell zwischen 11 Pulverfärbungen gewählt werden kann.

El diseño de un marco de celosía nos ha permitido reducir las secciones de los perfiles de acero al mínimo: sólo 8 o 16 mm de diámetro, que una vez doblados y soldados, soportan mesas de hasta 300 cm de tamaño. T11 está disponible en versión fija y extensible. La versión fija puede configurarse con 8 geometrías de tablero disponibles y en 8 categorías de acabados, mientras que para las bases se puede elegir entre 11 colores con recubrimiento pulverizado

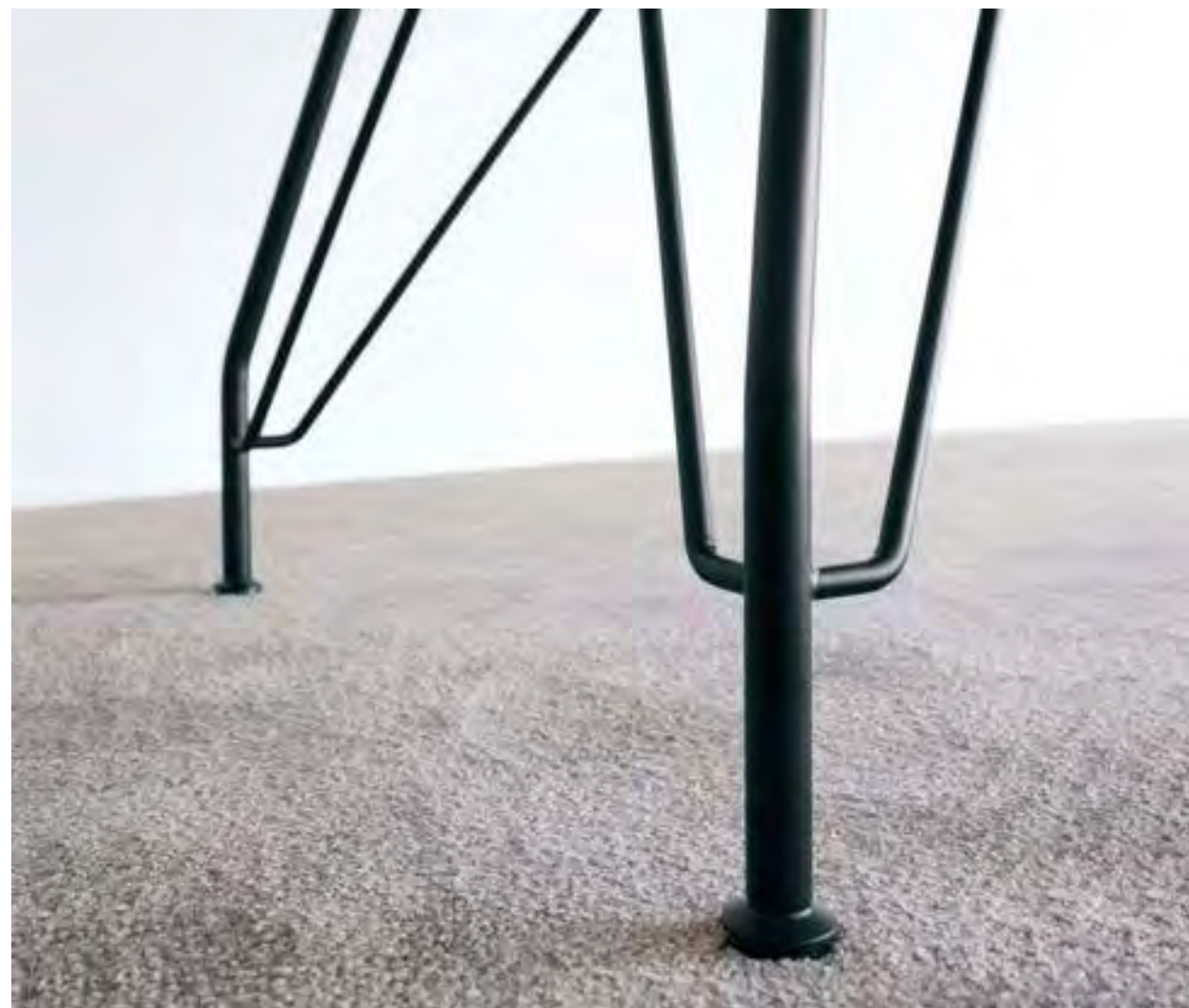

Disponibili riduzioni a misura  
Custom reductions available  
Réductions sur mesure disponibles  
Verkürzungen auf Maß erhältlich  
Disponibles reducciones a medida



Passacavo disponibile per tutti i top  
Cable gland available for all  
Topspasse-câble disponible pour tous les plateaux  
Kabeldurchlass für alle Abschlussborde verfügbar  
Pasacables disponible para todos los sobres



Uso in esterno riparato  
Use in a sheltered outdoor space  
Utilisation en extérieur, en espace abrité  
Verwendung in geschütztem Außenbereich  
Uso exterior protegido



EXTENDABLE TABLE SYSTEM  
registered community design

## FINITURE/FINISHES



uso in esterno riparato  
protected outdoor use

### top tavolo / table top

0.5	legno massiccio solid wood	T01 rovere oak	T02 noce walnut	T03 iroko iroko	T04 iroko outdoor iroko outdoor	T05 rovere nero black oak
0.6	POLARIS®	L03 bianco white	L10 grigio chiaro light grey	L11 grigio scuro dark grey		
0.6	FENIX®	L08 grigio Londra London grey	L06 nero black			
0.7	HPL + legno HPL + wood	Y36 rovere oak	Y34 noce walnut	Y37 rovere affumicato smoked oak	Y40 frassino argilla clay ash	Y39 frassino nero black ash
0.7	HPL + metallo HPL + metal	C31 ottone brass	C32 ottone scuro dark brass	C35 inox inox	C36 inox scuro dark inox	
0.7	HPL + ecotouch	N01 sabbia sand	N02 basalto basalt			
0.7	HPL + cemento HPL + cement	D01 bianco calce lime white	D02 grigio Portland Portland grey	D03 nero black		
0.6	ceramica ceramic	S05 antracite anthracite	S06 nero black	S07 porfido porfido	S08 cardoso cardoso	

### telaio / structure

1.28	acciaio verniciato painted steel	C12 bianco white	C21 seta silk	C23 corda ecru	C30 ghisa cast-iron	C14 antracite anthracite
		C08 nero black	C18 verde green	C26 corten corten	C29 bronzo bronze	C37 rame copper
		C38 titanio titanium				

## DIMENSIONI/DIMENSIONS



verificare a listino geometrie e finiture  
check geometries and finishes in the price list

120/160/180/200 x 78	120/160/180/200/220/240 x 90	180/200/220/240/300 x 98	200/220/240/300 x 110
180/200 x 78	180/200/220/240 x 90	180/200/220/240/300 x 98	
180/200/220/240/300 x 98	180/200/220/240/300 x 105		
160 x 85	180 x 95	200 x 105	220 x 115
248 x 128			
120 x 120	140 x 140		120 x 120
			140 x 140
ø 128	ø 140	ø 160	
180/200/220/240/300 x 100			
tavoli allungabili extendable tables	170(260)/200(290)/230(320) x 90	170(260)/200(290)/230(320) x 98	

03/T11

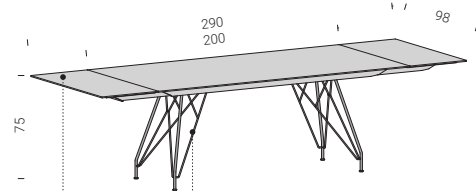

S07  
ceramic  
porfido



C08  
black



ECH4 pg. 308



EWS pg. 26



T11

- Apertura allunghe
- Opening of extensions
- Ouverture de rallonges
- Öffnung verlängerungsstücke
- Apertura de la extensión

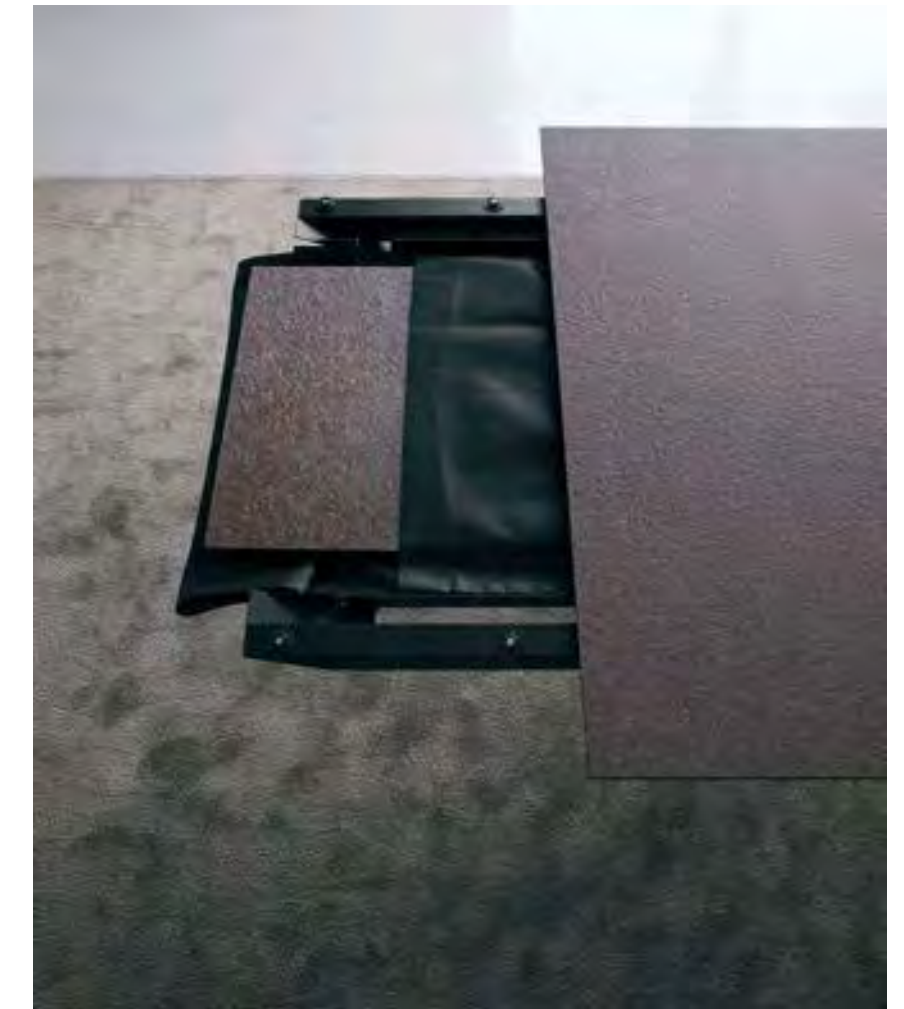

02/T11

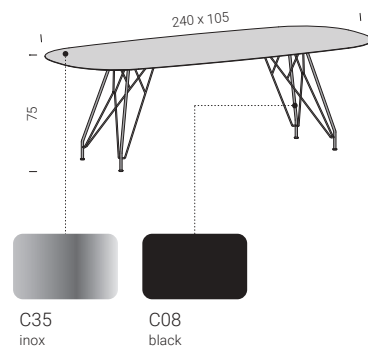

ECH4 pg. 308



CONTRAPPESO pg. 340

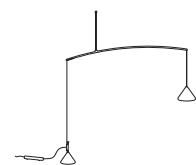



01/T11

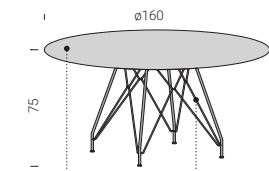

# T12



PENSARE AD UN TAVOLO ISPIRATO ALLE STRUTTURE DEI PONTI HA RESO POSSIBILE LA PRODUZIONE DI TOP DI 400 CM DI LUNGHEZZA IN UN UNICO PEZZO. IL SISTEMA A TIRANTI TENSIONABILI DEL BASAMENTO RENDE LA STRUTTURA ESTREMAMENTE RIGIDA ALLE SOLLECITAZIONI LATERALI E GARANTISCE LA PERFETTA PLANARITÀ DEL TOP.

Designing a table inspired by bridge structures has made it possible to produce a 400 cm top in a single piece. The tensioning tie rods system of the base makes the structure extremely robust and resistant to lateral stresses and guarantees perfect planarity of the top.

Penser à une table inspirée des structures de pont a permis de produire des plateaux de 400 cm de long réalisés en un unique morceau. Le système de tirants tendus du socle rend la structure extrêmement rigide face aux sollicitations latérales, avec garantie d'une planéité parfaite du plateau.

Der Gedanke an einem an die Strukturen der Brücken inspirierten Tisch hat es ermöglicht, eine 400 cm lange Tischplatte aus einem einzigen Stück zu produzieren. Das spannbare Zugstabsystem des Untergestells macht die Struktur extrem beständig gegen seitliche Beanspruchungen und gewährleistet die perfekte Ebenheit der Tischplatte.

Pensar en una mesa inspirada en las estructuras de los puentes permitió fabricar un tablero de 400 cm de largo en una sola pieza. El sistema de tensado de la base hace que la estructura sea extremadamente rígida a los esfuerzos laterales y garantiza la perfecta planitud de la parte superior.



Disponibili riduzioni a misura  
Custom reductions available  
Réductions sur mesure disponibles  
Verkürzungen auf Maß erhältlich  
Disponibles reducciones a medida



Passacavo disponibile per tutti i top  
Cable gland available for all  
Topspasse-câble disponible pour tous les plateaux  
Kabeldurchlass für alle Abschlussborde verfügbar  
Pasacables disponible para todos los sobres



Possibilità di affiancamento  
Possibility to place by side  
Possibilité d'association  
Aufstellung nebeneinander möglich  
Posibilidad de colocarse uno al lado del otro

## FINITURE/FINISHES

uso in esterno riparato  
protected outdoor use

### top tavolo / table top

0.6	POLARIS®	L03 bianco white	L10 grigio chiaro light grey	L11 grigio scuro dark grey		
0.6	FENIX®	L08 grigio Londra London grey	L06 nero black			
0.7	HPL + legno HPL + wood	Y36 rovere oak	Y34 noce walnut	Y37 rovere affumicato smoked oak	Y40 frassino argilla clay ash	Y39 frassino nero black ash
0.7	HPL + metallo HPL + metal	C31 ottone brass	C32 ottone scuro dark brass	C35 inox inox	C36 inox scuro dark inox	
0.7	HPL + ecotouch	N01 sabbia sand	N02 basalto basalt			
0.7	HPL + cemento HPL + cement	D01 bianco calce lime white	D02 grigio Portland Portland grey	D03 nero black		
0.6	ceramica ceramic	S05 antracite anthracite	S06 nero black	S07 porfido porfido	S08 cardoso cardoso	

### telaio / structure

acciaio verniciato painted steel	C12 bianco white	C21 seta silk	C23 corda ecru	C30 ghisa cast-iron	C14 antracite anthracite
	C08 nero black	C18 verde green	C26 corten corten	C29 bronzo bronze	C37 rame copper
	C38 titanio titanium				

## DIMENSIONI/DIMENSIONS

verificare a listino geometrie e finiture  
check geometries and finishes in the price list

 	200/220/240/260/280 x 90 200/220/240/260/280 x 100 220/240/260/280 x 120
 	300 x 90 300 x 100 300/360/400 x 120
 	200/220/240/260/280 x 105 220/240/260/280 x 125
 	300 x 105 300/360/400 x 125
 	440/480/520 x 100 440/480/520 x 120
 	560/600 x 100 560/600 x 120
 	440/480/520 x 105 440/480/520 x 125
 	560/600 x 105 560/600 x 125

01/T12

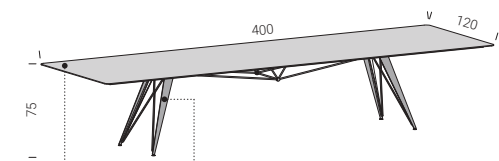

N02  
ecotouch  
basalt



C08  
black





T12

- ▶ Caratteristiche costruttive
- ▶ Construction characteristics
- ▶ Caractéristiques de construction
- ▶ Konstruktionsmerkmale
- ▶ Características constructivas

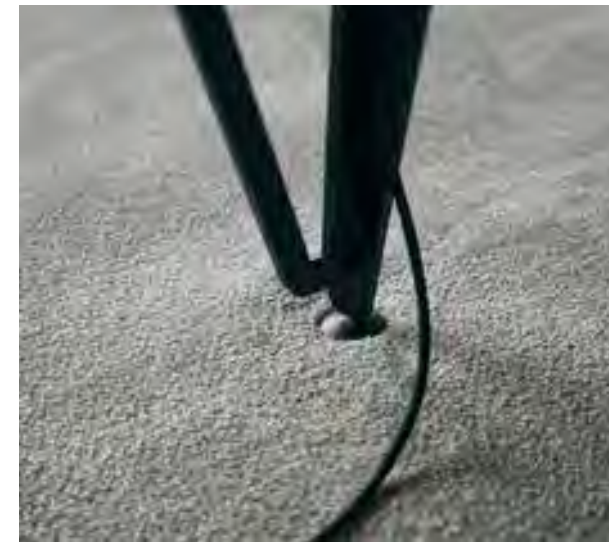

# MR. HYDE



MR. HYDE È UNA COLLEZIONE DI TAVOLI CHE NASCONDONO NELLA PARTE SOTTOSTANTE UNO O PIÙ DISCHI CON DIAMETRO 48-54 CM. I DISCHI POSSONO ESSERE ESTRATTI RUOTANDOLI, AUMENTANDO LA SUPERFICIE DISPONIBILE DEL TAVOLINO. I TOP MR.HYDE ED I DISCHI ESTRAIBILI SONO IN HPL SPESSORE 6 MM CHE NELLO SVILUPPO DEL PERIMETRO VIENE RIDOTTO TRAMITE FRESATURA AD UNO SPESSORE DI SOLI 3 MM.

Mr. Hyde is a collection of tables with one or more hidden discs of diameters between 48 and 54 cm. The discs can be extracted by turning them, thus increasing the available space on the table. The mr.hyde tops and extractable discs are in 6 mm HPL, milled around the edge to a thickness of just 3 mm.

Mr. Hyde est une collection de tables de café qui cachent dans la partie sous-jacente un ou plusieurs disques avec un diamètre de 48-54 cm. Les disques peuvent être extraits en les faisant tourner, en augmentant ainsi la superficie disponible de la table basse. Les plateaux mr.hyde et les disques extractibles sont réalisés en HPL de 6 mm d'épaisseur, qui est réduite par fraisage le long du périmètre à une épaisseur de seulement 3 mm.

Mr. Hyde ist eine Kollektion von Tables, die auf der Unterseite eine oder mehrere runde Platten mit einem Durchmesser von 48-54 cm verbergen. Die runden Platten können herausgedreht werden und vergrößern so die Ablagefläche des Tisches. Die HPL-Tischplatte und die runden Platten sind aus 6 mm starkem HPL gefertigt, der Rand ist dagegen auf eine Stärke von 3 mm.

Mr. Hyde es una colección de tables que esconden en la parte inferior uno o varios discos, con un diámetro de 48-54 cm. Los discos pueden extraerse girándolos, aumentando la superficie disponible de la mesita. Los sobres de mr.hyde y los discos extraíbles son de hpl, de 6 mm de espesor, que en el desarrollo del perímetro se reduce a través de fresado a un espesor solo de 3 mm.

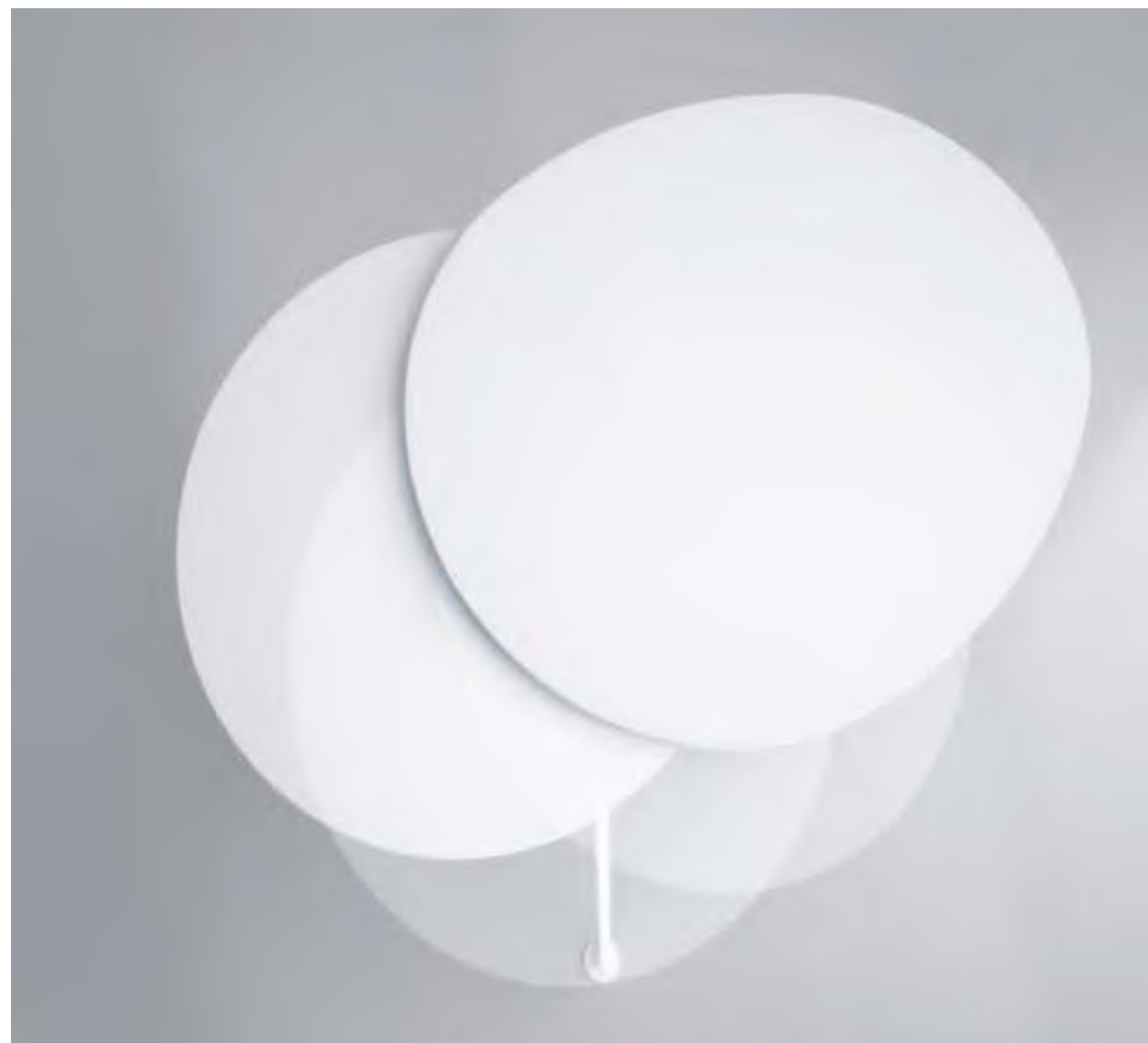

## FINITURE/FINISHES

uso in esterno riparato  
protected outdoor use

### top tavolo / table top

0.6 : 0.3 POLARIS®



0.6 : 0.3 FENIX®

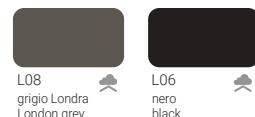

0.7 : 0.3 HPL + legno  
HPL + wood

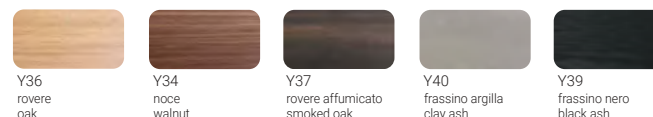

0.7 : 0.3 HPL + metallo  
HPL + metal

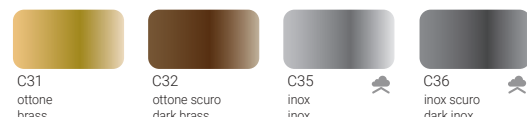

0.7 : 0.3 HPL + ecotouch



0.7 : 0.3 HPL + cemento  
HPL + cement



### telaio / structure

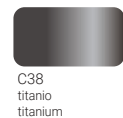
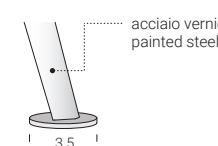

## DIMENSIONI/DIMENSIONS

verificare a listino geometrie e finiture  
check geometries and finishes in the price list

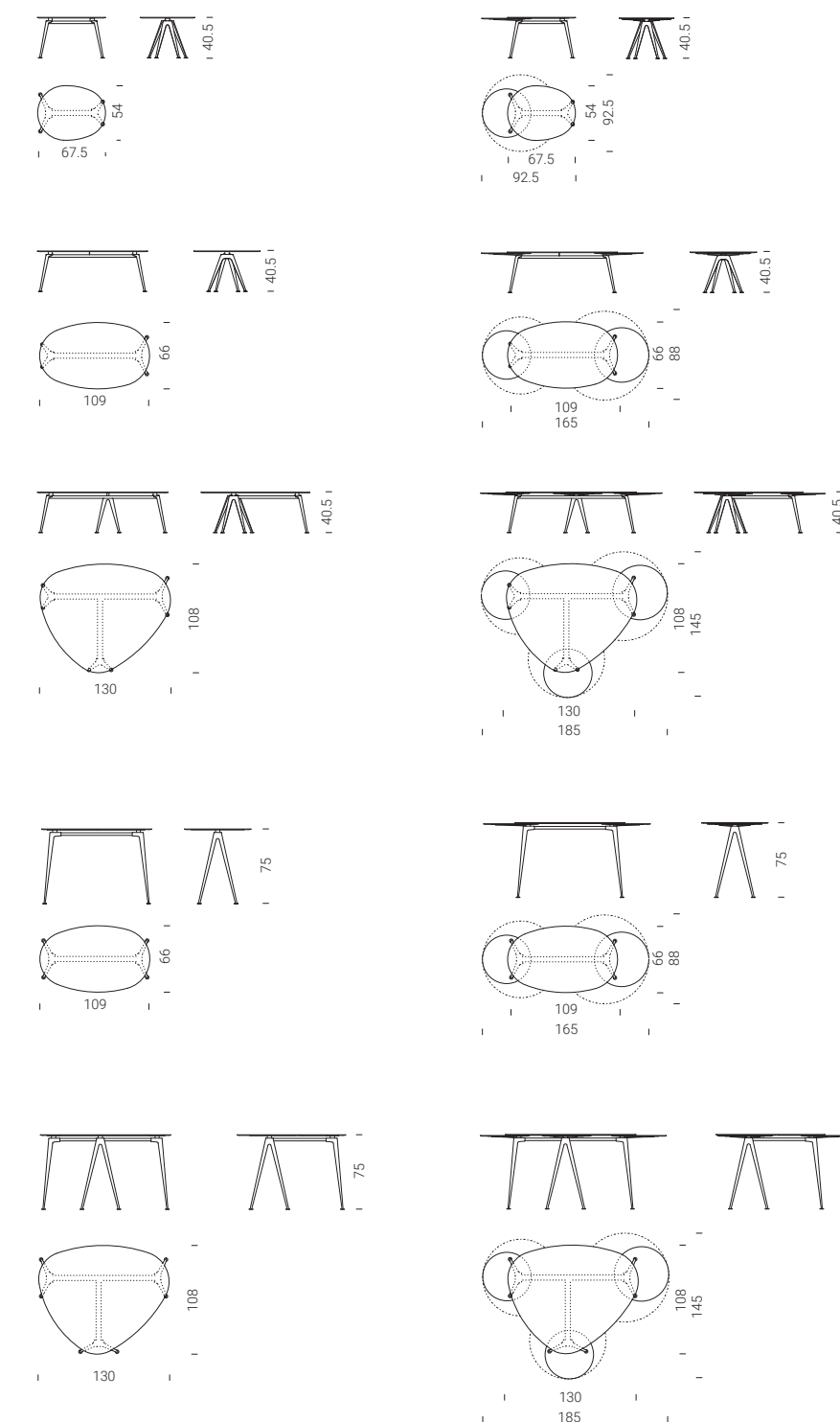

28/MR. HYDE

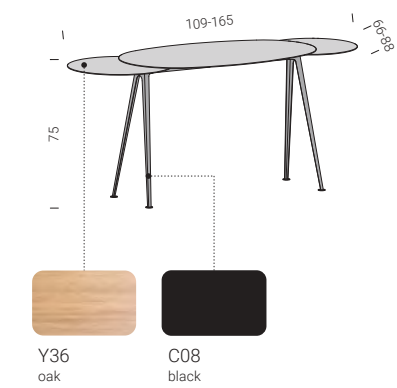

- MR.HYDE**
- Rotazione allunghe
  - Rotation of extensions
  - Rotation des rallonges
  - Rotation verlängerungsstücke
  - Rotación de extensiones



29/MR. HYDE

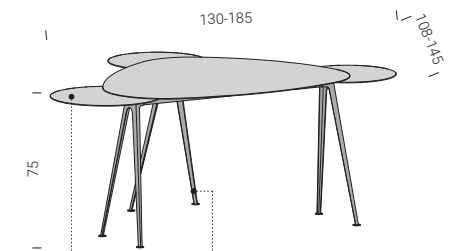

L11  
POLARIS®  
dark grey

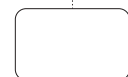

C12  
white



02/MR. HYDE

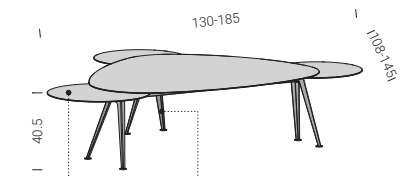

- N01 ecotouch sand
- C18 green



09/MR. HYDE

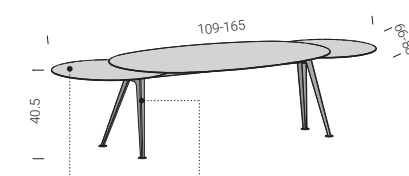

- Y36 oak
- C08 black





# DÉCO



UNA COLLEZIONE DI TAVOLINI CHE SI ISPIRA AD UNO STILE CHE HA INFLUENZATO L'ARCHITETTURA ED IL DESIGN NEGLI ANNI 30. LE NUOVE TECNOLOGIE PER LA LAVORAZIONE DEI METALLI E LE ALTE PERFORMANCE DEI MATERIALI IMPIEGATI, HANNO CONSENTITO DI REINTERPRETARE UNO STILE DALLE FORME CLASSICHE IN GEOMETRIE CONTEMPORANEE.

This is a collection of coffee tables inspired by a style that influenced both the fields of architecture and design during the 1930s. The new metalworking technologies and the high-performing materials used, have made it possible to re-interpret a style with classical forms in contemporary profiles.

Une collection de tables basses qui s'inspire d'un style qui a influencé l'architecture et le design dans les années 30. Les nouvelles technologies pour l'usinage des métaux et les performances élevées des matériaux employés ont permis de réinterpréter un style aux formes classiques en géométries contemporaines.

Eine Kollektion von Tischen, die sich am Art Déco inspiriert, einer Stilrichtung, die die Architektur und das Design der 1930er Jahre beeinflusst hat. Innovative Technologien bei der Metallbearbeitung und leistungsfähige Materialien erlauben die Neuinterpretation eines von klassischen Formen geprägten Stils, die mit zeitgenössischen Konturen überzeugt.

Una colección de mesitas inspirada en el estilo que predominó en la arquitectura y el diseño de los años 30. Las nuevas tecnologías para el procesamiento de metales y las altas prestaciones de los materiales utilizados, permitieron reinterpretar un estilo caracterizado por formas clásicas, creando geometrías contemporáneas.



## FINITURE/FINISHES



### top tavolo / table top

1.2	marmo marble	Z01 bianco Carrara white Carrara	Z02 nero Marquina black Marquina			
0.6	POLARIS®	L03 bianco white	L10 grigio chiaro light grey	L11 grigio scuro dark grey		
0.6	FENIX®	L08 grigio Londra London grey	L06 nero black			
0.7	HPL + legno HPL + wood	Y36 rovere oak	Y34 noce walnut	Y37 rovere affumicato smoked oak	Y40 frassino argilla clay ash	Y39 frassino nero black ash
0.7	HPL + metallo HPL + metal	C31 ottone brass	C32 ottone scuro dark brass	C35 inox inox	C36 inox scuro dark inox	
0.7	HPL + ecotouch	N01 sabbia sand	N02 basalto basalt			
0.7	HPL + cemento HPL + cement	D01 bianco calce lime white	D02 grigio Portland Portland grey	D03 nero black		
0.6	ceramica ceramic	S05 antracite anthracite	S06 nero black	S07 porfido porfido	S08 cardoso cardoso	

### telaio / structure

1.5	acciaio verniciato painted steel	C12 bianco white	C21 seta silk	C23 corda ecru	C30 ghisa cast-iron	C14 antracite anthracite
		C08 nero black	C18 verde green	C26 corten corten	C29 bronzo bronze	C37 rame copper
		C38 titanio titanium				

## DIMENSIONI/DIMENSIONS

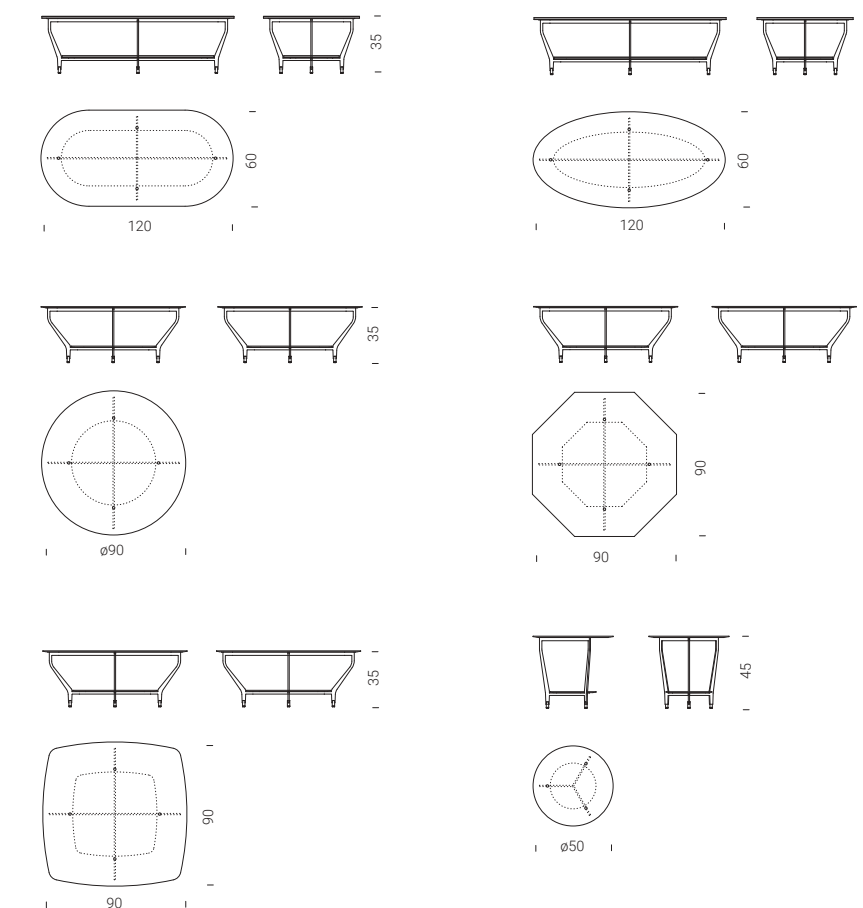

03/DÉCO

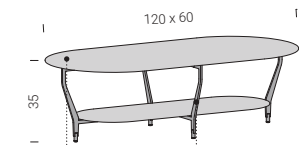

Y37  
smoked oak

C29  
bronze



ATELIER pg. 46

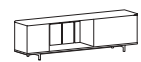

05/DÉCO

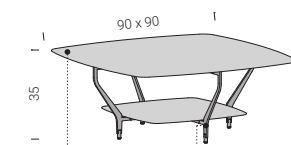

Y34  
walnut

C08  
black



ATELIER pg. 46

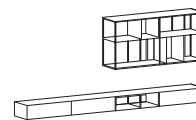

06/DÉCO

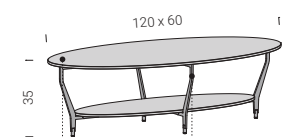

Z02  
marble  
black Marquiña



C08  
black



04/DÉCO

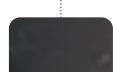
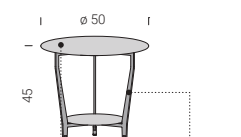

Z02  
marble  
black Marquiña



C14  
anthracite



ATELIER pg. 46

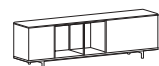

01/DÉCO

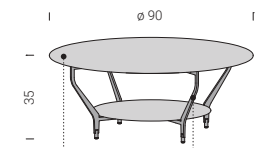

Y39  
black ash

C08  
black



ATELIER pg. 46

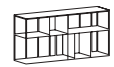

CONNECT pg. 356



02/DÉCO

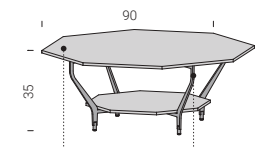

Z01  
marble  
Carrara white

C12  
white



ATELIER pg. 46



# SEATINGS

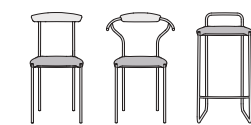

DANSKE C  
pg. 282



ECH6  
pg. 318



VIKING  
pg. 294



ECH7  
pg. 324

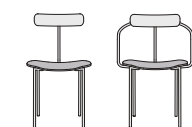

ECH3  
pg. 302

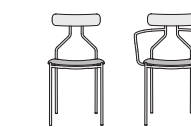

ECH8  
pg. 330



ECH4  
pg. 308



ECH9  
pg. 334



ECH5  
pg. 314

# DANSKE C

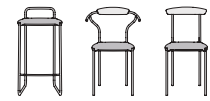

L'ACCIAIO E IL LEGNO VENGONO PLASMATI ESALTANDO LE LORO CARATTERISTICHE STRUTTURALI ED ESTETICHE. LE SINGOLE GEOMETRIE TRIDIMENSIONALI DI LEGNO E ACCIAIO SI COMPENETRANO IN UNICHE SUPERFICI. LE PARTI IN LEGNO MASSICCIO SONO PROTETTE CON VERNICE ALL'ACQUA OPACA ANTIGRAFFIO, MENTRE LE PARTI IN ACCIAIO SONO VERNICIATE A POLVERI.

Steel and wood are shaped to emphasise their structural and aesthetic characteristics. The individual, three-dimensional geometries of the wood and steel permeate in single surfaces. The solid wood parts are protected with matt, scratch-proof water-based varnish, while the steel parts are powder painted.

L'acier et le bois sont façonnés en exaltant leurs caractéristiques structurelles et esthétiques. Les différentes géométries tridimensionnelles du bois et de l'acier s'interpénètrent en surfaces uniques. Les parties en bois massif sont protégées avec du verni à l'eau opaque résistant aux rayures, alors que les parties en acier sont vernies par poudres.

Stahl und Holz sind so geformt, dass ihre strukturellen und ästhetischen Eigenschaften unterstrichen werden. Die einzelnen, dreidimensionalen Formen von Holz und Stahl durchdringen zusammen zu einzigen Oberflächen. Die Teile aus Massivholz sind mit einer Schicht aus mattem und kratzfesten Wasserlack geschützt und die Teile aus Stahl sind pulverlackiert.

El acero y la madera se modelan exaltando sus características estructurales y estéticas. Las geometrías tridimensionales individuales de la madera y el acero se compenetran en superficies únicas. Las piezas de madera maciza están protegidas con barniz mate al agua resistente a los arañazos, mientras que las piezas de acero están tratadas con barniz en polvo.



Piedini intercambiabili  
Interchangeable feet  
Pieds interchangeable  
Austauschbare Füße  
Pies intercambiables

## FINITURE/FINISHES

fondello e schienale / seat and back

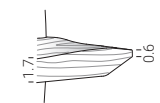

legno massiccio  
solid wood



T01  
rovere  
oak



T02  
noce  
walnut



T05  
rovere nero  
black oak

telaio / structure

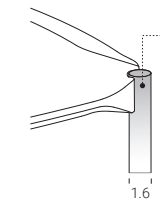

acciaio verniciato  
painted steel



C12  
bianco  
white



C21  
seta  
silk



C23  
corda  
ecru



C30  
ghisa  
cast-iron



C14  
antracite  
anthracite



C08  
nero  
black



C18  
verde  
green



C26  
corten  
corten



C29  
bronzo  
bronze



C37  
rame  
copper



C38  
titanio  
titanium

## DIMENSIONI/DIMENSIONS

C1

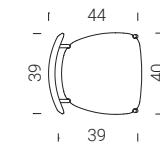
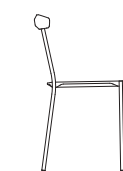
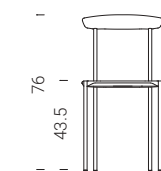

C2

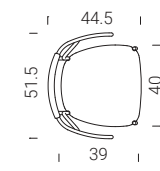
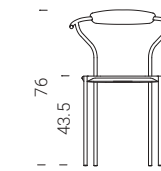

C3

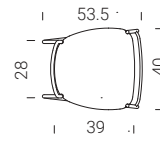
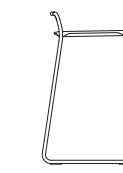
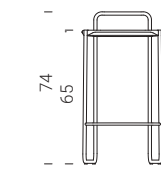

01/DANSKE C1

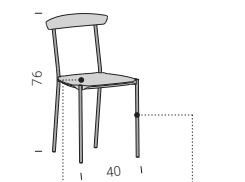

T01  
solid wood  
oak



C14  
anthracite

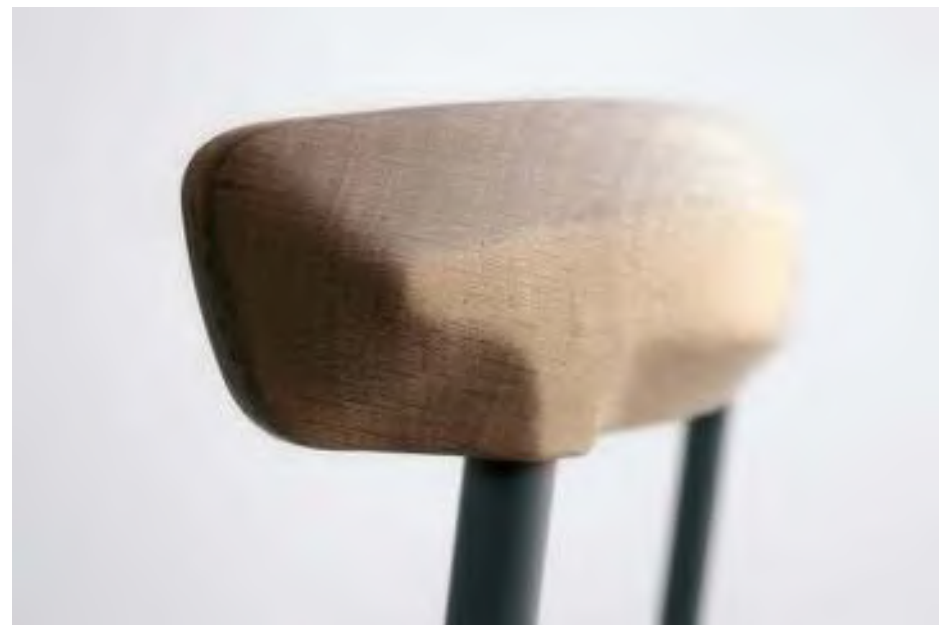

02/DANSKE C2

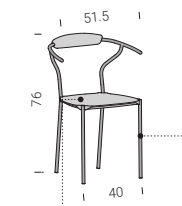

T02  
solid wood  
walnut



C08  
black



DANSKE C

- Caratteristiche costruttive
- Construction characteristics
- Caractéristiques de construction
- Konstruktionsmerkmale
- Características constructivas



05/DANSKE C2

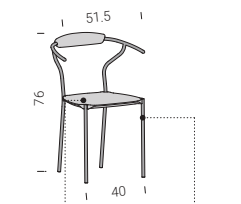

T05  
solid wood  
black oak

C08  
black



03/DANSKE C3

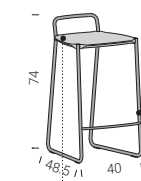

T01  
solid wood  
oak



C23  
ecru



04/DANSKE C3

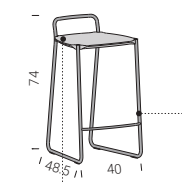

T02  
solid wood  
walnut



C08  
black



HAMMER

pg. 210

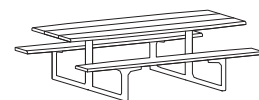

# VIKING



LA LAMA IN ACCIAIO CHE RICORDA IL PROFILO DI CHIGLIA DELLE NAVI VICHINGHE È LA SPINA DORSALE DI TUTTE LE SEDUTE CHE FANNO PARTE DELLA COLLEZIONE. SU DI ESSA SI INNESTANO IL FONDELLO LO SCHIENALE E GLI APPOGGI A TERRA. IL TELAIO È IN ACCIAIO, MENTRE I COMPONENTI DI SEDUTA E SCHIENALE SONO DISPONIBILI IN MULTISTRATO O CUOIO.

The steel blade recalling the contour of the keel of Viking ships is the backbone of all the chairs belonging to this collection. The chair seat, the backrest and the chair legs are inserted onto this. The chair frame is made of steel, while the seat and backrest are available in either plywood or leather.

La lame en acier qui rappelle le profil de la quille des navires vikings est l'épine dorsale de toutes les assises qui font partie de la collection. C'est sur elle que s'enclenchent le fond, le dossier et les appuis au sol. Le châssis est en acier alors que les composants de l'assise et du dossier sont disponibles en multicouche ou en cuir.

Ein Stahlprofil, das an den Rumpf der Wikingerschiffe erinnert, stellt das Rückgrat aller Stühle dieser Kollektion dar, an dem die Sitzfläche, die Rückenlehne und die Bodenstützen befestigt sind. Der Rahmen ist aus Stahl gefertigt, während die Sitzflächen und die Lehnen in Sperrholz oder Leder erhältlich sind.

La cuchilla de acero que recuerda el perfil de la quilla de los barcos vikingos, es la espina dorsal de todos los asientos que forman parte de la colección. Sobre ella, se ensamblan el fondo, el respaldo y los apoyos en el suelo. El bastidor es de acero, mientras que los componentes del asiento y el respaldo, están disponibles en madera estratificada o cuero.



Schienale adattivo  
Adjustable backrest  
Dossier adaptatif  
Adaptive Rückenlehne  
Respaldo adaptable



ADAPTIVE  
CHAIR BACKREST  
registered community  
design



Sfoderabile  
Removable upholstery  
Déhoussable  
Abnehmbares Polsterzeug  
Cubierta desmontable



Piedini intercambiabili  
Interchangeable feet  
Pieds interchangeables  
Austauschbare Füße  
Pies intercambiables

## FINITURE/FINISHES

### fondello e schienale / seat and back

	essenze woods		Y36 rovere oak		Y34 noce walnut		Y37 rovere affumicato smoked oak		Y40 frassino argilla clay ash		Y39 frassino nero black ash		
	cuoio cow-hide		F01 tabacco tobacco		F02 nero black								
	100% poliestere/polyester peso/weight: 400 gr/mq BSI : 50.000 cicli/cycles		JA01 perla pearl		JA02 avorio ivory		JA03 fango mud		JA04 salvia sage		JA05 oliva olive		JA06 cipria powder pink
	50% cotone/cotton 40% poliestere/polyester 10% poliacrilico/polyacrylic peso/weight: 430 gr/mq BSI : 40.000 cicli/cycles		JB01 natur natur		JB02 ecru ecru		JB03 grigio grey		JB04 cenere ash		JB05 platino platinum		JB06 antracite anthracite
	60% lino/linen 40% viscosa/viscose peso/weight: 550 gr/mq BSI : 20.000 cicli/cycles		JC01 fumo smoke		JC02 cenere ash		JC03 sacco sack		JC04 terra land		JC05 verde green		JC06 rosa pink

### telaio / structure

	acciaio verniciato painted steel		C12 bianco white		C21 seta silk		C23 corda ecru		C30 ghisa cast-iron		C14 antracite anthracite		C08 nero black
			C18 verde green		C26 corten corten		C29 bronzo bronze		C37 rame copper		C38 titanio titanium		

## DIMENSIONI/DIMENSIONS

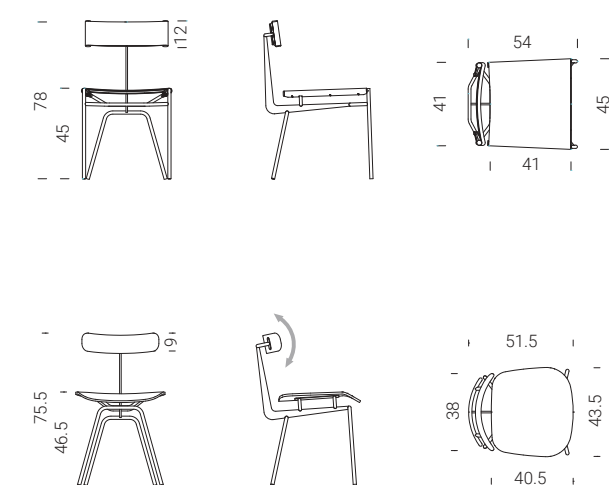

verificare a listino disponibilità, composizione e consigli di lavaggio per i tessuti.  
check availability, composition and washing recommendations for fabrics in the price list.

01/VIKING K

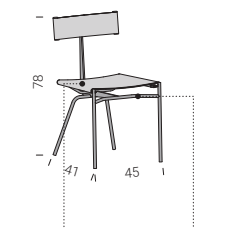

- F02 cow-hide black
- C08 black



- VIKING K
- ▶ Caratteristiche costruttive
  - ▶ Construction characteristics
  - ▶ Caractéristiques de construction
  - ▶ Konstruktionsmerkmale
  - ▶ Características constructivas

ATELIER pg. 46

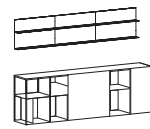

T8 pg. 224

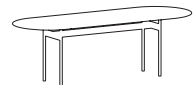

06/VIKING K

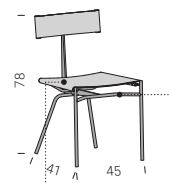

F01  
cow-hide  
tobacco



C08  
black



T9

pg. 234



07/VIKING W

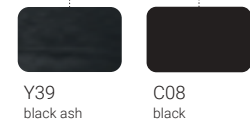
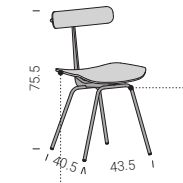

Y39  
black ash

C08  
black



05/VIKING W

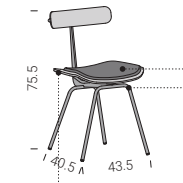

Y34  
walnut

C08  
black

F01  
cow-hide  
tobacco



VIKING W

- Caratteristiche costruttive
- Construction characteristics
- Caractéristiques de construction
- Konstruktionsmerkmale
- Características constructivas

T9 pg. 234



URANO pg. 388

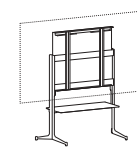

# ECH3

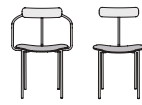

CARATTERIZZATA DA UN'AMPIA E COMODA SEDUTA OVALE E DAL MECCANISMO DI SCHIENALE ADATTIVO, LA COLLEZIONE RAPPRESENTA LA SINTESI TRA RIGORE GEOMETRICO E RICERCA DI MASSIMO CONFORT. PER FONDELLO E SCHIENALE SONO DISPONIBILI RIVESTIMENTI IN TESSUTO SFODERABILE CHE NE CONSENTONO IL LAVAGGIO O IL RICAMBIO.

Characterized by a large and comfortable oval seat and backrest adjustment mechanism, the collection represents the synthesis between geometric rigour and the search for maximum comfort. For the seating and backrest there is removable fabric upholstery to allow it to be cleaned or changed.

Caractérisée par une assise ovale large et confortable et un mécanisme de dossier adaptatif, la collection est une synthèse entre la rigueur géométrique et la recherche du meilleur confort. Des housses en tissu amovibles sont disponibles pour le fond et le dossier, afin de permettre leur lavage et leur remplacement.

Gekennzeichnet durch eine breite und bequeme ovale Sitzfläche und durch den adaptiven Rückenlehnen-Mechanismus stellt die Kollektion die Synthese zwischen der geometrischen Strenge und die Suche nach dem höchsten Komfort dar. Für Sitzfläche und Rückenlehne sind Überzüge mit abnehmbaren Polsterzeug verfügbar, die deren Waschen und Austausch ermöglichen.

Caracterizada por un amplio y cómodo asiento ovalado y un mecanismo de respaldo adaptable, la colección representa la síntesis del rigor geométrico y la búsqueda del máximo confort. Hay fundas de tela extraíbles para el asiento y el respaldo, que permiten lavarlas o sustituirlas.



Schienale adattivo  
Adjustable backrest  
Dossier adaptatif  
Adaptive Rückenlehne  
Respaldo adaptable



ADAPTIVE  
CHAIR BACKREST  
registered community  
design



Sfoderabile  
Removable upholstery  
Déhoussable  
Abnehmbares Polsterzeug  
Cubierta desmontable



Piedini intercambiabili  
Interchangeable feet  
Pieds interchangeables  
Austauschbare Füße  
Pies intercambiables

## FINITURE/FINISHES

### fondello e schienale / seat and back

	essenze woods					
		Y36 rovere oak	Y34 noce walnut	Y37 rovere affumicato smoked oak	Y40 frassino argilla clay ash	Y39 frassino nero black ash
	cuoio cow-hide					
		F01 tabacco tobacco	F02 nero black			
	100% poliestere/polyester					
	peso/weight: 400 gr/mq BSI : 50.000 cicli/cycles	JA01 perla pearl	JA02 avorio ivory	JA03 fango mud	JA04 salvia sage	JA05 oliva olive
						JA06 cipria powder pink
	50% cotone/cotton 40% poliestere/polyester 10% poliacrilico/polyacrylic					
	peso/weight: 430 gr/mq BSI : 40.000 cicli/cycles	JB01 natur natur	JB02 ecru ecru	JB03 grigio grey	JB04 cenere ash	JB05 platino platinum
						JB06 antracite anthracite
	60% lino/linen 40% viscosa/viscose					
	peso/weight: 550 gr/mq BSI : 20.000 cicli/cycles	JC01 fumo smoke	JC02 cenere ash	JC03 sacco sack	JC04 terra land	JC05 verde green
						JC06 rosa pink

### telaio / structure

	acciaio verniciato painted steel						
		C12 bianco white	C21 seta silk	C23 corda ecru	C30 ghisa cast-iron	C14 antracite anthracite	C08 nero black
		C18 verde green	C26 corten corten	C29 bronzo bronze	C37 rame copper	C38 titanio titanium	

## DIMENSIONI/DIMENSIONS

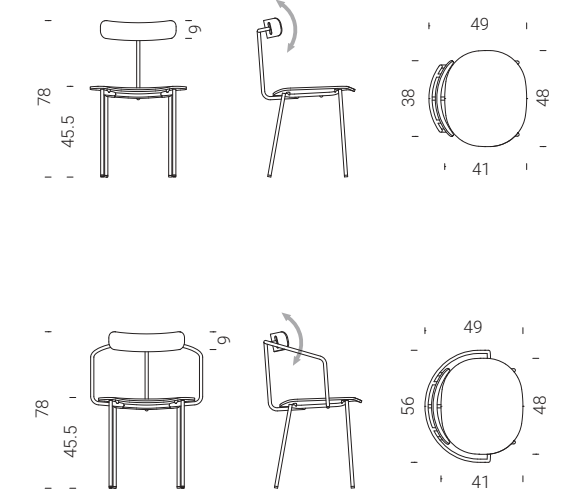

verificare a listino disponibilità, composizione e consigli di lavaggio per i tessuti.  
check availability, composition and washing recommendations for fabrics in the price list.



01/ECH3

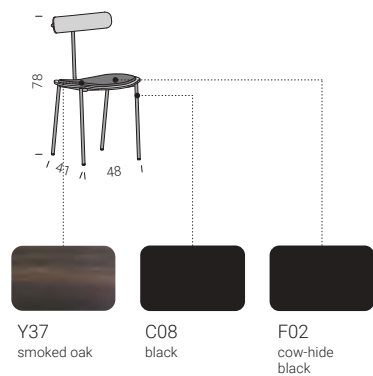

02/ECH3

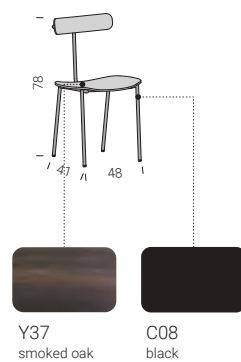

ECH3

- Caratteristiche costruttive
- Construction characteristics
- Caractéristiques de construction
- Konstruktionsmerkmale
- Características constructivas

MONOLITH pg. 74

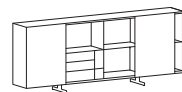

ST35 pg. 186

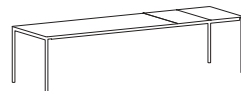

T12 pg. 258



04/ECH3

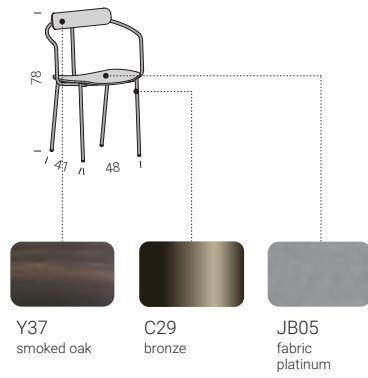

03/ECH3

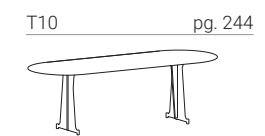

# ECH4



IL DISEGNO LEGGERO DERIVA DAI PROFILI IN ACCIAIO A SEZIONE RIDOTTA CHE COSTITUISCONO IL TELAIO: 6/12 MM PER LE QUATTRO RAZZE CONTROVENTATE DA TIRANTI CHE NE IRRIGIDISCONO LA STRUTTURA. GLI SCHIENALI ADATTIVI E I FONDELLI IN TESSUTO SFODERABILE SONO DISPONIBILI NELLA VERSIONE CON O SENZA BRACCIOLI.

The light design is the result of the steel profiles with reduced cross-section that form the frame: 6/12 mm for the four spokes braced by tie-rods that stiffen the structure. The adjustable backrests and removable fabric upholstery seats of the chairs are available in versions with or without arms.

La légèreté du design passe par les profilés en acier à section réduite qui composent le cadre : 6/12 mm pour les quatre rayons renforcés par les tirants qui rigidifient la structure. Les dossiers et les fonds adaptatifs en tissu amovible sont disponibles dans la version avec ou sans accoudoirs.

Das leichte Design kommt aus den Stahlprofilen mit reduziertem Schnitt, die das Gestell bilden: 6/12 mm für die vier verspannten Speichen, die die Struktur versteifen. Die adaptiven Rückenlehnen und die Sitzflächen mit abnehmbarem Polsterzeug sind in der Version mit oder ohne Armlehnen verfügbar.

La ligereza se debe a los perfiles de acero de sección reducida que componen el bastidor: 6/12 mm para los cuatro radios arriostrados por tirantes que endurecen la estructura. Los respaldos adaptables y las fundas de tela extraíbles están disponibles con o sin reposabrazos.



Schienale adattivo  
Adjustable backrest  
Dossier adaptatif  
Adaptive Rückenlehne  
Respaldo adaptable



ADAPTIVE  
CHAIR BACKREST  
registered community  
design



Sfoderabile  
Removable upholstery  
Déhoussable  
Abnehmbares Polsterzeug  
Cubierta desmontable



Piedini intercambiabili  
Interchangeable feet  
Pieds interchangeables  
Austauschbare Füße  
Pies intercambiables

## FINITURE/FINISHES

### fondello e schienale / seat and back

	essenze woods					
	cuoio cow-hide					
	100% poliestere/polyester peso/weight: 400 gr/mq BSI: 50.000 cicli/cycles					
	50% cotone/cotton 40% poliestere/polyester 10% poliacrilico/polyacrylic peso/weight: 430 gr/mq BSI: 40.000 cicli/cycles					
	60% lino/linen 40% viscosa/viscose peso/weight: 550 gr/mq BSI: 20.000 cicli/cycles					

### telaio / structure

	acciaio verniciato painted steel						

## DIMENSIONI/DIMENSIONS

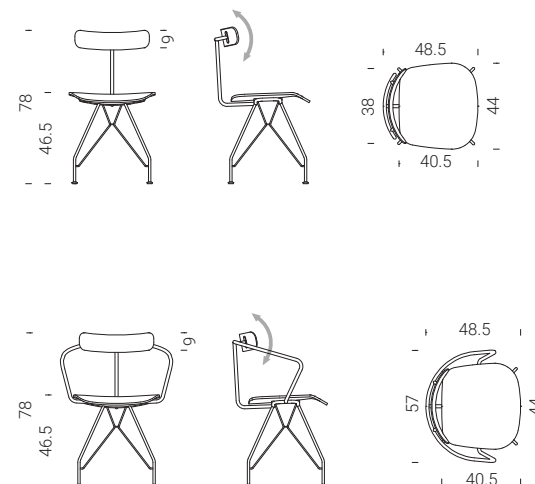

verificare a listino disponibilità, composizione e consigli di lavaggio per i tessuti.  
check availability, composition and washing recommendations for fabrics in the price list.

02/ECH4



Y37 smoked oak  
C29 bronze  
JB01 fabric natur  
Y39 black ash



T11 pg. 250

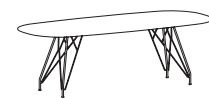

CONTRAPPESO pg. 340

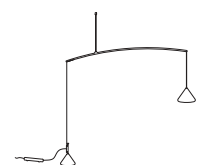

ECH4

- ▶ Caratteristiche costruttive
- ▶ Construction characteristics
- ▶ Caractéristiques de construction
- ▶ Konstruktionsmerkmale
- ▶ Características constructivas

01/ECH4

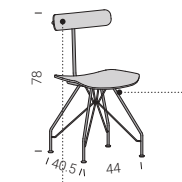

Y34  
walnut



C08  
black



ATELIER pg. 46



ST35 pg. 186



03/ECH4

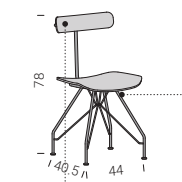

Y39  
black ash



C08  
black

T11 pg. 250

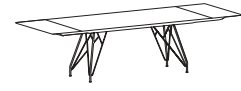

EWS pg. 26

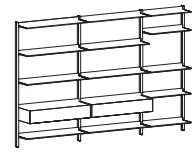

# ECH5

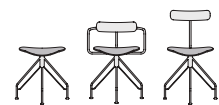

VARIANTE GIREVOLE DI ECH4, SI CARATTERIZZA PER LA STESSA STRUTTURA IN PROFILI D'ACCIAIO A SEZIONE RIDOTTA, NELLA QUALE LE QUATTRO RAZZE CONVERGONO NEL CONNETTORE GIREVOLE. LE SEDUTE CON BRACCIOLI HANNO UN'ALTEZZA CHE PERMETTE LA COMPLETA ROTAZIONE AL DI SOTTO DEL TOP TAVOLO. GLI SCHIENALI ADATTIVI SONO DISPONIBILI PER LE SEDIE CON O SENZA BRACCIOLI.

The revolving version of ECH4 has the same structure with small cross-section steel profiles, in which the four spokes converge in the revolving connector. The chairs with arms have a height that allows their full rotation under the table top. The adjustable backrests are available for the chairs with or without arms.

Variante pivotante du modèle ECH4, elle se caractérise par la même structure avec profilés en acier à section réduite, dans laquelle les quatre rayons convergent vers le connecteur pivotant. Les sièges avec accoudoirs ont une hauteur qui permet une rotation complète sous le plateau de la table. Des dossiers adaptatifs sont disponibles pour les chaises avec ou sans accoudoirs.

Drehbare Variante von ECH4, sie ist durch dieselbe Struktur aus Stahlprofilen mit reduziertem Schnitt gekennzeichnet, bei der die vier Speichen am drehbaren Verbindungselement zusammenlaufen. Die Sitzmöbel mit Armlehnen haben eine Höhe, die die komplette Drehung unterhalb der Tischplatte ermöglichen. Die adaptiven Rückenlehnen sind für die Stühle mit oder ohne Armlehnen verfügbar.

La variante giratoria de la ECH4, se caracteriza por la misma estructura de perfil de acero de sección reducida, en la que los cuatro radios convergen en el conector giratorio. Los asientos con reposabrazos tienen una altura que permite una rotación completa por debajo del tablero. Los respaldos adaptables están disponibles para sillas con o sin reposabrazos.



Schienale adattivo  
Adjustable backrest  
Dossier adaptatif  
Adaptive Rückenlehne  
Respaldo adaptable



ADAPTIVE  
CHAIR BACKREST  
registered community  
design



Sfoderabile  
Removable upholstery  
Déhoussable  
Abnehmbares Polsterzeug  
Cubierta desmontable



Piedini intercambiabili  
Interchangeable feet  
Pieds interchangeables  
Austauschbare Füße  
Pies intercambiables

## FINITURE/FINISHES

### fondello e schienale / seat and back

	essenze woods		Y36 rovere oak		Y34 noce walnut		Y37 rovere affumicato smoked oak		Y40 frassino argilla clay ash		Y39 frassino nero black ash		
	cuoio cow-hide		F01 tabacco tobacco		F02 nero black								
	100% poliestere/polyester peso/weight: 400 gr/mq BSI : 50.000 cicli/cycles		JA01 perla pearl		JA02 avorio ivory		JA03 fango mud		JA04 salvia sage		JA05 oliva olive		JA06 cipria powder pink
	50% cotone/cotton 40% poliestere/polyester 10% poliacrilico/polyacrylic peso/weight: 430 gr/mq BSI : 40.000 cicli/cycles		JB01 natur natur		JB02 ecru ecru		JB03 grigio grey		JB04 cenere ash		JB05 platino platinum		JB06 antracite anthracite
	60% lino/linen 40% viscosa/viscose peso/weight: 550 gr/mq BSI : 20.000 cicli/cycles		JC01 fumo smoke		JC02 cenere ash		JC03 sacco sack		JC04 terra land		JC05 verde green		JC06 rosa pink

### telaio / structure

	acciaio verniciato painted steel		C12 bianco white		C21 seta silk		C23 corda ecru		C30 ghisa cast-iron		C14 antracite anthracite		C08 nero black
			C18 verde green		C26 corten corten		C29 bronzo bronze		C37 rame copper		C38 titanio titanium		

## DIMENSIONI/DIMENSIONS

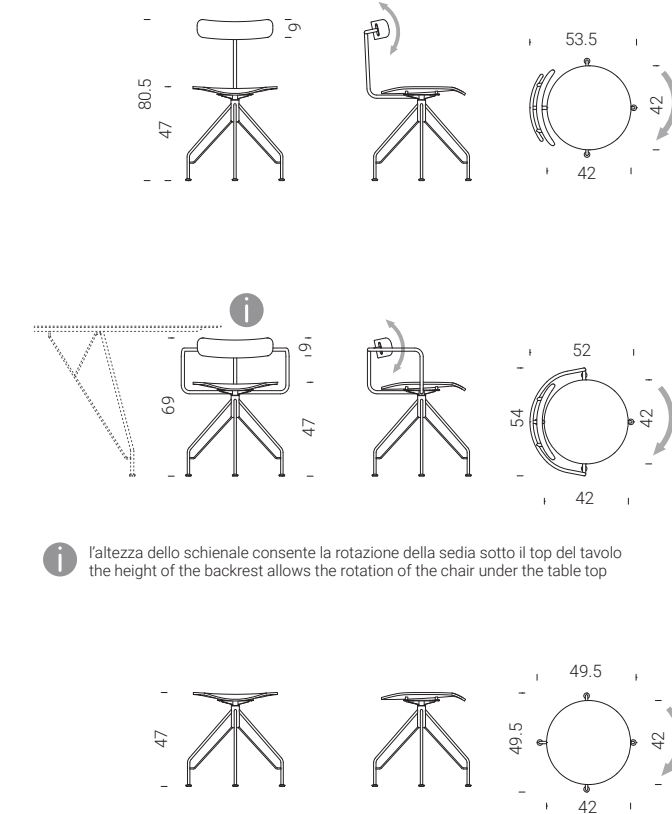

**i** l'altezza dello schienale consente la rotazione della sedia sotto il top del tavolo  
the height of the backrest allows the rotation of the chair under the table top

**A** verificare a listino disponibilità, composizione e consigli di lavaggio per i tessuti.  
check availability, composition and washing recommendations for fabrics in the price list.

01/ECH5

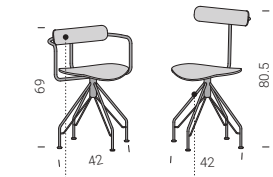

JC03  
fabric  
sack

C08  
black



02/ECH5

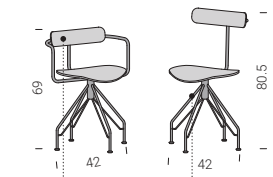

Y39  
black ash

C08  
black



ECH5

- Caratteristiche costruttive
- Construction characteristics
- Caractéristiques de construction
- Konstruktionsmerkmale
- Características constructivas

ATELIER pg. 46

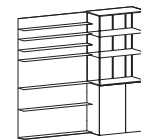

T7 pg. 218



# ECH6



IL DESIGN DELLA COLLEZIONE È DEFINITO DA QUATTRO RAZZE RASTREIMATE CHE CONVERGONO NEL CONNETTORE CENTRALE GIREVOLE. NE FANNO PARTE SGABELLI IN DUE ALTEZZE E SEDIE CON O SENZA BRACCIOLI CON SCHIENALE ADATTIVO. LE SEDUTE CON BRACCIOLI HANNO UN'ALTEZZA CHE PERMETTE LA COMPLETA ROTAZIONE AL DI SOTTO DEL TOP TAVOLO.

The design of the collection is defined by four tapered spokes that converge in the central revolving connector. The collection includes stools in two different heights and chairs with or without arms and adjustable backrest. The chairs with arms have a height that allows their full rotation under the table top.

Le design de la collection est défini par quatre rayons coniques qui convergent vers le connecteur pivotant central. La collection comprend des tabourets en deux hauteurs et des chaises, avec ou sans accoudoirs, à dossiers adaptatifs. Les sièges avec accoudoirs ont une hauteur qui permet une rotation complète sous le plateau de la table.

Das Design der Kollektion ist durch vier verjüngte Speichen bestimmt, die am zentralen drehbaren Verbindungselement zusammenlaufen. Dazu gehören Hocker in zwei Höhen und Stühle mit oder ohne Armlehnen mit adaptiver Rückenlehne. Die Sitzmöbel mit Armlehnen haben eine Höhe, die die komplette Drehung unterhalb der Tischplatte ermöglichen.

El diseño de la colección está definido por cuatro radios cónicos que convergen en el conector central giratorio. Incluye taburetes en dos alturas y sillas con o sin reposabrazos con respaldos adaptables. Las sillas con reposabrazos tienen una altura que les permite girar completamente bajo el tablero de la mesa.



Schienale adattivo  
Adjustable backrest  
Dossier adaptatif  
Adaptive Rückenlehne  
Respaldo adaptable



ADAPTIVE  
CHAIR BACKREST  
registered community  
design



Sfoderabile  
Removable upholstery  
Déhoussable  
Abnehmbares Polsterzeug  
Cubierta desmontable



Piedini intercambiabili  
Interchangeable feet  
Pieds interchangeables  
Austauschbare Füße  
Pies intercambiables

## FINITURE/FINISHES

### fondello e schienale / seat and back

	essenze woods					
		Y36 rovere oak	Y34 noce walnut	Y37 rovere affumicato smoked oak	Y40 frassino argilla clay ash	Y39 frassino nero black ash
	cuoio cow-hide					
		F01 tabacco tobacco	F02 nero black			
	100% poliestere/polyester peso/weight: 400 gr/mq BSI : 50.000 cicli/cycles					
		JA01 perla pearl	JA02 avorio ivory	JA03 fango mud	JA04 salvia sage	JA05 oliva olive
	50% cotone/cotton 40% poliestere/polyester 10% poliacrilico/polyacrylic peso/weight: 430 gr/mq BSI : 40.000 cicli/cycles					
		JB01 natur natur	JB02 ecru ecru	JB03 grigio grey	JB04 cenere ash	JB05 platino platinum
	60% lino/linen 40% viscosa/viscose peso/weight: 550 gr/mq BSI : 20.000 cicli/cycles					
		JC01 fumo smoke	JC02 cenere ash	JC03 sacco sack	JC04 terra land	JC05 verde green

### telaio / structure

	acciaio verniciato painted steel						
		C12 bianco white	C21 seta silk	C23 corda ecru	C30 ghisa cast-iron	C14 antracite anthracite	C08 nero black
		C18 verde green	C26 corten corten	C29 bronzo bronze	C37 rame copper	C38 titanio titanium	

## DIMENSIONI/DIMENSIONS

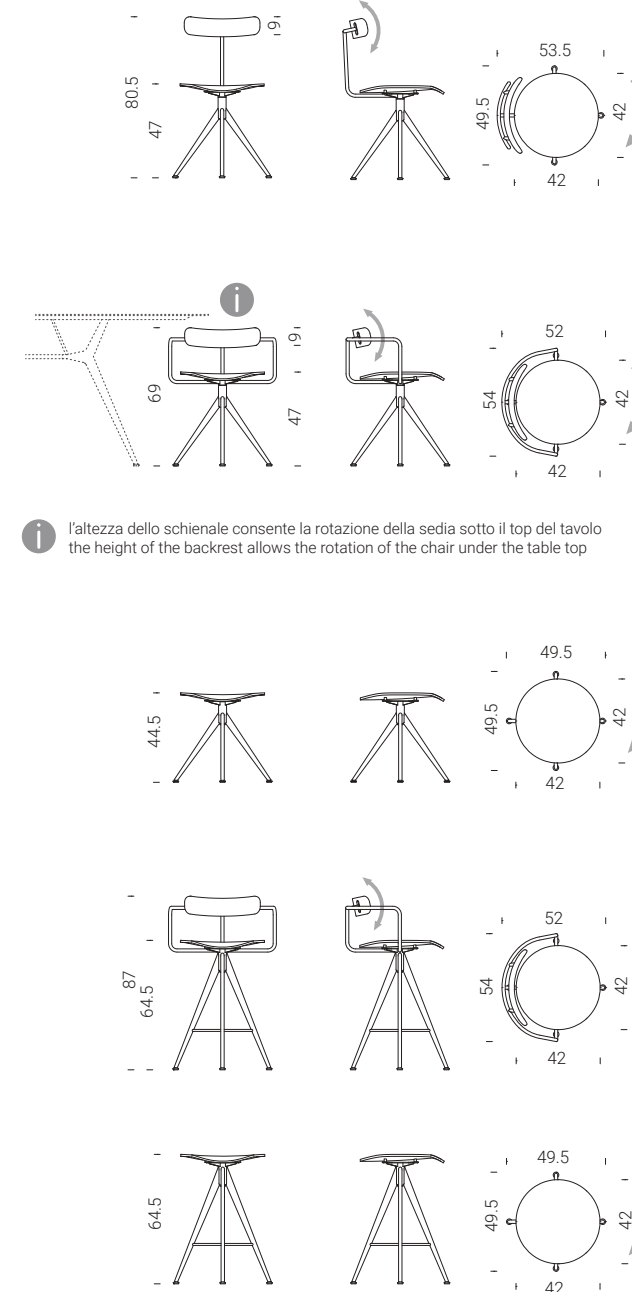

**i** l'altezza dello schienale consente la rotazione della sedia sotto il top del tavolo  
the height of the backrest allows the rotation of the chair under the table top

**!** verificare la listino disponibilità, composizione e consigli di lavaggio per i tessuti.  
check availability, composition and washing recommendations for fabrics in the price list.



01/ECH6

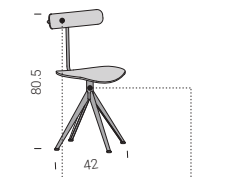

JB05  
fabric  
platinum

C08  
black

T9 pg. 234

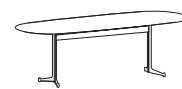

CONTRAPPESO pg. 340

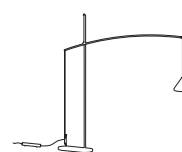

02/ECH6

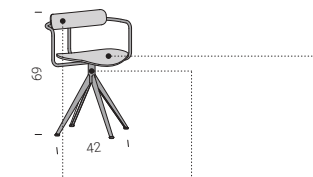

Y37  
smoked oak

C08  
black

JC03  
fabric  
sack



ECH6

- ▶ Caratteristiche costruttive
- ▶ Construction characteristics
- ▶ Caractéristiques de construction
- ▶ Konstruktionsmerkmale
- ▶ Características constructivas

ATELIER pg. 46

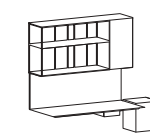

03/ECH6

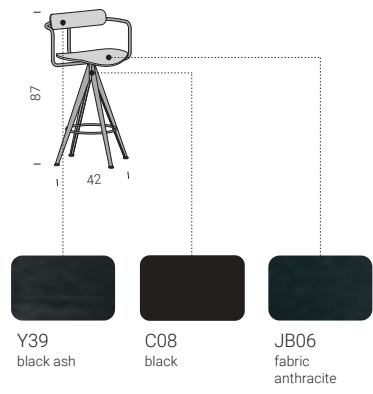

04/ECH6

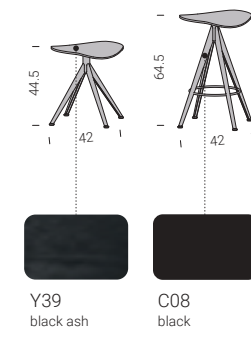

CONTRAPPESO pg. 340

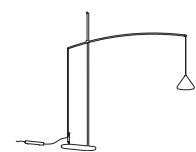

# ECH7



NEL BASAMENTO DAL RIDOTTO INGOMBRO, LE RAZZE, COSTITUITE DA PROFILI DI 16 MM, SI CURVANO E SI RACCORDANO CON UN ELEMENTO A CROCIERA CREANDO UN UNICO CORPO SALDATO. GLI SCHIENALI ADATTIVI E GLI AMPI FONDELLI OVALI IN TESSUTO SFODERABILE SONO DISPONIBILI NELLA VERSIONE CON O SENZA BRACCIOLI.

On the small sized base, the spokes, with 16 mm profiles, bend and connect with a cross element, creating a single welded body. The adjustable backrests and large removable upholstery oval chair seats are available with or without arms.

Dans la base compacte, les rayons, constitués de profilés de 16 mm, se plient et se connectent à un élément transversal pour créer un unique corps soudé. Les dossiers adaptatifs et les vastes fonds ovales en tissu amovible sont disponibles dans la version avec ou sans accoudoirs.

Im kleinen Untergestell biegen sich die aus 16 mm Profilen bestehenden Speichen und verbinden sich mit einem kreuzförmigen Element und bilden so einen einzigen Körper. Die adaptiven Rückenlehnen und die großen ovalen Sitzflächen mit abnehmbarem Polsterzeug sind in der Version mit oder ohne Armlehnen verfügbar.

En la base que ahorra espacio, los radios fabricados con perfiles de 16 mm se curvan y se unen con un elemento en forma de cruz para crear un único cuerpo soldado. Los respaldos adaptables y los grandes respaldos ovalados con fundas de tela extraíbles están disponibles con o sin reposabrazos.



Schienale adattivo  
Adjustable backrest  
Dossier adaptatif  
Adaptive Rückenlehne  
Respaldo adaptable



ADAPTIVE  
CHAIR BACKREST  
registered community  
design



Sfoderabile  
Removable upholstery  
Déhoussable  
Abnehmbares Polsterzeug  
Cubierta desmontable



Piedini intercambiabili  
Interchangeable feet  
Pieds interchangeables  
Austauschbare Füße  
Pies intercambiables

## FINITURE/FINISHES

### fondello e schienale / seat and back

	essenze woods					
		Y36 rovere oak	Y34 noce walnut	Y37 rovere affumicato smoked oak	Y40 frassino argilla clay ash	Y39 frassino nero black ash
	cuoio cow-hide					
		F01 tabacco tobacco	F02 nero black			
	100% poliestere/polyester					
		JA01 perla pearl	JA02 avorio ivory	JA03 fango mud	JA04 salvia sage	JA05 oliva olive
	50% cotone/cotton 40% poliestere/polyester 10% poliacrilico/polyacrylic					
		JB01 natur natur	JB02 ecru ecru	JB03 grigio grey	JB04 cenere ash	JB05 platino platinum
	60% lino/linen 40% viscosa/viscose					
		JC01 fumo smoke	JC02 cenere ash	JC03 sacco sack	JC04 terra land	JC05 verde green
		JC06 rosa pink				

### telaio / structure

	acciaio verniciato painted steel						
		C12 bianco white	C21 seta silk	C23 corda ecru	C30 ghisa cast-iron	C14 antracite anthracite	C08 nero black
		C18 verde green	C26 corten corten	C29 bronzo bronze	C37 rame copper	C38 titanio titanium	

## DIMENSIONI/DIMENSIONS

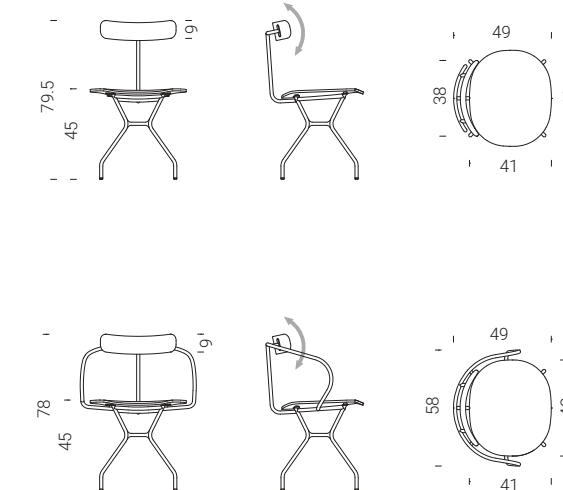

verificare a listino disponibilità, composizione e consigli di lavaggio per i tessuti.  
check availability, composition and washing recommendations for fabrics in the price list.

04/ECH7

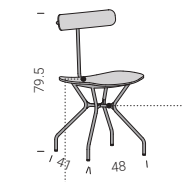

JC03  
fabric  
sack

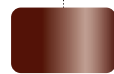

C37  
copper



ST35 pg. 186



02/ECH7

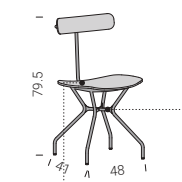

F02  
cow-hide  
black



C08  
black



ECH7

- ▶ Caratteristiche costruttive
- ▶ Construction characteristics
- ▶ Caractéristiques de construction
- ▶ Konstruktionsmerkmale
- ▶ Características constructivas

T10 pg. 244



01/ECH7

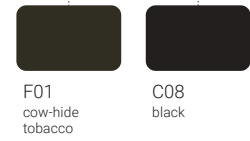
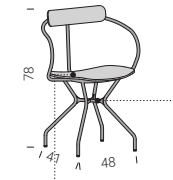

F01  
cow-hide  
tobacco

C08  
black



03/ECH7

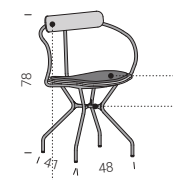

Y39  
black ash

C08  
black

JC04  
fabric  
land

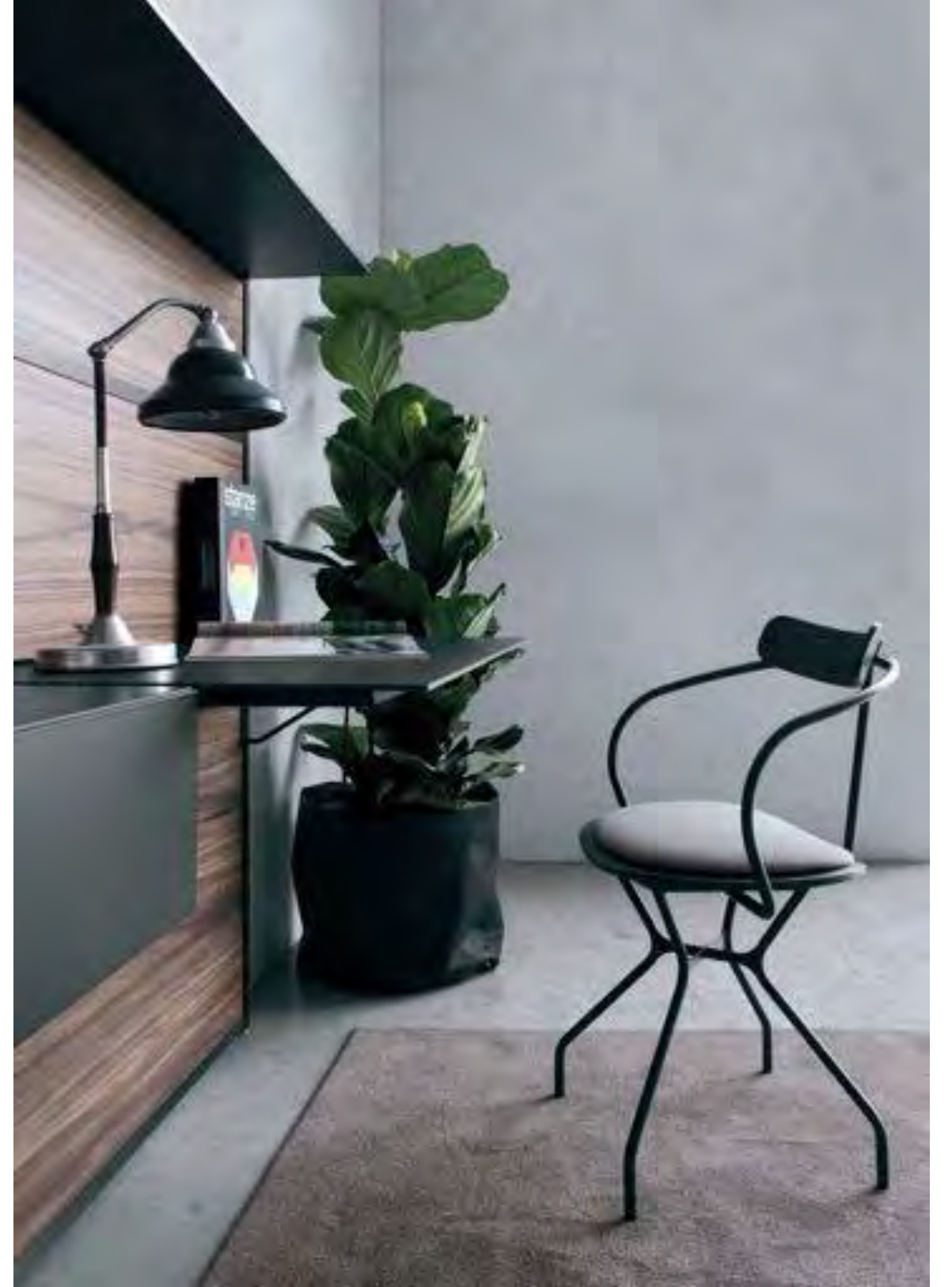

T11 pg. 250



EWS pg. 26

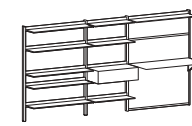

# ECH8

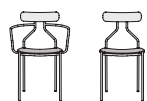

IL FONDELLO DALLA FORMA AMPIA, RICORDA PER DIMENSIONI E GEOMETRIE LE SEDUTE PIÙ CLASSICHE. IL FONDELLO E LO SCHIENALE SONO DISPONIBILI CON RIVESTIMENTO SFODERABILE PER CONSENTIRNE IL LAVAGGIO O L'EVENTUALE RICAMBIO. IL MECCANISMO APPLICATO AGLI SCHIENALI ADATTIVI TRAMITE UN'OSCILLAZIONE CONTROLLATA SEGUE E SOSTIENE IL MOVIMENTO DELLA SCHIENA.

The large seat recalls the more classical seats in terms of dimensions and geometries. The seat and backrest are available with removable upholstery to allow for their washing and changing. The mechanism applied to the adjustable backrests by means of controlled rocking follows and supports the movement of the back.

Le large fond rappelle les sièges plus classiques en termes de taille et de géométrie. Le coussin et le dossier sont disponibles avec des housses amovibles afin d'en permettre le lavage et le remplacement. Le mécanisme appliqué aux dossiers adaptatifs, au moyen d'une oscillation contrôlée, suit et soutient le mouvement du dossier.

Die breite Sitzfläche erinnert durch Größe und Formen an die klassischen Sitzmöbel. Die Sitzfläche und die Rückenlehne sind mit abnehmbarem Polsterzeug verfügbar, um das Waschen und den eventuellen Austausch zu ermöglichen. Der für die adaptiven Rückenlehnen verwendete Mechanismus begleitet und unterstützt durch kontrolliertes Schwanken die Bewegung des Rückens.

El amplio respaldo recuerda en tamaño y geometría a los asientos clásicos. El asiento y el respaldo están disponibles con fundas extraíbles para su lavado o sustitución. El mecanismo aplicado a los respaldos adaptables mediante una oscilación controlada sigue y apoya el movimiento de la espalda.

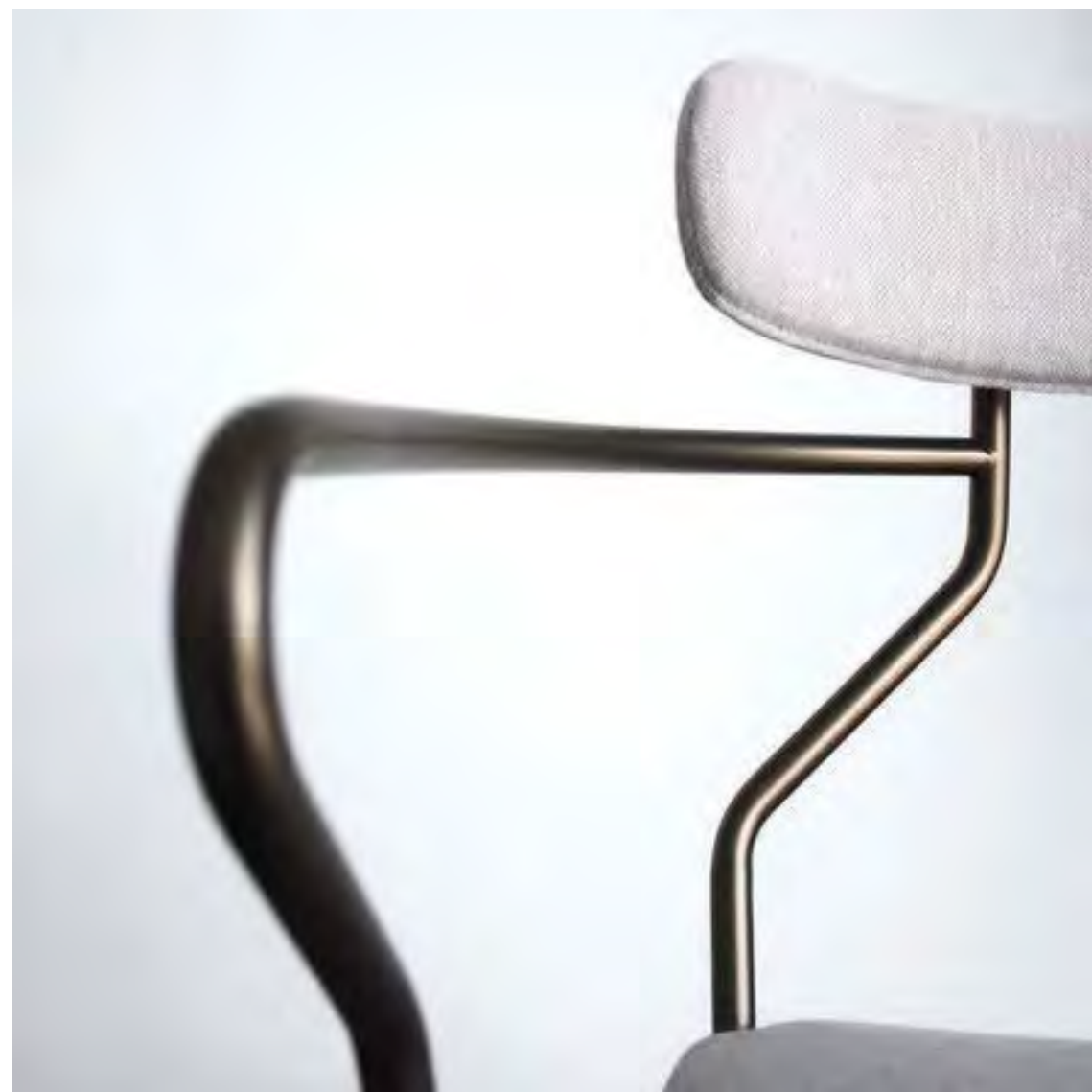

Schienale adattivo  
Adjustable backrest  
Dossier adaptatif  
Adaptive Rückenlehne  
Respaldo adaptable



ADAPTIVE  
CHAIR BACKREST  
registered community  
design



Sfoderabile  
Removable upholstery  
Déhoussable  
Abnehmbares Polsterzeug  
Cubierta desmontable



Piedini intercambiabili  
Interchangeable feet  
Pieds interchangeables  
Austauschbare Füße  
Pies intercambiables

## FINITURE/FINISHES

### fondello e schienale / seat and back

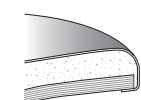

cuoio  
cow-hide



F01  
tabacco  
tobacco

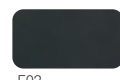

F02  
nero  
black



100% poliestere/polyester  
peso/weight: 400 gr/mq  
BSI : 50.000 cicli/cycles



50% cotone/cotton  
40% poliestere/polyester  
10% poliacrilico/polyacrylic  
peso/weight: 430 gr/mq  
BSI : 40.000 cicli/cycles



60% lino/linen  
40% viscosa/viscose  
peso/weight: 550 gr/mq  
BSI : 20.000 cicli/cycles

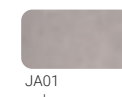

JA01  
perla  
pearl



JA02  
avorio  
ivory

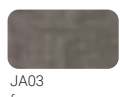

JA03  
fango  
mud

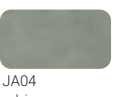

JA04  
salvia  
sage

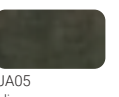

JA05  
oliva  
olive

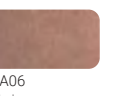

JA06  
cipria  
powder pink



JB01  
natur  
natur

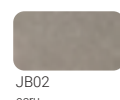

JB02  
ecru  
ecru

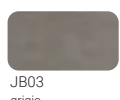

JB03  
grigio  
grey

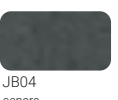

JB04  
cenere  
ash

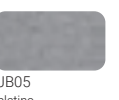

JB05  
platino  
platinum

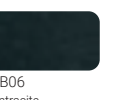

JB06  
antracite  
anthracite



JC01  
fumo  
smoke

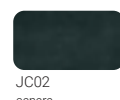

JC02  
cenere  
ash

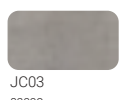

JC03  
sacco  
sack

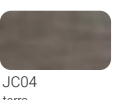

JC04  
terra  
land

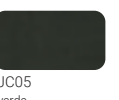

JC05  
verde  
green

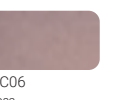

JC06  
rosa  
pink

### telaio / structure

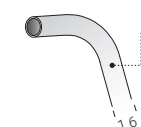

acciaio verniciato  
painted steel



C12  
bianco  
white



C21  
seta  
silk



C23  
corda  
ecru



C30  
ghisa  
cast-iron



C14  
antracite  
anthracite



C08  
nero  
black



C18  
verde  
green



C26  
corten  
corten



C29  
bronzo  
bronze

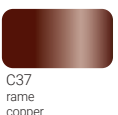

C37  
rame  
copper

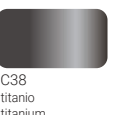

C38  
titanio  
titanium

## DIMENSIONI/DIMENSIONS

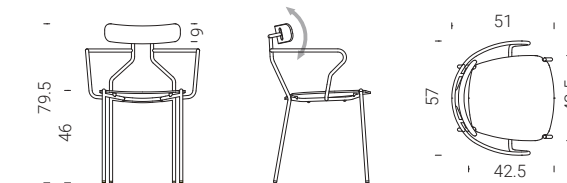

verificare a listino disponibilità, composizione e consigli di lavaggio per i tessuti.  
check availability, composition and washing recommendations for fabrics in the price list.

01/ECH8

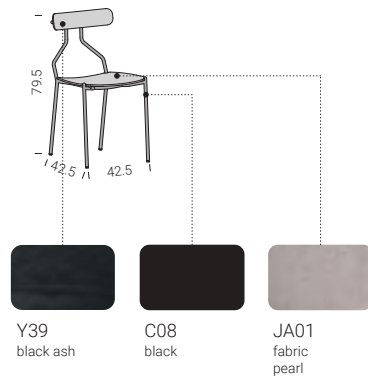

02/ECH8

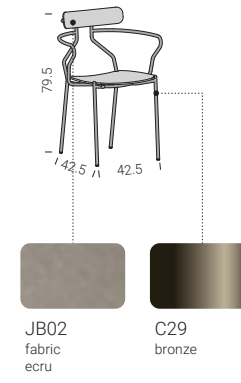

T10 pg. 244

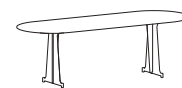

ECH8

- Caratteristiche costruttive
- Construction characteristics
- Caractéristiques de construction
- Konstruktionsmerkmale
- Características constructivas

# ECH9



LA VERSATILITÀ DEL PROGETTO DEL 1927 DI CHARLOTTE PERRIAND PER IL SUO APPARTAMENTO PARIGINO DI PLACE SAINT-SULPICE ISPIRA QUESTA FAMIGLIA DI SEDUTE CARATTERIZZATA DA SCHIENALE ADATTIVO. EXTENDO LA REINTERPRETA DISEGNANDO LA VERSIONE CON BRACCIOLI CHE NE CONSENTE LA COMPLETA ROTAZIONE AL DI SOTTO DEL TOP TAVOLO, AGEVOLANDO L'ACCESSIBILITÀ ALLA SEDUTA.

The versatility of the 1927 project of Charlotte Perriand for his Parisian apartment in Place Saint-Sulpice inspires this family of chairs with adjustable back. Extendo re-interprets it, designing a version with arms that allows full rotation under the table top, facilitating accessibility and seating.

La versatilité du projet de 1927 de Charlotte Perriand pour son appartement parisien de la place Saint-Sulpice inspire cette famille de sièges caractérisée par leur dossier adaptatif. Extendo propose une réinterprétation avec une version à accoudoirs et rotation complète sous le plateau de la table pour faciliter l'accès au siège.

Die Vielseitigkeit des Projekts von 1927 von Charlotte Perriand für sein Pariser Apartment am Place Saint-Sulpice inspiriert diese durch die adaptive Rückenlehne gekennzeichnete Familie von Sitzmöbel. Extendo interpretiert sie neu und entwirft die Version mit Armlehnen, die die komplette Drehung unterhalb der Tischplatte ermöglichen und so das Sitzen erleichtern.

La versatilidad del diseño de Charlotte Perriand de 1927 para su piso parisino de la plaza Saint-Sulpice inspiró esta familia de sillas con respaldo adaptable. Extendo lo reinterpreta diseñando una versión con reposabrazos que le permite girar completamente por debajo del tablero, facilitando el acceso al asiento.



Schienale adattivo  
Adjustable backrest  
Dossier adaptatif  
Adaptive Rückenlehne  
Respaldo adaptable



ADAPTIVE  
CHAIR BACKREST  
registered community  
design



Sfoderabile  
Removable upholstery  
Déhoussable  
Abnehmbares Polsterzeug  
Cubierta desmontable



Piedini intercambiabili  
Interchangeable feet  
Pieds interchangeables  
Austauschbare Füße  
Pies intercambiables

## FINITURE/FINISHES

### fondello e schienale / seat and back

	essenze woods						
		Y36 rovere oak	Y34 noce walnut	Y37 rovere affumicato smoked oak	Y40 frassino argilla clay ash	Y39 frassino nero black ash	
	cuoio cow-hide						
		F01 tabacco tobacco	F02 nero black				
	100% poliestere/polyester peso/weight: 400 gr/mq BSI : 50.000 cicli/cycles						
		JA01 perla pearl	JA02 avorio ivory	JA03 fango mud	JA04 salvia sage	JA05 oliva olive	JA06 cipria powder pink
	50% cotone/cotton 40% poliestere/polyester 10% poliacrilico/polyacrylic peso/weight: 430 gr/mq BSI : 40.000 cicli/cycles						
		JB01 natur natur	JB02 ecru ecru	JB03 grigio grey	JB04 cenere ash	JB05 platino platinum	JB06 antracite anthracite
	60% lino/linen 40% viscosa/viscose peso/weight: 550 gr/mq BSI : 20.000 cicli/cycles						
		JC01 fumo smoke	JC02 cenere ash	JC03 sacco sack	JC04 terra land	JC05 verde green	JC06 rosa pink

### telaio / structure

	acciaio verniciato painted steel						
		C12 bianco white	C21 seta silk	C23 corda ecru	C30 ghisa cast-iron	C14 antracite anthracite	C08 nero black
		C18 verde green	C26 corten corten	C29 bronzo bronze	C37 rame copper	C38 titanio titanium	

## DIMENSIONI/DIMENSIONS

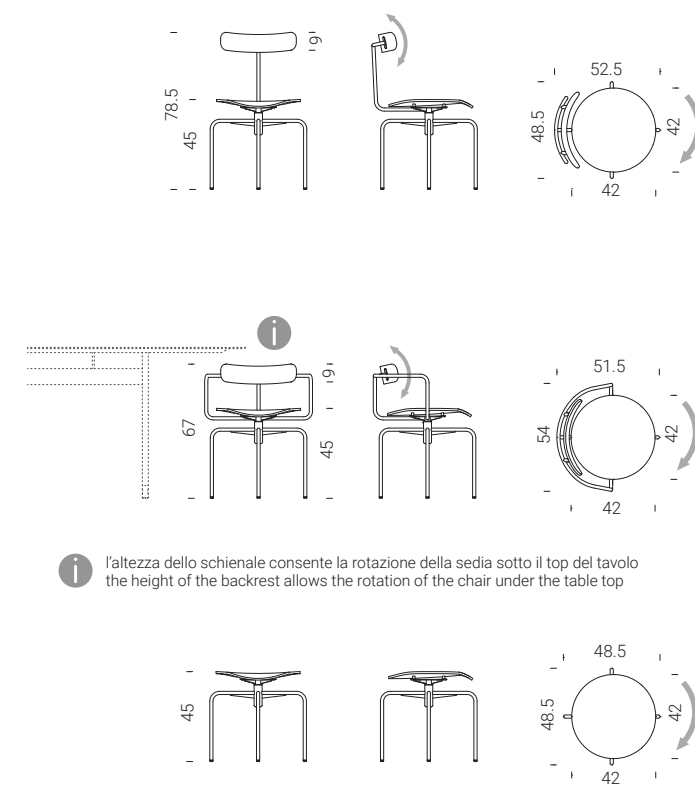

⚠ verificare a listino disponibilità, composizione e consigli di lavaggio per i tessuti.  
check availability, composition and washing recommendations for fabrics in the price list.



01/ECH9

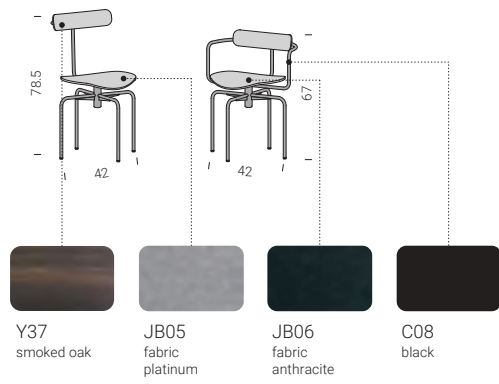

02/ECH9

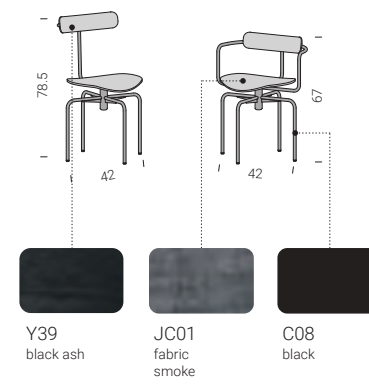

ECH9

- Caratteristiche costruttive
- Construction characteristics
- Caractéristiques de construction
- Konstruktionsmerkmale
- Características constructivas

BALANCE pg. 142



EWS pg. 26



# LAMPS

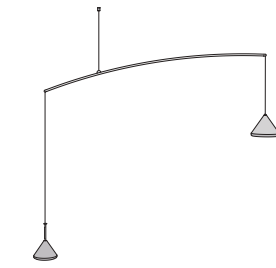

CONTRAPPESO

suspension  
pg. 340

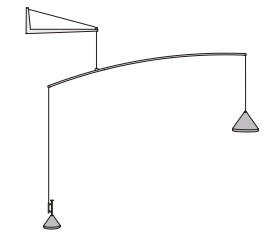

wall  
pg. 344

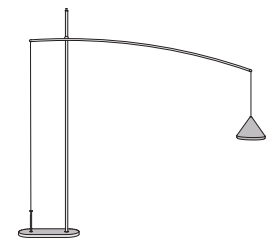

floor  
pg. 345

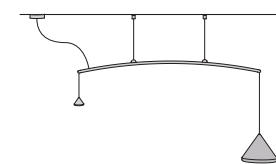

ceiling  
pg. 350

# CONTRAPPESO

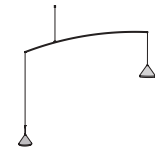

UN CONTRAPPESO IN MARMO O ACCIAIO MANTIENE IN POSIZIONE IL CORPO ILLUMINANTE. AVVOLGENDO IL CAVO ALLA BITTA POSIZIONATA SUL CONTRAPPESO È POSSIBILE REGOLARE IN ALTEZZA LA FONTE LUMINOSA. SPOSTANDO IL CONTRAPPESO, LA FONTE LUMINOSA RUOTA ATTORNO AL PUNTO DI SOSPENSIONE CONSENTENDO DI RAGGIUNGERE PUNTI LONTANI DALLA PRESA ELETTRICA.

A marble or steel counterweight keeps the lighting fixture in position. By winding the cable around the bitt on the counterweight it is possible to adjust the height of the lighting fixture. Moving the counterweight, the light source rotates around the suspension point, allowing points further away from the electrical output to be reached.

Un contrepoids en marbre ou en acier maintient le corps lumineux en position. Il est possible de régler la hauteur du corps lumineux en enroulant le câble autour de la borne positionnée sur le contrepoids. En déplaçant le contrepoids, la source lumineuse tournera autour du point de suspension, permettant ainsi d'atteindre des points éloignés de la prise électrique.

Ein Gegengewicht aus Marmor oder Stahl hält den Leuchtkörper in Position. Wenn man den Kabel um den Poller auf dem Gegengewicht wickelt, kann man die Höhe des Leuchtkörpers einstellen. Durch Verlegung des Gegengewichts dreht sich die Lichtquelle um den Schwebepunkt und so können auch die von der Steckdose entfernten Punkte erreicht werden.

Un contrapeso de mármol o acero mantiene la luminaria en su sitio. Enrollando el cable alrededor del bolardo del contrapeso, se puede ajustar la altura de la luminaria. Moviendo el contrapeso, la fuente de luz gira alrededor del punto de suspensión, lo que permite llegar a lugares alejados de la toma de corriente.

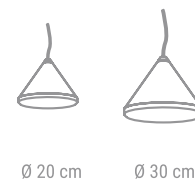

Led Module: SMD LED  
MOUNTED ON MODULE CLE 160 mm. ADV4  
Lumen: 3100 lm  
Power: 650 mA  
INPUT: 220 - 240 V | 50/60 Hz  
Color temperature: 3000 K  
Dimming range 1 - 100 %  
CRI: >80



Led Module: SMD LED  
MOUNTED ON MODULE CLE 315 mm. ADV4  
Lumen: 4200 lm  
Power: 900 mA  
INPUT: 220 - 240 V | 50/60 Hz  
Color temperature: 3000 K  
Dimming range 1 - 100 %  
CRI: >80

## FINITURE/FINISHES

### struttura / structure



### basamento / basement

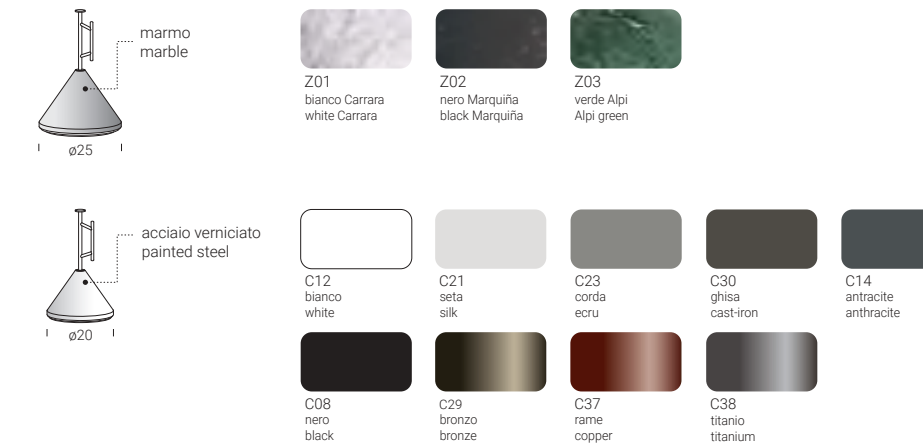

## DIMENSIONI/DIMENSIONS

verificare a listino geometrie e finiture  
check geometries and finishes in the price list

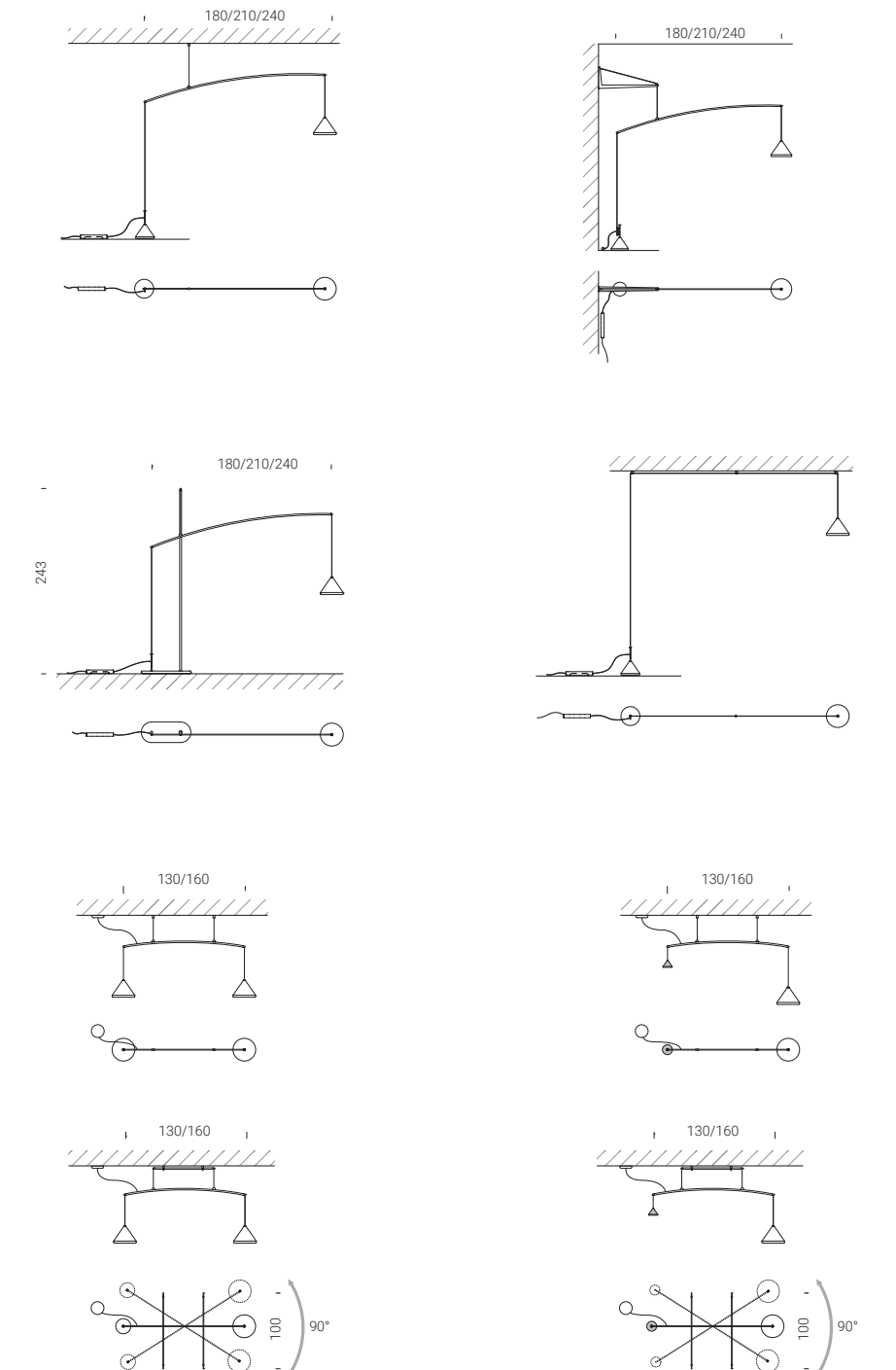

04/CONTRAPPESO

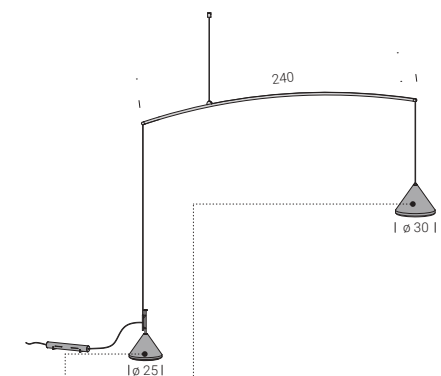

Z02  
marble  
black Marquina



C08  
black

SPIILLO [pg. 172](#)



ATELIER [pg. 46](#)

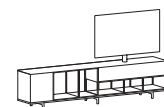

CONTRAPPESO

- Caratteristiche costruttive
- Construction characteristics
- Caractéristiques de construction
- Konstruktionsmerkmale
- Características constructivas



01/CONTRAPPESO

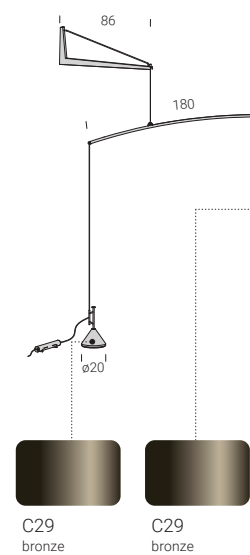

02/CONTRAPPESO

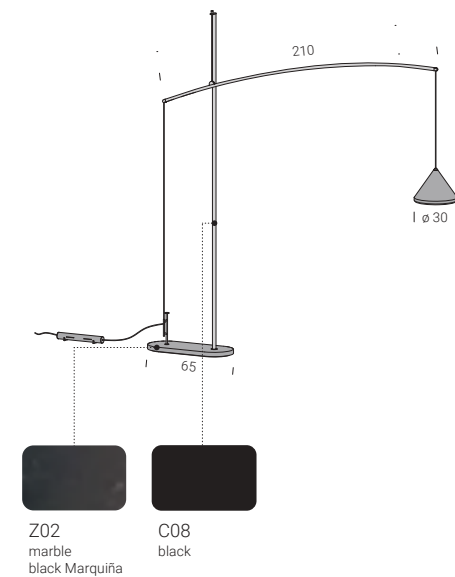

ECH6 pg. 318



03/CONTRAPPESO

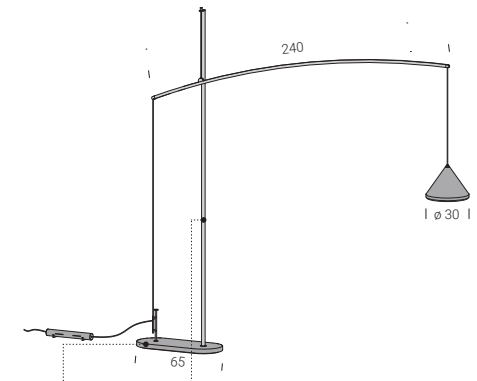

Z02  
marble  
black Marquina

C08  
black



ST35 pg. 186

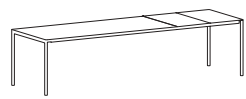

05/CONTRAPPESO

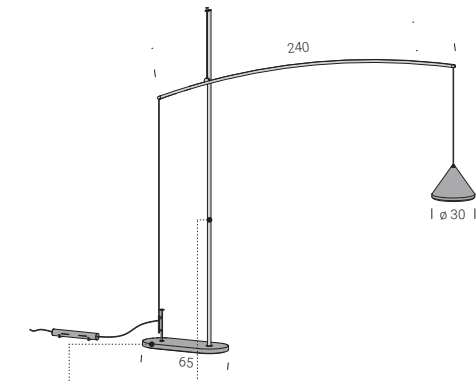

Z01  
marble  
white Carrara

C12  
white



T9 pg. 234

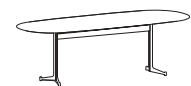

09/CONTRAPPESO

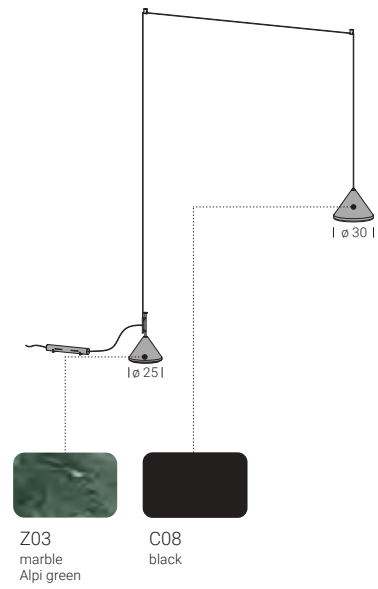

T7 pg. 218



EWS pg. 26



08/CONTRAPPESO

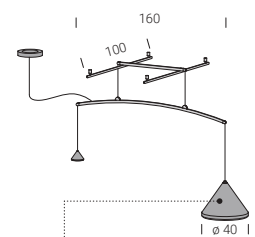

C08  
black

ECH3 pg. 302



ST35 pg. 186

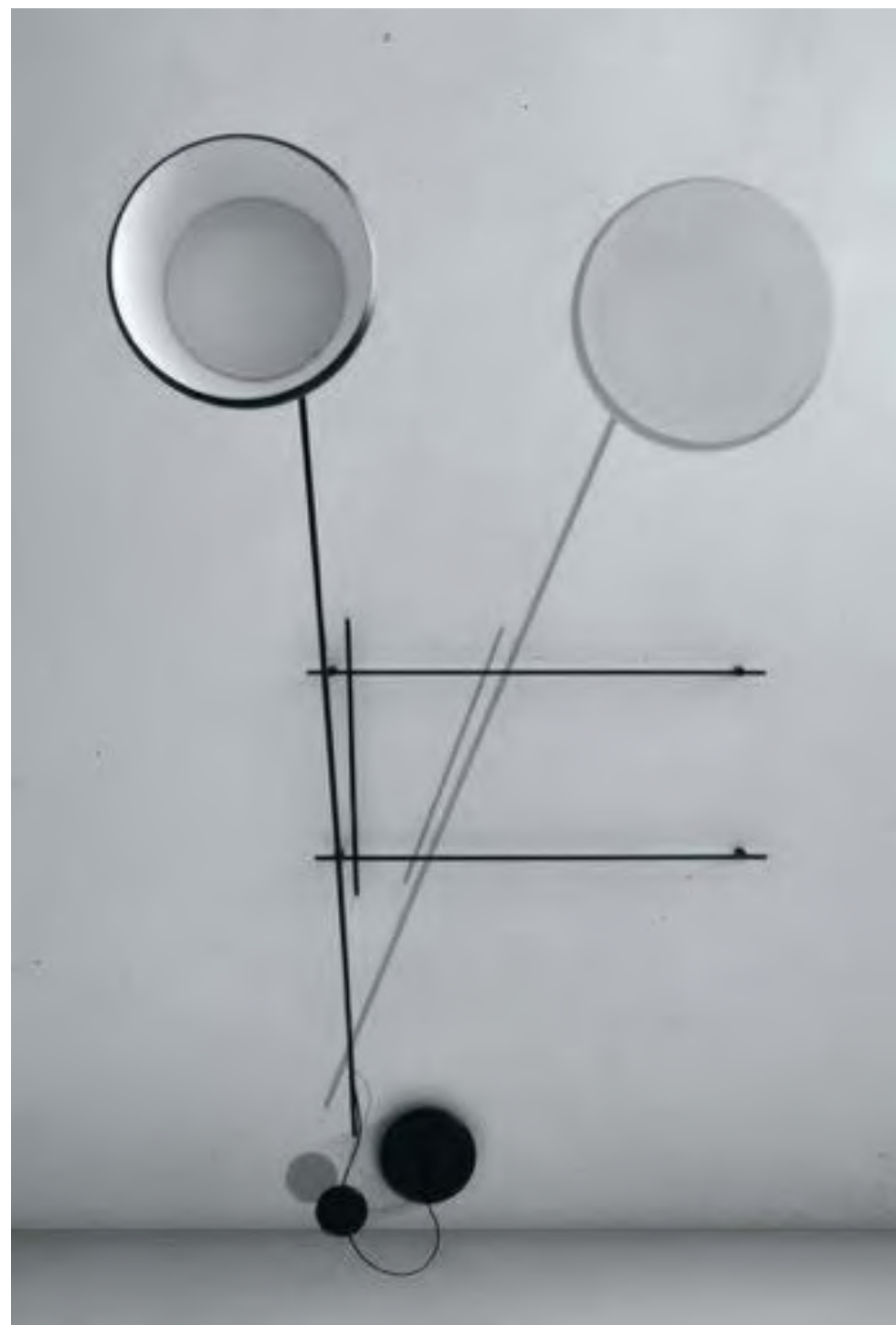
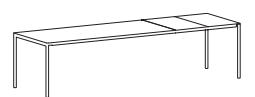



06/CONTRAPPESO

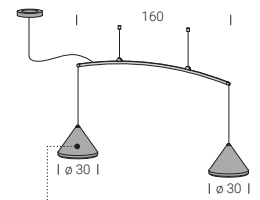

C08  
black

BALANCE pg.142



SYSTEM pg.120

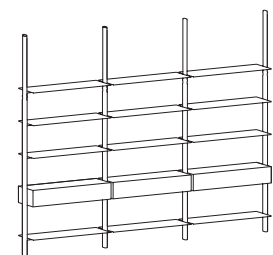

07/CONTRAPPESO

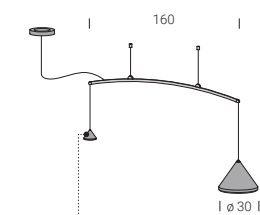

C08  
black

ECH4 pg. 308



T11 pg. 250



SYSTEM pg. 120

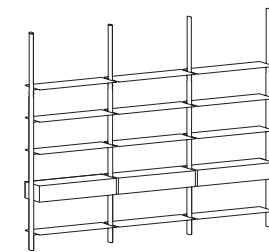

# MULTIMEDIA

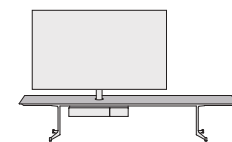

CONNECT  
tv dimension: 40" - 85"  
pg. 356

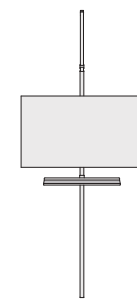

SYSTEM  
MULTIMEDIA  
tv dimension: 40" - 65"  
pg. 376

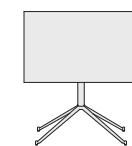

APOLLO  
tv dimension: 40" - 65"  
pg. 364

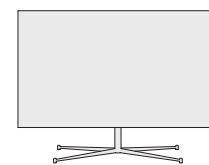

TITANO  
tv dimension: 55" - 85"  
pg. 382

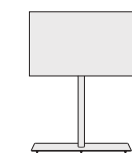

SPIN 360  
tv dimension: 40" - 65"  
pg. 370

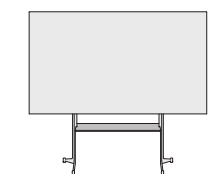

URANO  
tv dimension: 55" - 85"  
pg. 388

# CONNECT

tv dimension: 40" - 85"

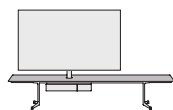

SUPPORTO PENSATO PER INSTALLARE LE TV DI NUOVA GENERAZIONE A PARETE O IN CENTRO STANZA CON LA MASSIMA FLESSIBILITÀ. IL SISTEMA DI INTEGRAZIONE CAVI STUDIATO DA EXTENDO CONSENTE DI NASCONDERE COMPLETAMENTE I CAVI LASCIANDO LIBERTÀ DI ROTAZIONE DI 360° DELLA TV. IL SUPPORTO ROTANTE E IL CONTENIMENTO DI APPARATI MULTIMEDIALI NELLA PARTE SOTTOSTANTE SONO ACCESSORI.

This is a TV support column designed to host new generation TV installations either mounted on the wall or in the centre of the room with the utmost flexibility. The cable integration system designed by extendo makes it possible to completely conceal cables enabling the TV to freely rotate a full 360°. The turntable swivel base and the multimedia device cable containment system in the lower part of the support column are accessories.

Support conçu pour installer les téléviseurs de nouvelle génération au mur ou au centre de la pièce avec une flexibilité maximale. Le système d'intégration des câbles, conçu par extendo, permet de cacher complètement les câbles en laissant la liberté de rotation de 360° du téléviseur. Le support pivotant et le récipient pour appareils multimédias dans la partie en dessous sont des accessoires.

Fernsehalterung für die Installation von TV-Geräten der neuesten Generation an der Wand oder in der Raummitte, für maximale Flexibilität bei der Positionierung. Dank der von extendo entwickelten, integrierten Kabelführung lassen sich die Gerätekabel völlig verstecken, wobei das Gerät um 360 Grad schwenkbar bleibt. Die Drehhalterung und die unterhalb anzubringenden Fächer für Multimedia-Geräte sind als Zubehör erhältlich.

Soporte pensado para instalar televisores de nueva generación en la pared o en una posición central en el ambiente, con la máxima flexibilidad. El sistema de integración de cables estudiado por extendo, permite ocultar los cables por completo, dejando libertad de rotación de 360° para el televisor. Cuenta con accesorios en la parte de abajo: un soporte giratorio y un espacio para posicionar dispositivos multimedia.



i cavi della TV e di eventuali unità multimediali sono completamente nascosti.

the TV and multimedia unit wires are completely hidden.

les fils de la TV et des unités multimédias sont complètement dissimulés.

Die Kabel des Fernsehers und der Multimedia sind vollkommen unsichtbar.

los cables de la TV y de los sistemas multimedia quedan completamente ocultos.



supporto monitor universale per TV da 40 a 85 pollici. universal monitor support for TV from 40 to 85 inches.

support moniteur universel pour TV de 40 à 85 pouces.

Universal-Monitor-Halter für TV von 40 bis 85 Zoll.

soporte de monitor universal para TV de 40 a 85 pulgadas.

## FINITURE/FINISHES

top

0.6	0.3	POLARIS®	L03 bianco white	L10 grigio chiaro light grey	L11 grigio scuro dark grey			
0.6	0.3	FENIX®	L08 grigio Londra London grey	L06 nero black				
0.7	0.3	HPL + legno HPL + wood	Y36 rovere oak	Y34 noce walnut	Y37 rovere affumicato smoked oak	Y40 frassino argilla clay ash	Y39 frassino nero black ash	
0.7	0.3	HPL + metallo HPL + metal	C31 ottone brass	C32 ottone scuro dark brass	C35 inox inox	C36 inox scuro dark inox		
0.7	0.3	HPL + ecotouch	N01 sabbia sand	N02 basalto basalt				
0.7	0.3	HPL + cemento HPL + cement	D01 bianco calce lime white	D02 grigio Portland Portland grey	D03 nero black			
0.6		ceramica ceramic	S05 antracite anthracite	S06 nero black	S07 porfido porfido	S08 cardoso cardoso		

telaio / structure

1.8	acciaio verniciato painted steel	C12 bianco white	C21 seta silk	C23 corda ecru	C30 ghisa cast-iron	C14 antracite anthracite
		C08 nero black	C18 verde green	C26 corten corten	C29 bronzo bronze	C37 rame copper
		C38 titanio titanium				

## DIMENSIONI/DIMENSIONS

verificare a listino geometrie e finiture  
check geometries and finishes in the price list

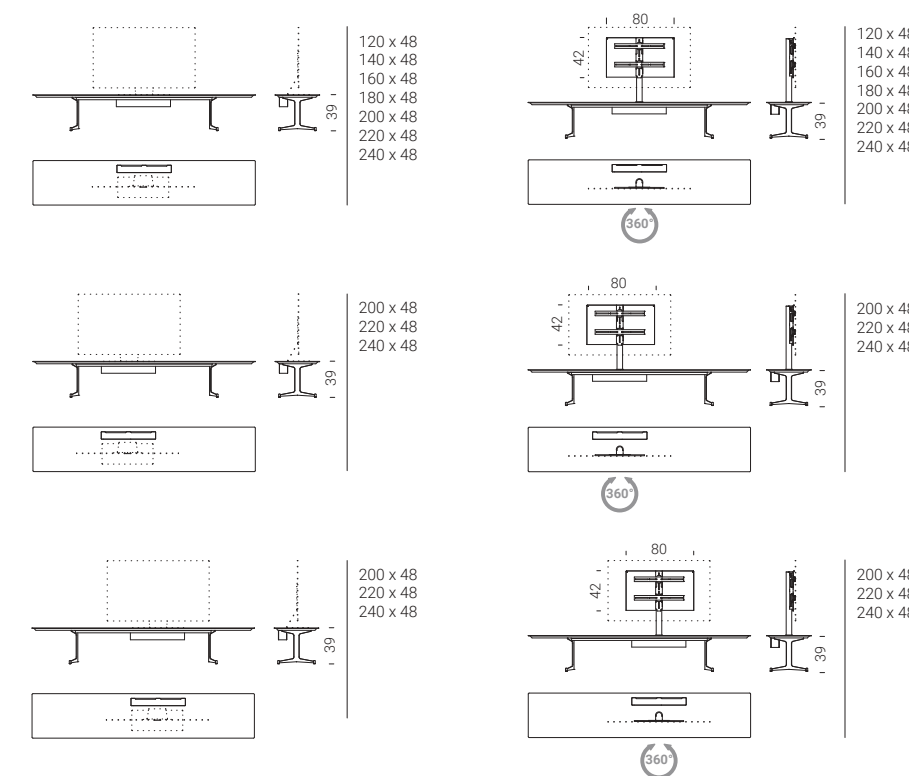

accessori / accessories

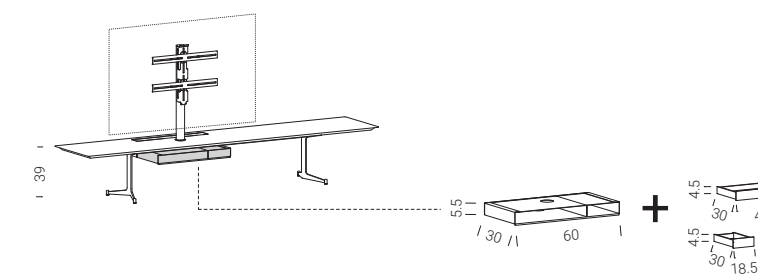

01/CONNECT

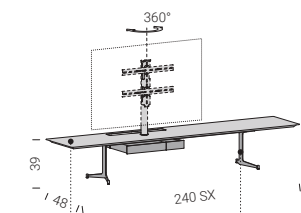

Y39  
black ash

C08  
black





02/CONNECT

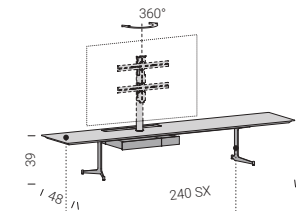

Y39  
black ash



C08  
black



DÉCO pg. 272



ATELIER pg. 46

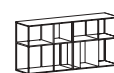

# APOLLO

tv dimension: 40" - 65"

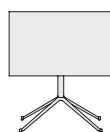

DESIDERAVAMO DISEGNARE UN SUPPORTO CHE SI INTEGRASSE AL MEGLIO CON IL DESIGN ESSENZIALE DEGLI ULTIMI MODELLI TV. APOLLO PUR ESSENDO COMPOSTO DA POCHI ELEMENTI CHE NE EVIDENZIANO LA PUREZZA GEOMETRICA, CONSENTE LA ROTAZIONE DI 360°, L'OCCULTAMENTO DEI CAVI E LA POSSIBILITÀ DI AGGIUNGERE ACCESSORI PORTA DECODER E SOUND BAR.

We had the intention to design a TV support column that integrates at best with the essential design of the latest TV models. Although Apollo consists of only a few elements that enhance its geometrical purity, it rotates 360°, the concealing of cables along with the possibility to add TV decoder and sound bar support accessories.

Nous souhaitons dessiner un support qui s'intègre au mieux avec le design essentiel des derniers modèles de téléviseurs. Apollo, même s'il est composé de peu d'éléments qui mettent en évidence sa pureté géométrique, permet la rotation de 360°, la dissimulation des câbles et la possibilité d'ajouter des accessoires comme le porte-décodeur et la barre audio.

Unser Anliegen bestand darin, einen Fernsehständer zu entwerfen, der optimal auf das essentielle Design der neuesten TV-Modelle abgestimmt ist. Apollo setzt auf einen essentiellen Aufbau aus wenigen Elementen und besticht durch eine schlichte Optik. Er erlaubt eine Drehung des Geräts um 360 Grad, bietet unsichtbare Kabelverlegung und auf Wunsch zusätzliche Ablagen für Decoder und Soundbar als Zubehör.

Nuestro deseo era diseñar un soporte que se integrara de la mejor forma con el diseño esencial de los últimos modelos de televisores. Apollo, que consta de pocos elementos que ponen de relieve su pureza geométrica, permite la rotación de 360°, ocultar los cables y la posibilidad de añadir accesorios porta codificador y barra de sonido.



i cavi della TV e di eventuali unità multimediali sono completamente nascosti.

the TV and multimedia unit wires are completely hidden.

les fils de la TV et des unités multimédias sont complètement dissimulés.

Die Kabel des Fernsehers und der Multimedia sind vollkommen unsichtbar.

los cables de la TV y de los sistemas multimedia quedan completamente ocultos.



supporto monitor universale per TV da 40 a 65 pollici.

universal monitor support for TV from 40 to 65 inches.

support moniteur universel pour TV de 40 à 65 pouces.

Universal-Monitor-Halter für TV von 40 bis 65 Zoll.

soporte de monitor universal para TV de 40 a 65 pulgadas.



Rotazione 360°

Rotation 360°

Rotation 360°

Rotation 360°

Rotación 360°

## FINITURE/FINISHES

verificare a listino dimensioni e finiture  
check dimensions and finishes in the price list

telaio / structure

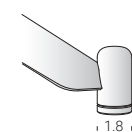

acciaio verniciato  
painted steel



C12  
bianco  
white



C21  
seta  
silk



C23  
corda  
ecru



C30  
ghisa  
cast-iron



C14  
antracite  
anthracite



C08  
nero  
black

## DIMENSIONI/DIMENSIONS

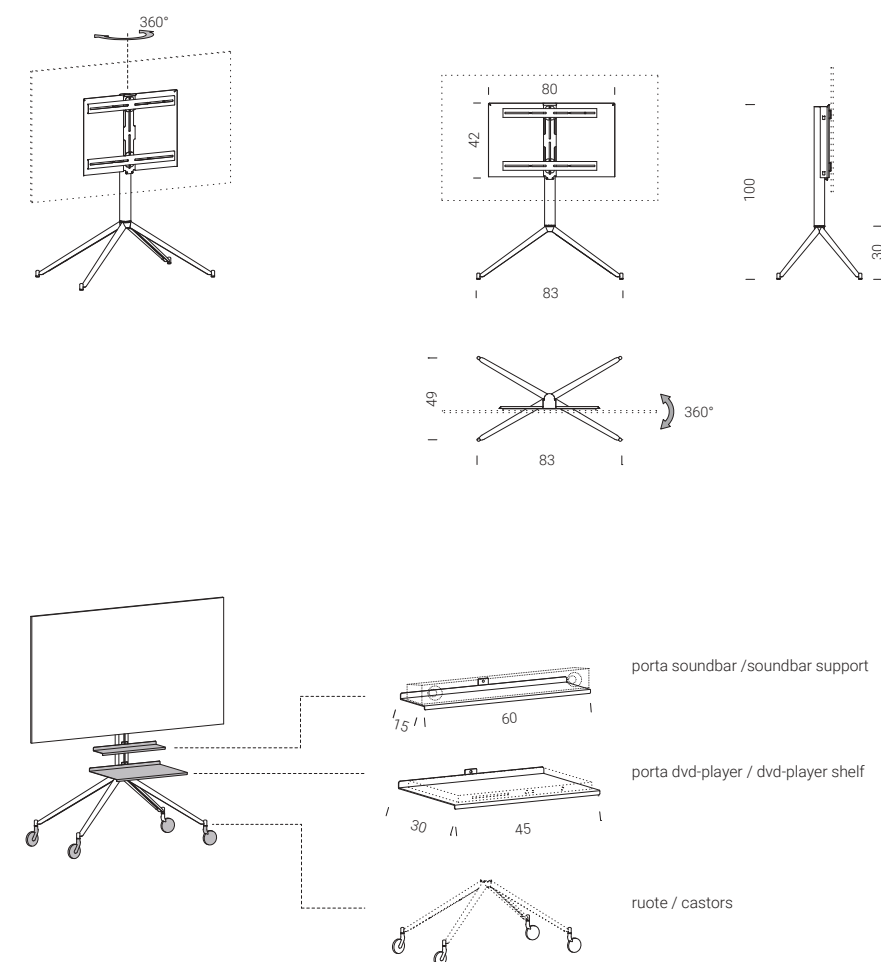

porta soundbar /soundbar support

porta dvd-player / dvd-player shelf

ruote / castors

02/APOLLO

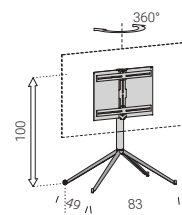

C14  
anthracite



APOLLO

- Caratteristiche funzionali
- Functional characteristics
- Caractéristiques fonctionnelles
- Funktionale merkmale
- Características funcionales







# SPIN 360

tv dimension: 40" - 65"



SPIN 360 È UN SUPPORTO TV DISEGNATO E PROGETTATO PER UNA PERFETTA INTEGRAZIONE CON I MONITOR DAL DESIGN PIÙ SOFISTICATO. NASCONDERE I CAVI COMPLETAMENTE AL SUO INTERNO E ORIENTARE LA COLONNA A 360 GRADI, GARANTISCE MASSIMA FUNZIONALITÀ E PUREZZA DI DISEGNO. SPIN 360 È DISPONIBILE NELLA VERSIONE CON BASE IN ACCIAIO SPESSORE 6MM, CON CONTENITORE PER UNITÀ MULTIMEDIALI APERTO O CHIUSO, IN DUE ALTEZZE DISTINTE H=100 / 120 CM.

Spin 360 is a TV support designed and manufactured for perfect integration with the most sophisticated monitor designs. It completely hides wires within and the column can be turned 360 degrees, guaranteeing maximum functionality and clean design. Spin 360 is available in a version with a 6mm thick steel base, with a container for multimedia units opened or closed, in two distinct heights H=100 / 120 cm.

Spin 360 est un support pour TV dessiné et conçu pour une intégration parfaite avec les écrans aux designs les plus sophistiqués. Pour un maximum de fonctionnalité et de pureté du dessin dissimuler les fils complètement à l'intérieur et orienter la colonne à 360°. Spin 360 est disponible dans la version avec base en acier, épaisseur 6 mm, avec module de rangement pour unités multimédias ouvert ou fermé, disponible dans deux hauteurs distinctes H=100/120 cm.

Spin 360 ist ein TV-Halter, der für eine perfekte Integration von hoch entwickelten Bildschirmen entworfen wurde. Die vollständige Unterbringung der Kabel im Halter und die Drehmöglichkeit der Säule um 360 Grad, bieten höchste Zweckmäßigkeit und ein klares Design. Spin 360 ist in der Version mit einem Fuß aus 6 mm starkem Stahl, einer multimedialen, offenen oder geschlossenen Einheit, in zwei unterschiedlichen Höhen von 100 oder 120 cm erhältlich.

Spin 360 es un soporte de TV diseñado y desarrollado para una integración perfecta con la pantalla de diseño más sofisticado. Ocultar los cables completamente en su interior y orientar la columna a 360 grados, garantiza la máxima durabilidad y la pureza del diseño. Spin 360 está disponible en versión con base de acero de 6 mm de grosor, con compartimento para sistemas multimedia abierto o cerrado, en dos alturas diferentes H = 100/120 cm.



i cavi della TV e di eventuali unità multimediali sono completamente nascosti.  
the TV and multimedia unit wires are completely hidden.

les fils de la TV et des unités multimédias sont complètement dissimulés.

Die Kabel des Fernsehers und der Multimedia sind vollkommen unsichtbar.

los cables de la TV y de los sistemas multimedia quedan completamente ocultos.



supporto monitor universale per TV da 40 a 65 pollici.  
universal monitor support for TV from 40 to 65 inches.

support moniteur universel pour TV de 40 à 65 pouces.

Universal-Monitor-Halter für TV von 40 bis 65 Zoll.

soporte de monitor universal para TV de 40 a 65 pulgadas.



Rotazione 360°  
Rotation 360°  
Rotation 360°  
Rotación 360°

## FINITURE/FINISHES

verificare a listino dimensioni e finiture  
check dimensions and finishes in the price list

telaio / structure



acciaio verniciato  
painted steel



C12  
bianco  
white



C21  
seta  
silk



C23  
corda  
ecru



C30  
ghisa  
cast-iron



C14  
antracite  
anthracite



C08  
nero  
black

## DIMENSIONI/DIMENSIONS

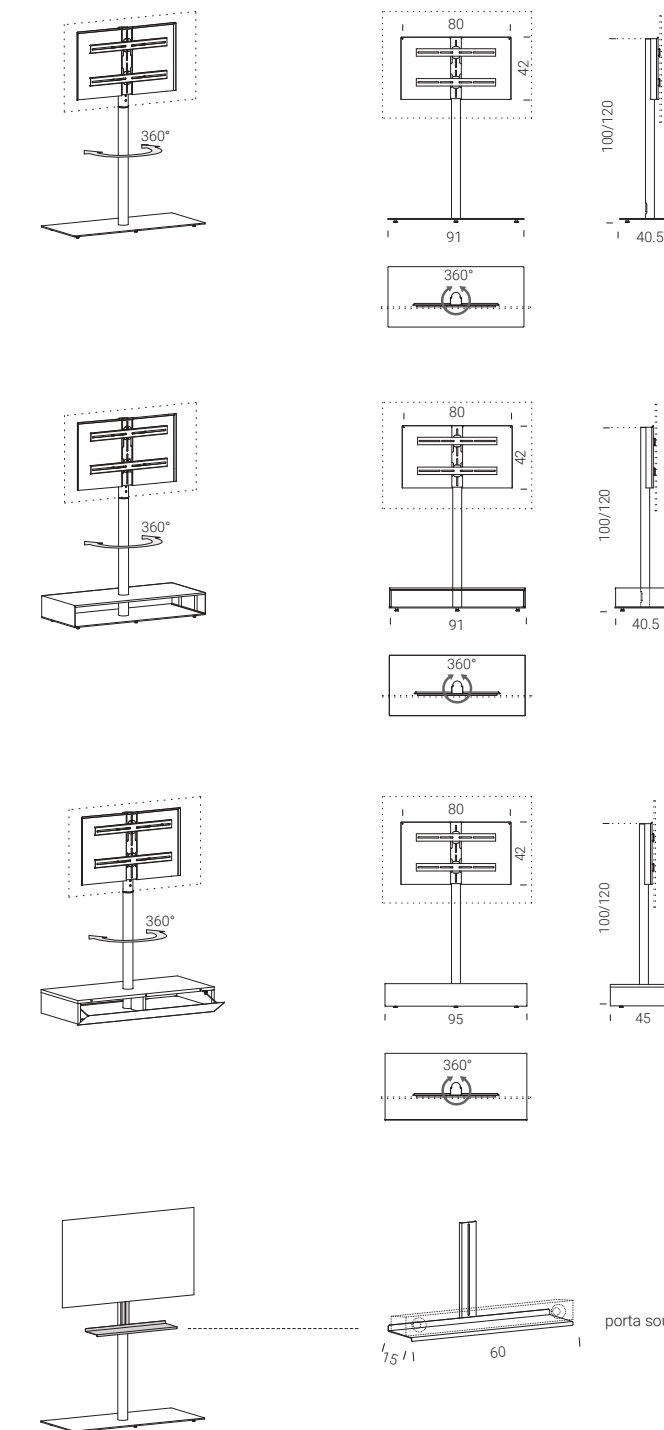

porta soundbar /soundbar support

01/SPIN360

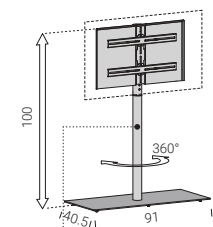

C08  
black





- SPIN360**
- Caratteristiche funzionali
  - Functional characteristics
  - Caractéristiques fonctionnelles
  - Funktionale merkmale
  - Características funcionales



# SYSTEM MULTIMEDIA

tv dimension: 40" - 65"

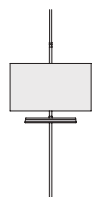

L'ASTA TELESCOPIA EXTENDO E IL PROFILO A PARETE EXTENDO, SONO PRODOTTI ACCESSORIABILI CON STAFFA SUPPORTO MONITOR UNIVERSALE, RIPIANI PER UNITÀ MULTIMEDIALI, RIPIANI PER LIBRI, RIVISTE, DVD, CD. LE CLIP FERMA-CAVI IN DOTAZIONE CON LA STAFFA MONITOR CONSENTO DI EFFETTUARE IL CABLAGGIO ALL'ESTERNO DEL PROFILO.

The Extendo telescopic pole and Extendo wall profile are products easily accessorised with a universal monitor support bracket, shelving for multimedia units or shelving for books, magazines, DVDs and CDs. The cable-tie clips supplied with the monitor bracket enable wiring outside the profile.

La tige télescopique extendo et le profilé mural extendo sont des produits pouvant être équipés de fixation de support de moniteur universel, d'étagères pour unités multimédia, d'étagères pour livres, revues, DVD, CD. Le clip serre-câble fourni avec la fixation de support de moniteur permet d'effectuer le câblage à l'extérieur du profilé.

Die extendo Teleskopstange und das extendo Wandprofil, können mit Universal-Monitor-Halter, Fächer für multimediale Geräte, Fächer für Bücher, Zeitschriften, DVD und CD ausgestattet werden. Die zusammen mit dem Monitorhalter gelieferte Kabelklemmen ermöglichen die Verkabelung an der Außenseite des Profils.

La barra telescópica extendo y el perfil de sujeción a pared extendo son productos equipables con accesorios como el soporte de monitor universal o los estantes para libros, revistas, DVD o CD. El clip sujetacables que viene con el soporte de monitor permite efectuar el cableado por fuera del perfil.



supporto monitor universale per TV da 40 a 65 pollici.  
universal monitor support for TV from 40 to 65 inches.  
support moniteur universel pour TV de 40 à 65 pouces.  
Universal-Monitor-Halter für TV von 40 bis 65 Zoll.  
soporte de monitor universal para TV de 40 a 65 pulgadas.



Rotazione 160°  
Rotation 160°  
Rotation 160°  
Rotación 160°

## FINITURE/FINISHES

verificare a listino dimensioni e finiture  
check dimensions and finishes in the price list

telaio / structure

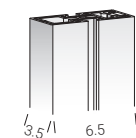

alluminio verniciato  
painted aluminium



C12  
bianco  
white



C21  
seta  
silk



C30  
ghisa  
cast-iron



C08  
nero  
black



C29  
bronzo  
bronze

accessori / accessories



acciaio verniciato  
painted steel



C12  
bianco  
white



C21  
seta  
silk



C30  
ghisa  
cast-iron



C08  
nero  
black



C29  
bronzo  
bronze

## DIMENSIONI/DIMENSIONS

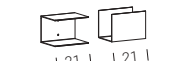
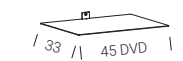
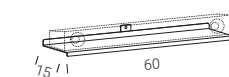
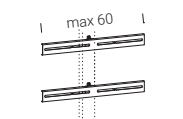
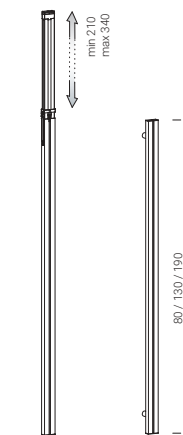

55/SYSTEM MULTIMEDIA

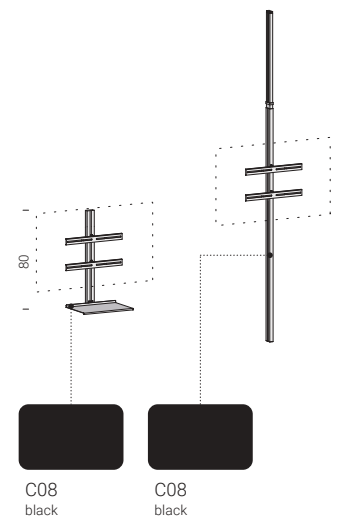

SYSTEM MULTIMEDIA

- ▶ Caratteristiche funzionali
- ▶ Functional characteristics
- ▶ Caractéristiques fonctionnelles
- ▶ Funktionale merkmale
- ▶ Características funcionales

SILLO pg. 172



VIKING pg. 294



SINTESI pg. 174

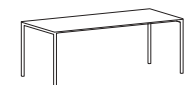

23/SYSTEM MULTIMEDIA

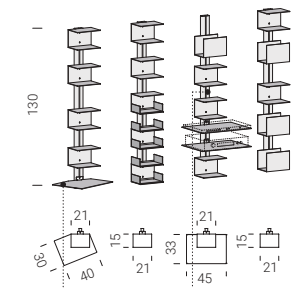

C08  
black

C08  
black



# TITANO

tv dimension: 55" - 85"

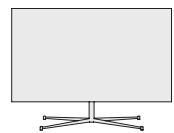

TITANO PERMETTE L'INSTALLAZIONE DI MONITOR DAI 55" AGLI 85". I CAVI SONO COMPLETAMENTE OCCULTATI ALL'INTERNO DELLA COLONNA LIBERAMENTE ORIENTABILE A 360°. UNA COPPIA DI CARTER POSTERIORI NASCONDE E DÀ ACCESSO RAPIDO ALLE PRESE DELLA TV. È ACCESSORIABILE CON UN SUPPORTO PER SOUND-BAR O LETTORI MULTIMEDIALI CHE INTEGRA E CELA COMPLETAMENTE I CAVI.

Titano allows the installation of monitors of a size from 55" to 85". The cables are completely hidden by the freely and fully orientable stand. A pair of back covers hides and allows rapid access to the TV electrical outlets. It can be accessorized with a sound-bar or multimedia readers support that completely incorporates and conceals the cables.

Titano permet l'installation de télévisions allant de 55 à 85 pouces. Les câbles sont complètement dissimulés à l'intérieur de la colonne, laquelle peut pivoter librement sur 360°. Deux panneaux de protection arrière permettent de dissimuler et d'accéder rapidement aux prises TV. Des accessoires tels qu'un support pour barres de son ou lecteurs multimédias peuvent être ajoutés, avec incorporation et dissimulation complètes des câbles.

Titano ermöglicht die Montage von Bildschirmen von 55" bis zu 85". Die Kabel sind komplett in der um 360° frei drehbaren Säule versteckt. Zwei Gehäuse auf der Rückseite verstecken und ermöglichen den leichten Zugriff zu den TV-Steckdosen. Er kann mit einer Unterlage für Sound-Bar oder multimedialen Playern ausgestattet werden, die die Kabel integriert und komplett versteckt.

Los cables están completamente ocultos dentro de la columna ajustable de 360°. Un par de tapas traseras ocultan y dan acceso rápido a las tomas de televisión. Puede equiparse con un soporte para barras de sonido o reproductores multimedia que integra y oculta completamente los cables.

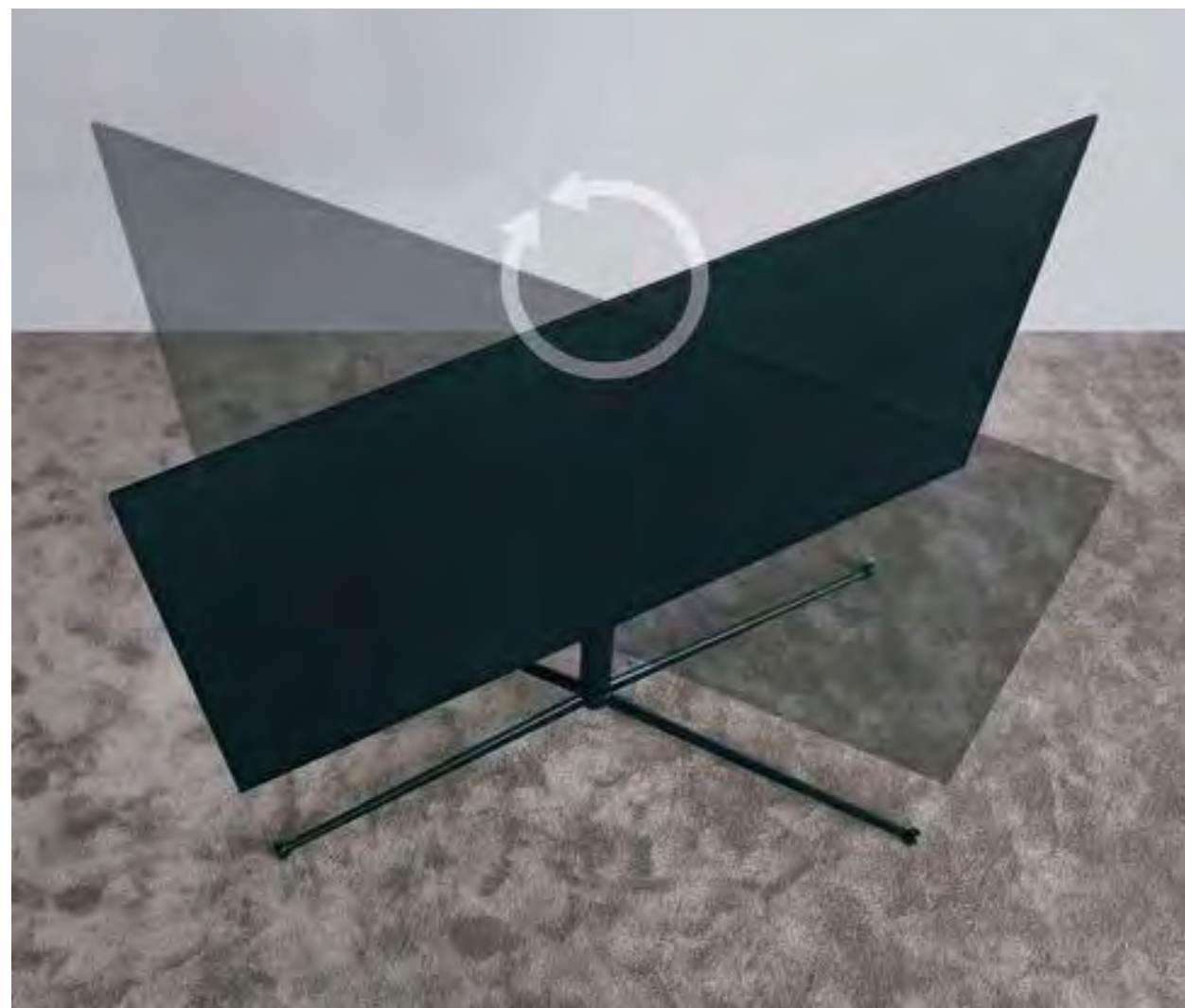

i cavi della TV e di eventuali unità multimediali sono completamente nascosti.

the TV and multimedia unit wires are completely hidden.

les fils de la TV et des unités multimédias sont complètement dissimulés.

Die Kabel des Fernsehers und der Multimedia sind vollkommen unsichtbar.

los cables de la TV y de los sistemas multimedia quedan completamente ocultos.



supporto monitor universale per TV da 55 a 85 pollici.

universal monitor support for TV from 55 to 85 inches.

support moniteur universel pour TV de 55 à 85 pouces.

Universal-Monitor-Halter für TV von 55 bis 85 Zoll.

soporte de monitor universal para TV de 55 a 85 pulgadas.



Rotazione 360°

Rotation 360°

Rotation 360°

Rotación 360°

Rotación 360°

## FINITURE/FINISHES

verificare a listino dimensioni e finiture  
check dimensions and finishes in the price list

telaio / structure

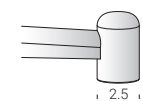

acciaio verniciato  
painted steel



C12  
bianco  
white

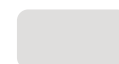

C21  
seta  
silk



C23  
corda  
ecru



C30  
ghisa  
cast-iron



C14  
antracite  
anthracite



C08  
nero  
black

## DIMENSIONI/DIMENSIONS

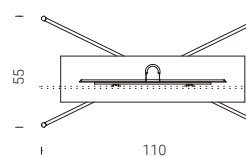
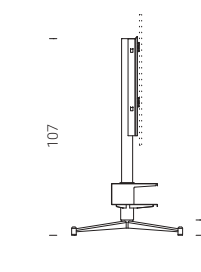
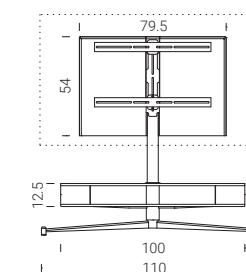
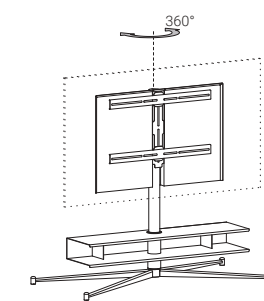
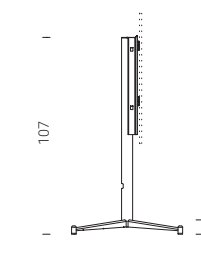
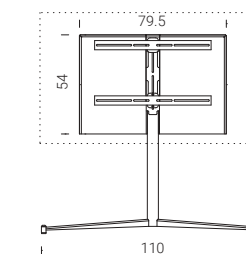
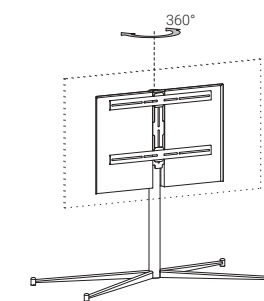



01/TITANO

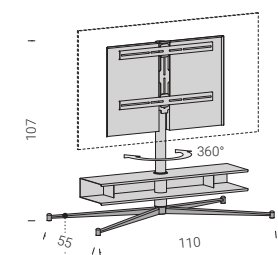

C08  
black



TITANO

- Caratteristiche funzionali
- Functional characteristics
- Caractéristiques fonctionnelles
- Funktionale merkmale
- Características funcionales

02/TITANO

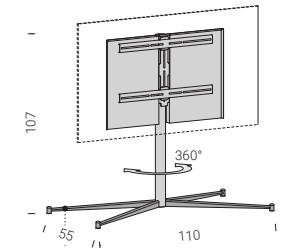

C08  
black

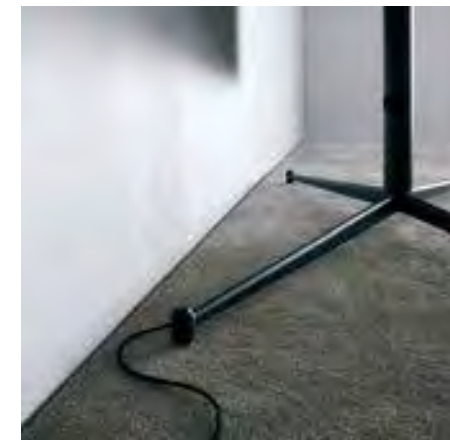
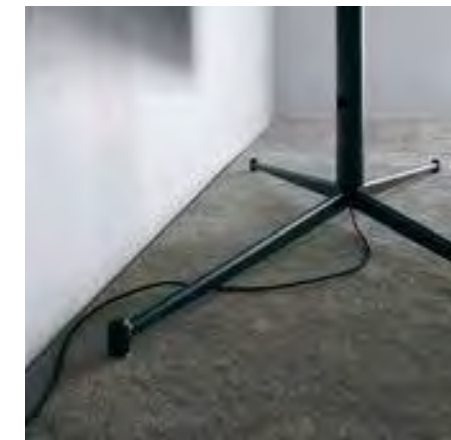

# URANO

tv dimension: 55" - 85"

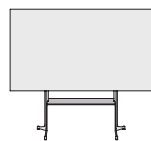

PENSATO PER L'INSTALLAZIONE DI MONITOR DI GRANDE FORMATO DAI 55" AGLI 85", IL CARTER POSTERIORE HA UN SISTEMA DI SGANCIAMENTO RAPIDO CHE PERMETTE DI NASCONDERE E ACCEDERE ALLE PRESE TV. IL PANNELLO TV NON RUOTA RISPETTO AL SUPPORTO, MA L'INSIEME PUÒ ESSERE FACILMENTE SPOSTATO GRAZIE AI SUPPORTI IN TEFLON. UN RIPIANO ACCESSORIO PUÒ ESSERE UTILIZZATO COME SUPPORTO DI SOUND-BAR O LETTORI MULTIMEDIALI.

Designed for the installation of large monitors (from 55" to 85"), the back cover has a rapid fit system that hides and allows access to the TV plugs. The TV panel does not rotate around the support but the whole unit can be moved easily thanks to the Teflon supports. An accessory shelf can be used for sound-bars or multimedia readers.

Conçu pour l'installation de télévisions grand format de 55 à 85 pouces, le panneau arrière dispose d'un système de décrochage rapide qui permet de dissimuler et d'accéder aux prises TV. Le panneau TV ne tourne pas par rapport au support, mais l'ensemble peut être facilement déplacé grâce aux supports en téflon. Une étagère pour accessoires peut être utilisée comme support pour les barres de son ou les lecteurs multimédias.

Gedacht für die Montage von großen Bildschirmen (von 55" bis 85"), hat das Gehäuse auf der Rückseite ein Schnellabhängsystem, wodurch die TV-Steckdosen versteckt werden und sie leicht erreicht werden können. Die TV-Platte dreht sich nicht unabhängig von der Unterlage, aber das Ganze kann dank der Teflon-Unterlagen leicht verstellt werden. Eine zusätzliche Ablage kann als Unterlage für Sound-Bar oder multimediale Player dienen.

Diseñada para la instalación de monitores de gran formato de 55" a 85", la cubierta trasera tiene un sistema de liberación rápida que permite ocultar y acceder a las tomas de TV. El panel del televisor no gira con respecto al soporte, pero el conjunto puede moverse fácilmente gracias a los soportes de teflón. Un estante accesorio puede utilizarse como soporte para barras de sonido o reproductores multimedia.



supporto monitor universale per TV da 55 a 85 pollici.  
universal monitor support for TV from 55 to 85 inches.  
support moniteur universel pour TV de 55 à 85 pouces.  
Universal-Monitor-Halter für TV von 55 bis 85 Zoll.  
soporte de monitor universal para TV de 55 a 85 pulgadas.

## FINITURE/FINISHES

verificare a listino dimensioni e finiture  
check dimensions and finishes in the price list

telaio / structure

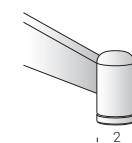

acciaio verniciato  
painted steel



C12  
bianco  
white



C21  
seta  
silk



C23  
corda  
ecru



C30  
ghisa  
cast-iron



C14  
antracite  
anthracite



C08  
nero  
black

## DIMENSIONI/DIMENSIONS

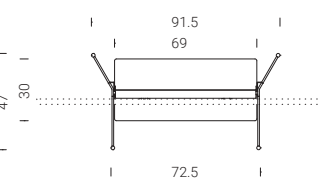
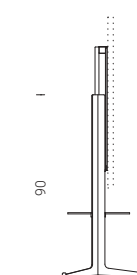
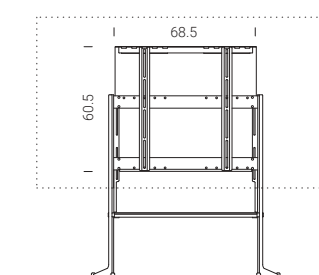
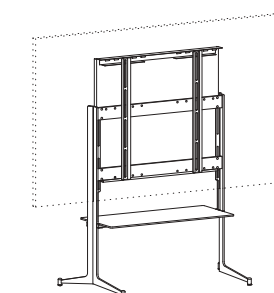
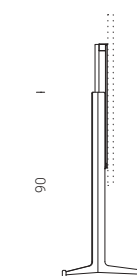
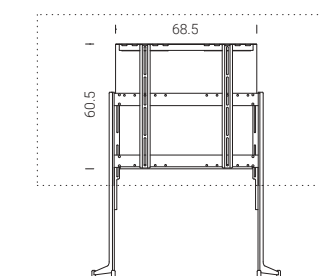
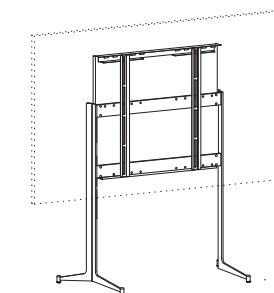

01/URANO

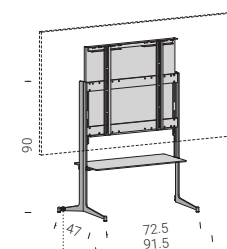

C08  
black



02/URANO

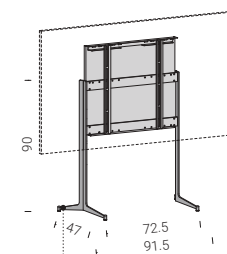

C08  
black



URANO

- › Caratteristiche funzionali
- › Functional characteristics
- › Caractéristiques fonctionnelles
- › Funktionale merkmale
- › Características funcionales

# WALK IN CLOSETS

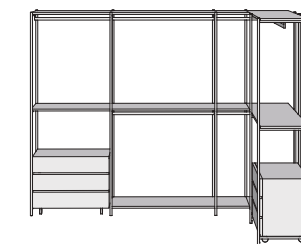

SLIDE

pg. 396

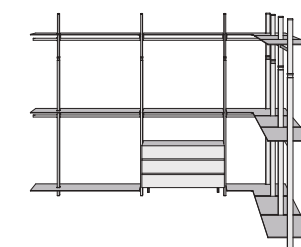

PERSONAL

pg. 412

# SLIDE

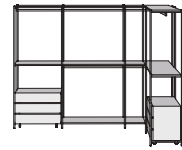

LE COPPIE DI PROFILI VERTICALI, I RIPIANI E LE BARRE APPENDERIA SONO ORDINABILI AL CENTIMETRO, CIÒ CONSENTE DI PROGETTARE LO SPAZIO DESIDERATO IN MODO SARTORIALE SENZA EXTRACOSTI DI RIDUZIONI.

The pairs of upright profiles, the shelves and hanging rails can be sized to the centimetre, making it possible to design a tailor-made space without the added cost of reductions.

Les paires de profils verticaux, les étagères et les barres porte-vêtements peuvent être commandées au centimètre, ceci permet d'organiser l'espace souhaité « sur mesure » sans coûts supplémentaires de réduction.

Die Paare vertikaler Profile, die Böden und die Aufhängestangen können zentimetergenau bestellt werden. Dadurch kann der gewünschte Raum ohne zusätzliche Kosten für Kürzungen maßgeschneidert geplant werden.

Los pares de perfiles verticales, estantes y barras de colgar se pueden pedir por centímetros, lo que permite diseñar el espacio deseado adaptándolos sin costos adicionales de reducción.

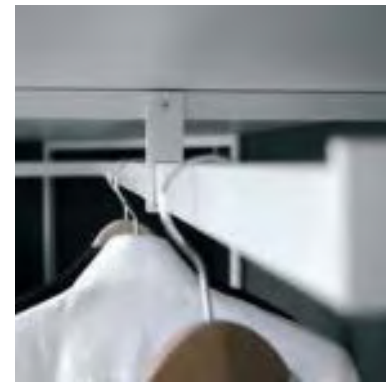
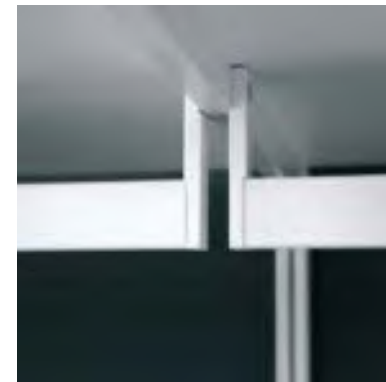
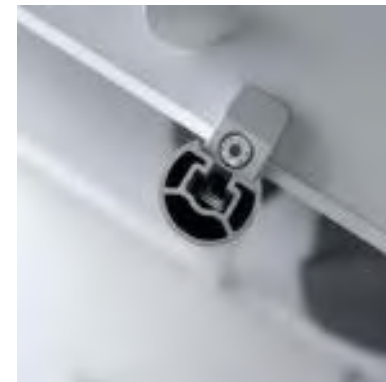

## PRODUCT CONCEPT

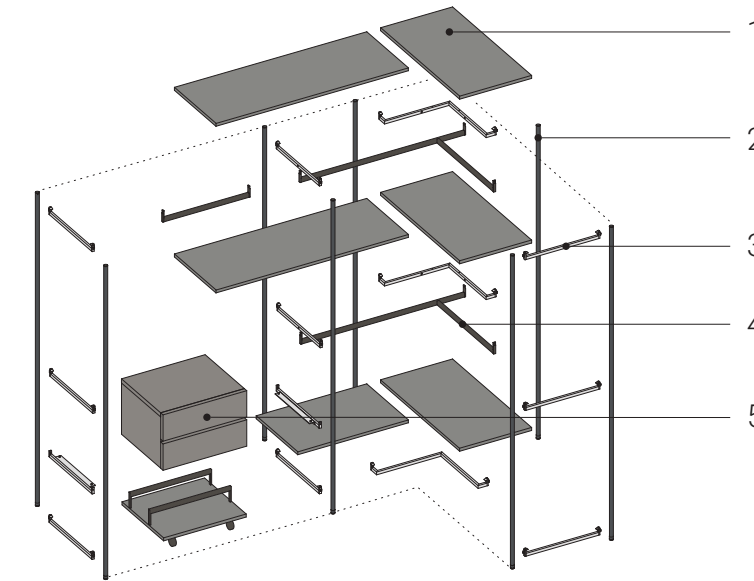

L  
61.5 - 91.5 - 121.5

H  
riducibile al centimetro  
reducible to the centimetre  
réductible au centimètre  
verkürzbar auf den Zentimeter  
reducible al centímetro

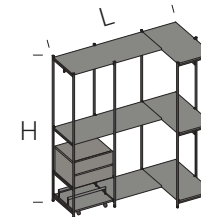

Ripiani e contenitori hanno libera posizione in altezza, (al centimetro).  
Shelves and containers can be positioned at any height (to the centimetre).  
Les étagères et les conteneurs peuvent être positionnés librement en hauteur (au centimètre près).  
Einlegeböden und Behälter sind in der Höhe frei einsetzbar (auf den Zentimeter).  
Los estantes y los contenedores tienen una posición de altura libre (al centimetro).

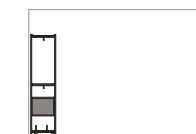

Pavimento / parete  
Floor / wall  
Sol / mur  
Boden / Wand  
Suelo / pared

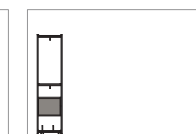

Pavimento / bifacciale  
Floor / Double-sided  
Sol / Double face  
Boden / Zweiseitig  
Suelo / Doble cara



Riduzioni a misura disponibili su profili verticali, ripiani e barre appendieria.  
Measurement reductions available on vertical profiles, shelves and hanging rails.  
Réductions sur mesure possibles sur les profilés verticaux, les étagères et les barres de penderie.  
Verkürzungen nach Kundenwunsch für vertikale Profile, Einlegeböden und Aufhängestangen verfügbar.  
Reducciones de tamaño disponibles en perfiles verticales, estantes y barras de colgar.



I ripiani sono continui e riducibili al centimetro, il sistema di ancoraggio a pinza tra ripiano e nodo consente il libero posizionamento in verticale ed orizzontale.

The shelves are continuous and reducible to a centimetre, the clamp anchoring system between the shelf and node allows free positioning both vertically and horizontally.

Les étagères sont continues et peuvent être réduites au centimètre près ; le système d'ancrage par pince entre l'étagère et le nœud permet un libre positionnement à la verticale ou à l'horizontale.

Die Einlegeböden sind durchlaufend und auf den Zentimeter verkürzbar, das Klemmen-Verankerungssystem zwischen Boden und Knotenpunkt ermöglicht die freie Positionierung, vertikal und horizontal.

Los estantes son continuos y pueden reducirse al centimetro. El sistema de sujeción entre el estante y el nodo permite un posicionamiento vertical y horizontal libre.



I nodi con funzione di supporto ed unione tra coppie di profili verticali e ripiani, sono in acciaio.

The nodes, that support and join couples of vertical profiles and shelves, are made of steel.

Les nœuds, avec fonction de support et d'union entre les paires de profilés verticaux et les étagères, sont en acier.

Die Knotenpunkte dienen als Stütze und Verbindung zwischen vertikalen Profilaaren und Einlegeböden und sind aus Stahl.

Los nudos que soportan y unen los pares de perfiles verticales y los estantes son de acero.



Le coppie di profili verticali sono in alluminio estruso con sezione circolare diametro 25 mm. La finitura viene eseguita con verniciatura a polveri a 180°.

The pairs of vertical profiles are made of extruded aluminium with circular section, diameter 25 mm. 180° powder coating finish.

Les paires de profilés verticaux sont en aluminium extrudé à section circulaire de 25 mm de diamètre. Les finitions sont réalisées avec peinture à poudre à 180°.

Die vertikalen Profilaare sind aus extrudiertem Aluminium mit kreisförmigem Querschnitt und einem Durchmesser von 25 mm. Die Beschichtung wird durch Pulverlackieren bei 180° ausgeführt.

Los pares de perfiles verticales son de aluminio extruido con un diámetro de sección circular de 25 mm. Están acabados con un revestimiento de polvo a 180°.



Le barre appendieria sono in alluminio verniciato a polveri a 180°. Esse sono indipendenti dai ripiani e sono ancorate al nodo in acciaio garantendo un'ottima resistenza ai carichi.

The hanging rails are in 180° powder coated aluminium. They are independent from the shelves and are anchored to the steel node, guaranteeing excellent resistance to loads.

Les barres de penderie sont en aluminium peint à la poudre à 180°. Elles sont indépendantes des étagères et ancrées au nœud en acier, permettant ainsi une excellente résistance aux charges.

Die Aufhängestangen sind aus 180°-pulverlackiertem Aluminium. Sie sind von den Böden unabhängig und sind mit dem Knotenpunkt aus Stahl verankert und gewährleisten so eine optimale Belastbarkeit.

Las barras de suspensión son de aluminio, con recubrimiento de polvo a 180°. Son independientes de las estanterías y se anclan al nudo de acero, garantizando una excelente resistencia a las cargas.



Le cassetiere a modulo 61.5/91.5/121.5 cm a 2/3/4/6 cassetti, sono disponibili in finitura melaminica e laccato. Sono disponibili in versione su ruote o sospese.

The 61.5/91.5/121.5 cm module chests of drawers with 2/3/4/6 drawers, are available in melamine and lacquered finish. They are available with wheels or in the suspended version.

Les blocs tiroirs 61,5/91,5/121,5 cm avec 2/3/4/6 tiroirs sont disponibles avec finitions en mélamine et laquées. Ils sont disponibles en versions à roulettes ou suspendues.

Die Modul-Schubladenschränke 61.5/91.5/121.5 cm mit 2/3/4/6 Schubladen sind mit den Beschichtungen Melamin und lackiert verfügbar. Sie sind in den Versionen auf Rädern oder aufgehängt verfügbar.

Las cajoneras modulares de 61.5/91.5/121.5 cm con 2/3/4/6 cajones están disponibles en acabado melamina y lacado. Están disponibles en versión con ruedas o suspendidas.

## FINITURE/FINISHES

### spalle / support profiles

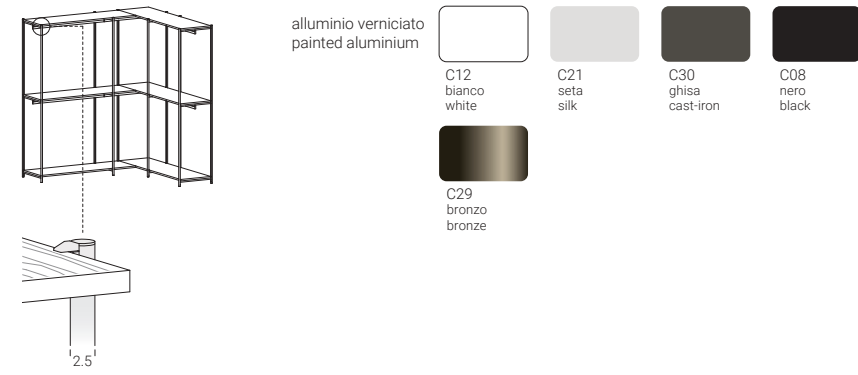

## DIMENSIONI/DIMENSIONS

verificare a listino dimensioni e finiture  
check dimensions and finishes in the price list

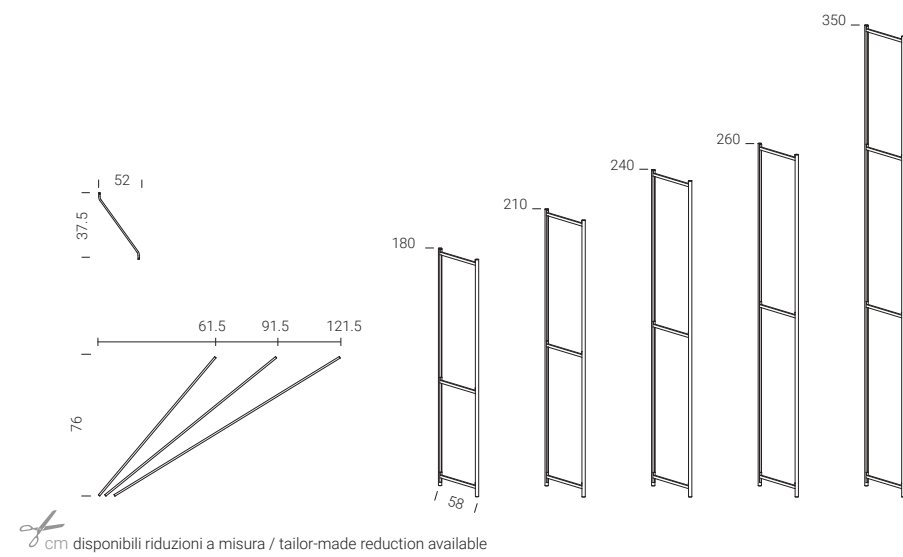

## FINITURE/FINISHES

### contenitori / cabinets

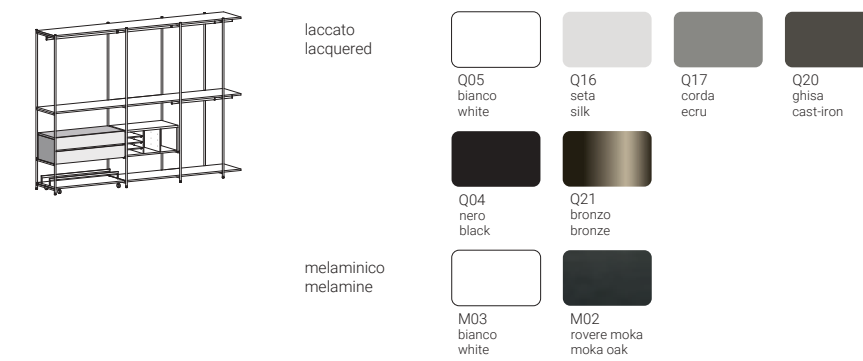

## DIMENSIONI/DIMENSIONS

verificare a listino dimensioni e finiture  
check dimensions and finishes in the price list

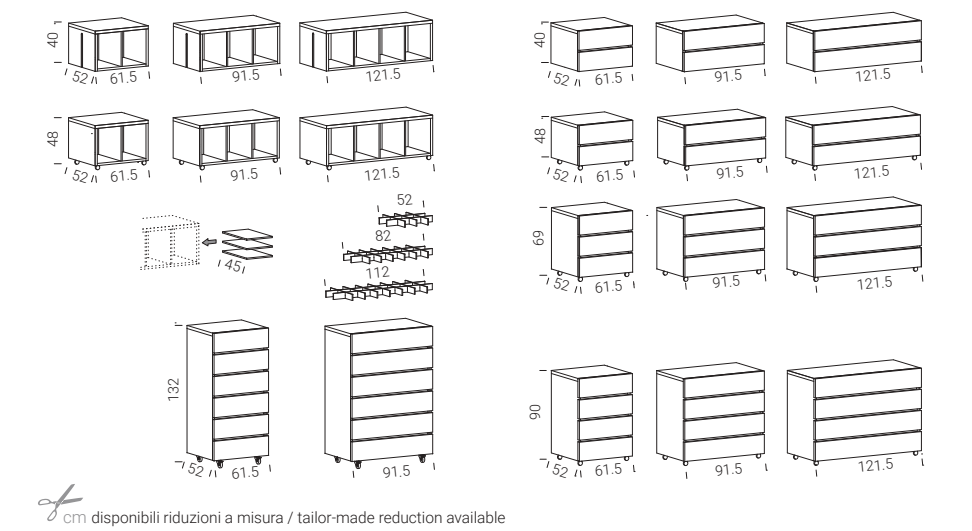

### ripiani in agglomerato ligneo / wood composite shelves

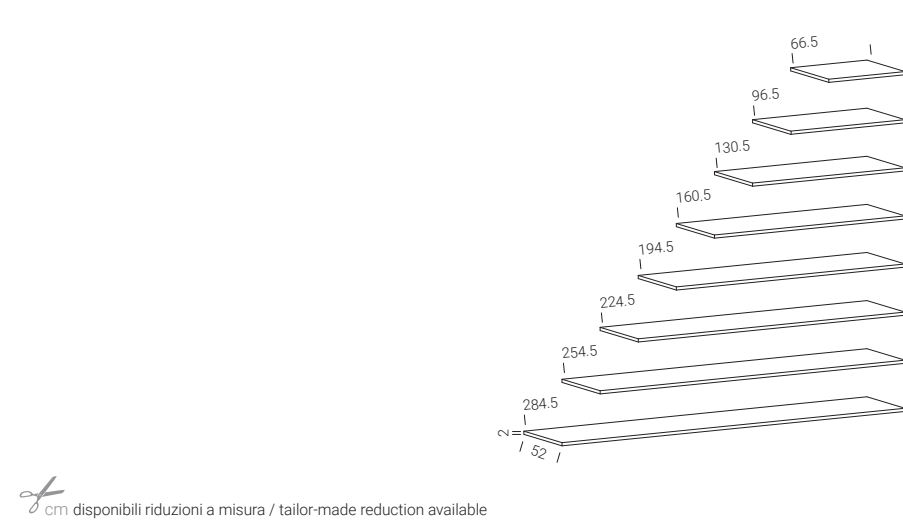
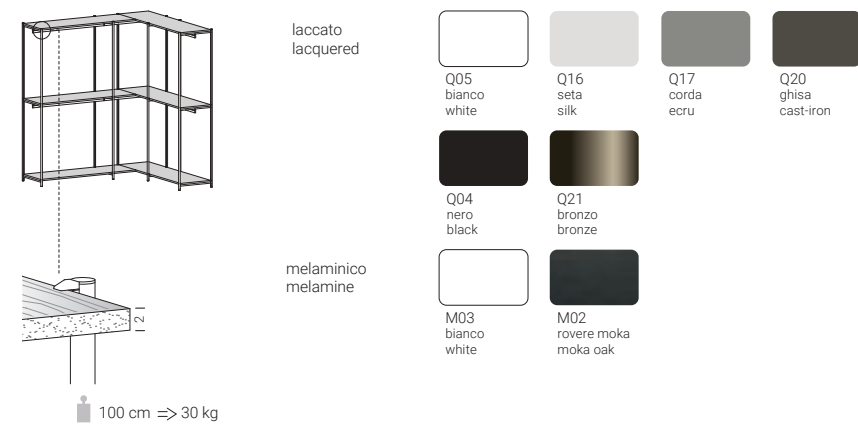

### ripiani portascarpe su ruote / shoe rack shelves on casters

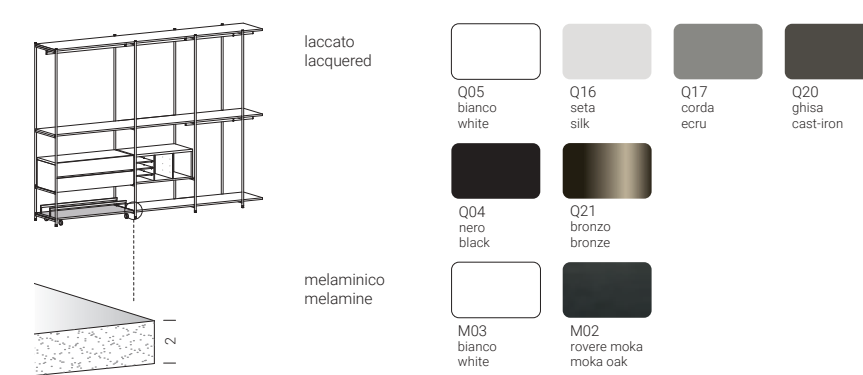

### barre portabiti / clothes rails

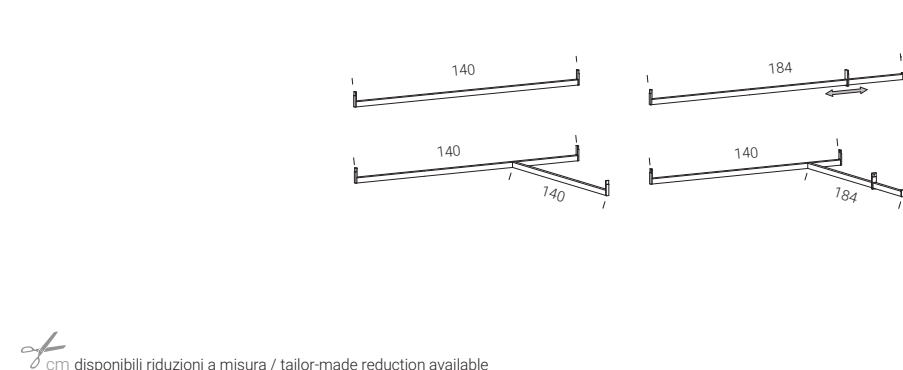

### portapantaloni / trouser rail





01/SLIDE

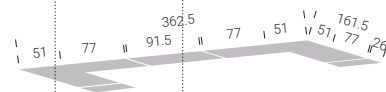
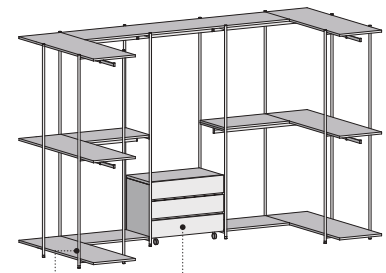

C08  
black

M02  
moka oak





04/SLIDE

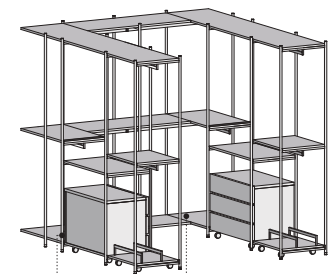

C12  
white

M03  
white





03/SLIDE

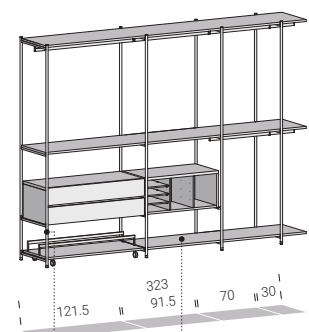

C21  
silk

Q17  
ecru



02/SLIDE

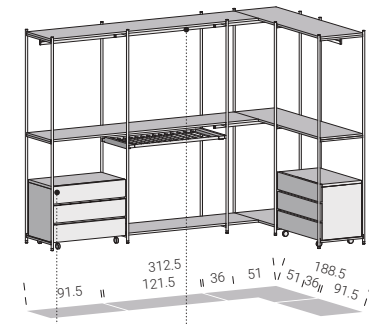

M03  
white

C12  
white



# PERSONAL

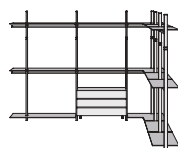

IL SISTEMA BREVETTATO EXTENDO È FORMATO DA DUE PROFILI IN ALLUMINIO ESTENSIBILI, ADATTABILI ALLE DIVERSE ALTEZZE DEGLI AMBIENTI. AGENDO SULLA LEVA A SCOMPARSA, I PROFILI SI BLOCCANO ALL'ALTEZZA DESIDERATA E SI COMPRIMONO TRA PAVIMENTO E SOFFITTO, SENZA L'UTILIZZO DI ALCUN UTENSILE O PRE-FISSAGGIO.

The patented extendo system consists of two extendable aluminium profiles that can be adapted to environments of various heights. Using the foldaway lever, the profiles can be blocked at the desired height and compressed between floor and ceiling, without having to use any kind of pre-fixing tool.

Le système breveté extendo est constitué de deux profils extensibles en aluminium pouvant être adaptés aux différentes hauteurs des milieux. En agissant sur le levier escamotable, les profils se verrouillent à la hauteur souhaitée et se compriment entre plancher et plafond, sans utiliser aucun outil ou préfixation.

Das patentierte System extendo besteht aus zwei ausziehbaren Aluminium-Profilen, die an unterschiedliche Raumhöhen angepasst werden können. Durch einen versenkbaren Hebel werden die Profile auf der gewünschten Höhe blockiert und zwischen Fußboden und Zimmerdecke ohne Werkzeug oder Vor-Befestigung komprimiert eingesetzt.

El sistema patentado extendo está formado por dos perfiles de aluminio extensibles, adaptables a las distintas alturas de los ambientes. Actuando sobre la palanca escondida, los perfiles se bloquean a la altura deseada y se comprimen entre el suelo y el techo, sin que sea necesario utilizar ninguna herramienta o fijación previa.



## PRODUCT CONCEPT

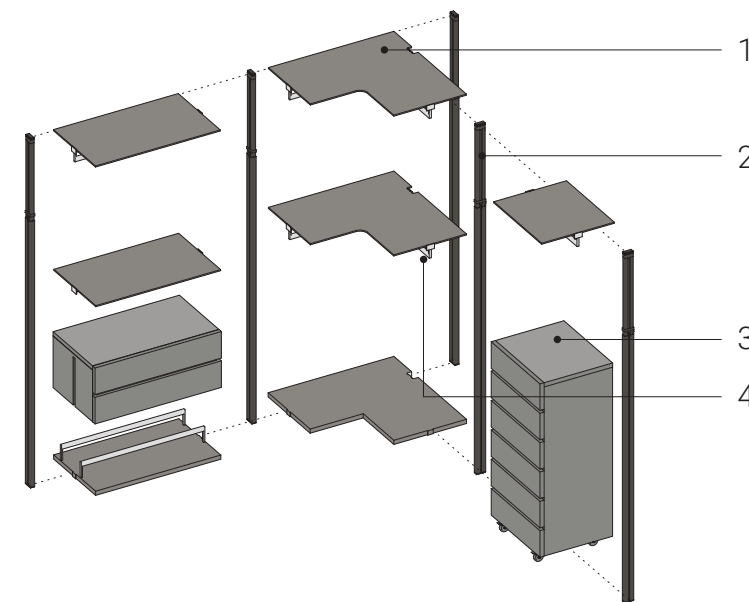

L  
60 - 90 - 120  
H  
210 / 400

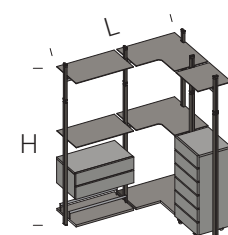

Ripiani e contenitori hanno libera posizione in altezza, (al centimetro).  
Shelves and containers can be positioned at any height (to the centimetre).  
Les étagères et les conteneurs peuvent être positionnés librement en hauteur (au centimètre près).  
Einlegeböden und Behälter sind in der Höhe frei einsetzbar (auf den Zentimeter).  
Los estantes y contenedores tienen una altura libre (al centimetro).

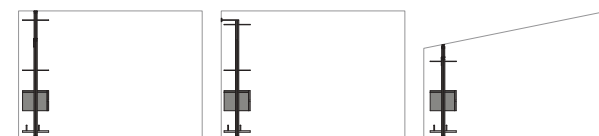

Pavimento / soffitto  
Floor / ceiling  
Sol / plafond  
Boden / Decke  
Suelo / techo

Pavimento / parete  
Floor / wall  
Sol / mur  
Boden / Wand  
Suelo / pared

Soffitto inclinato  
Sloping ceiling  
Plafond incliné  
Schräge Decke  
Techo inclinado



I ripiani a modulo 60/90/120 cm. ed angolari sono disponibili in finitura melaminico, laccato e vetro. In tutte le finiture è prevista la riduzione a misura.

The 60/90/120 cm shelves and corner pieces are available in melamine, lacquered and glass finish. Measurement reduction is available for all the finishes.

Les étagères du module 60/90/120 cm et les pièces d'angle sont disponibles dans les finitions en mélamine, laquées et en verre. Une réduction de taille est possible dans toutes les finitions.

Die Modul-Einlegeböden 60/90/120 cm und die Eckmodule sind mit den Beschichtungen Melamin, lackiert und Glas verfügbar. In allen Beschichtungen ist die Verkürzung nach Kundenwunsch möglich.

Los estantes modulares y de esquina de 60/90/120 cm están disponibles en acabados de melamina, lacado y cristal. La reducción de tamaño es posible en todos los acabados.



Le cassettiere a modulo 60/90/120 cm a 2/3/4/6 cassetti, sono disponibili in finitura melaminico e laccato. Sono disponibili in versione su ruote o sospese.

The 60/90/120 cm module chests of drawers with 2/3/4/6 drawers, are available in melamine and lacquered finish. They are available with wheels or in the suspended version.

Les blocs tiroirs 60/90/120 cm avec 2/3/4/6 tiroirs sont disponibles avec finitions en mélamine et laquées. Ils sont disponibles en versions à roulettes ou suspendues.

Die Modul-Schubladenschränke 60/90/120 cm mit 2/3/4/6 Schubladen sind mit den Beschichtungen Melamin und lackiert verfügbar. Sie sind in den Versionen auf Rädern oder aufgehängt verfügbar.

Las cajoneras modulares de 60/90/120 cm con 2/3/4/6 cajones están disponibles en acabado melamina y lacado. Están disponibles en versión con ruedas o suspendidas.



I profili in alluminio estruso, sono configurabili per adattarsi alle diverse esigenze degli ambienti. Sono infatti possibili configurazioni per installazioni a soffitto, parete e soffitto inclinato.

The extruded aluminium profiles are modular, to adapt to the needs of the spaces. Indeed, configurations are available for ceiling, wall and sloping ceiling mounting.

Les profilés en aluminium extrudé peuvent être configurés pour s'adapter aux différents besoins des espaces. En effet, des configurations pour des installations au plafond, murales et sur plafond incliné sont possibles.

Die Profile aus extrudiertem Aluminium sind gestaltbar, um sich an die verschiedenen Anforderungen der Räume anzupassen. Es sind nämlich Konfigurationen für die Montage an der Decke, an der Wand und an schräger Decke möglich.

Los perfiles de aluminio extruido pueden configurarse para adaptarse a los distintos requisitos del entorno. Las configuraciones son posibles para instalaciones en el techo, en la pared y en el techo inclinado.



Le barre appenderia sono in alluminio verniciato a polveri a 180°. Esse si possono installare sotto il ripiano o direttamente tra i due profili verticali.

The hanging rails are in 180° powder coated aluminium. These can be installed below the shelf or directly between the two vertical profiles.

Les barres de penderie sont en aluminium peint à la poudre à 180°. Elles peuvent être installées sous l'étagère ou directement entre les deux profils verticaux.

Die Aufhängestangen sind aus 180°-pulverlackiertem Aluminium. Sie können unter dem Einlegeboden oder direkt zwischen den zwei vertikalen Profilen montiert werden.

Las barras de suspensión son de aluminio con recubrimiento de polvo a 180°. Pueden instalarse bajo la estantería o directamente entre los dos perfiles verticales.



Riduzioni a misura disponibili su profili verticali, ripiani e barre appenderia.  
Measurement reductions available on vertical profiles, shelves and hanging rails.  
Réductions sur mesure possibles sur les profils verticaux, les étagères et les barres de penderie.  
Verkürzungen nach Kundenwunsch für vertikale Profile, Einlegeböden und Aufhängestangen verfügbar.  
Reducciones de tamaño disponibles en perfiles verticales, estantes y barras de colgar.

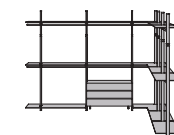

Profilo telescopico brevettato  
Patented telescopic profile  
Profilé télescopique breveté  
Patentiertes teleskopisches Profil  
Perfil telescópico patentado

## FINITURE/FINISHES

### profilo extendo / extendo profile



## DIMENSIONI/DIMENSIONS

verificare a listino dimensioni e finiture  
check dimensions and finishes in the price list

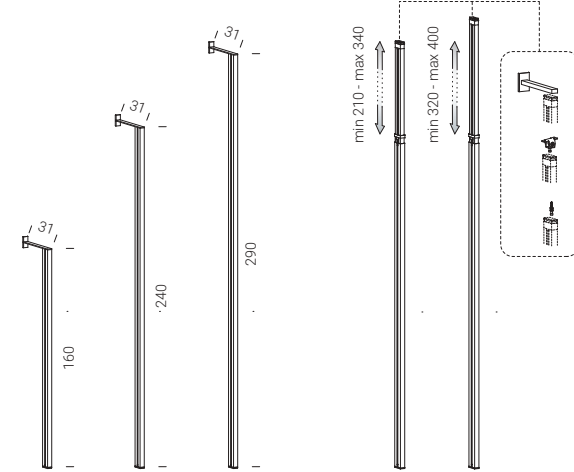

cm disponibili riduzioni a misura / tailor-made reduction available

### ripiani in agglomerato ligneo / wood composite shelves

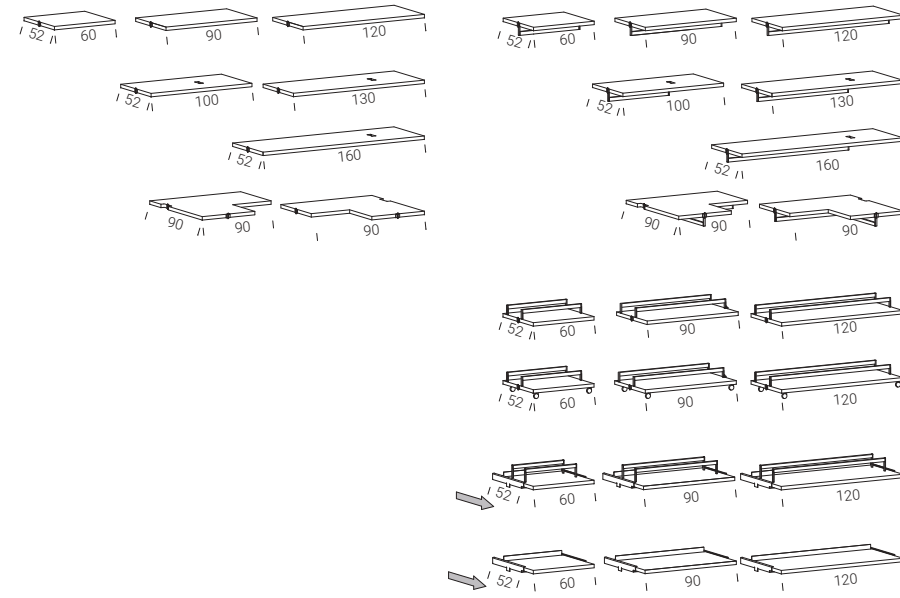
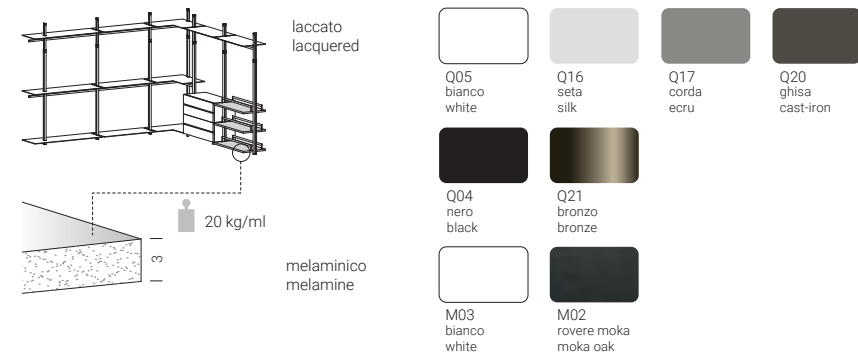

cm disponibili riduzioni a misura / tailor-made reduction available

## FINITURE/FINISHES

### ripiani in vetro / glass shelves

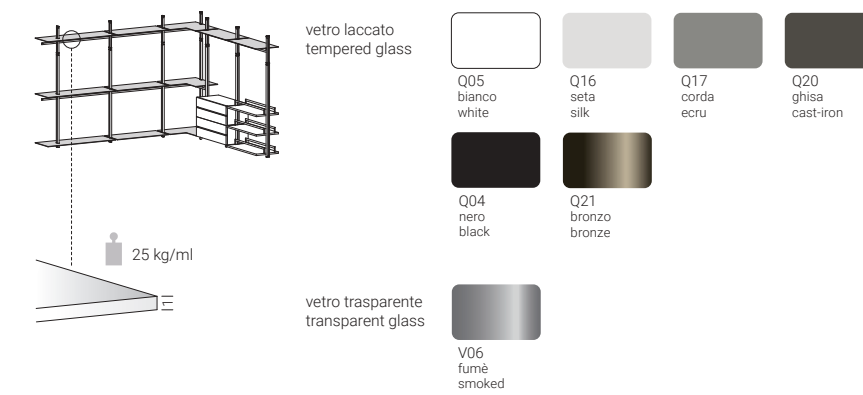

### contenitori / cabinets

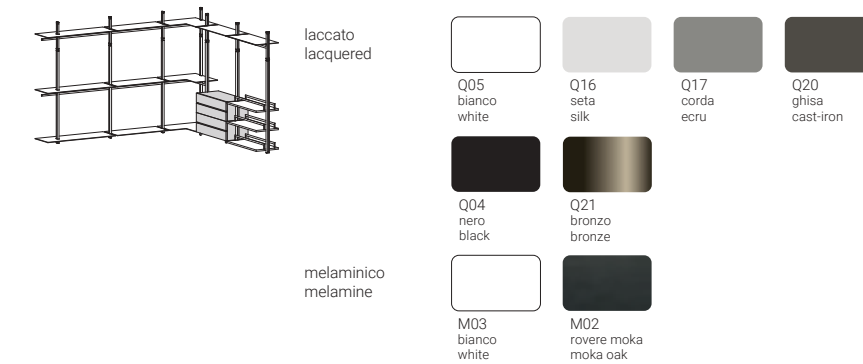

## DIMENSIONI/DIMENSIONS

verificare a listino dimensioni e finiture  
check dimensions and finishes in the price list

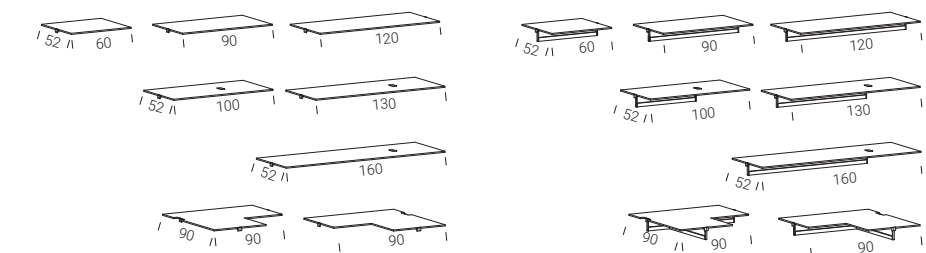

cm disponibili riduzioni a misura / tailor-made reduction available

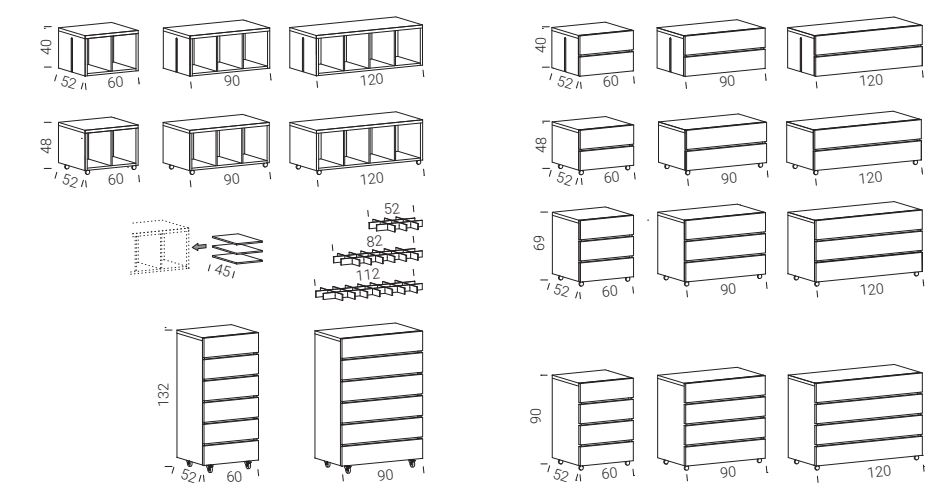

### accessori / accessories

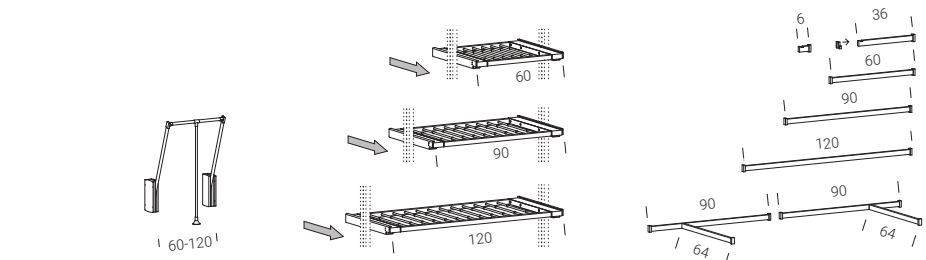
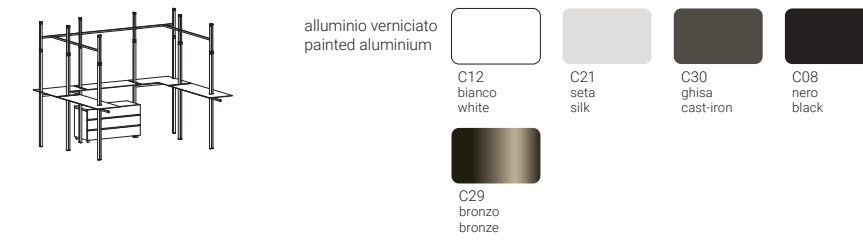



01/PERSONAL

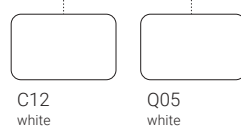
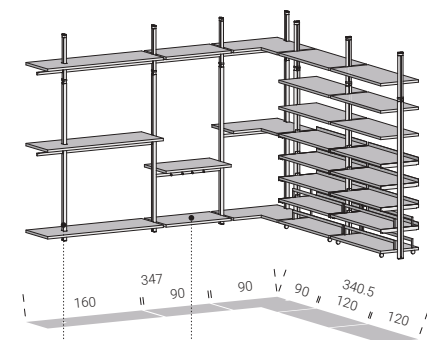

PERSONAL

- Sistema brevettato
- Patented system
- Système breveté
- Patentiertes system
- Sistema patentado



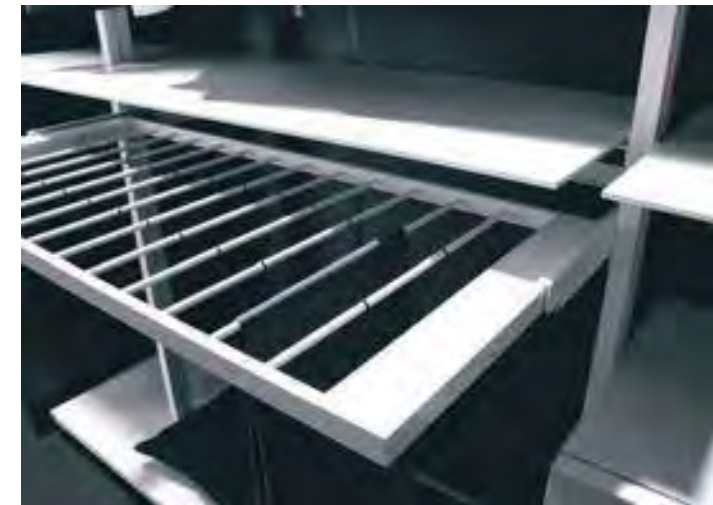

02/PERSONAL

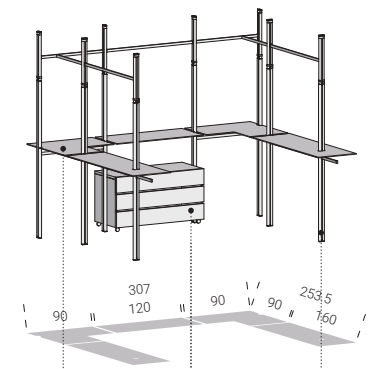

- V06 smoked glass
- Q04 black
- C08 black



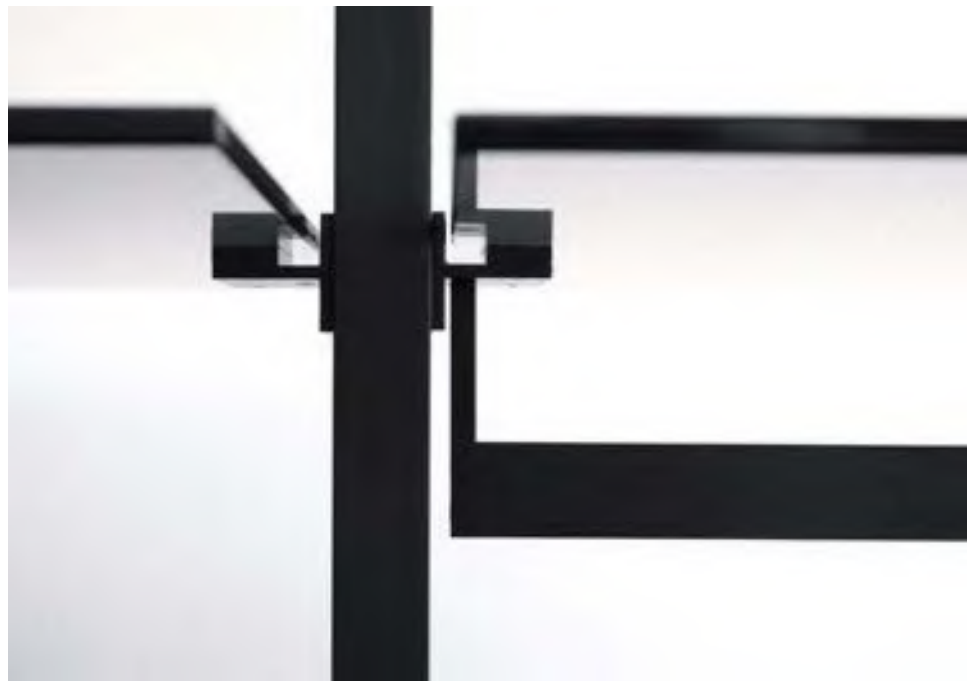

03/PERSONAL

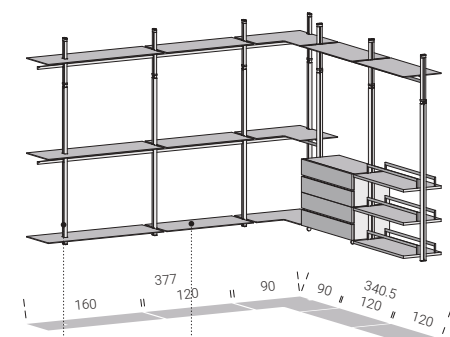

C12  
white

Q05  
white





04/PERSONAL

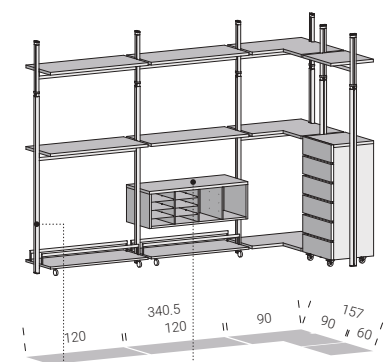

C21  
silk

Q17  
ecru



05/PERSONAL

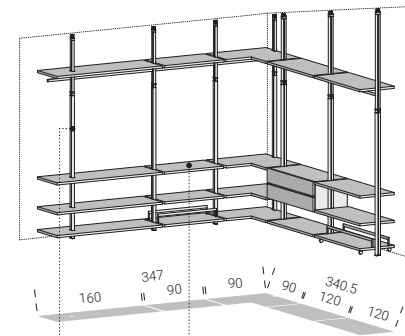

C12  
white

Q05  
white





**art direction**  
extendo design dept.

**photo post-production**  
extendo design dept.  
marigraf.it

**graphic layout**  
marigraf.it



via Del Lavoro 2  
35010 Trebaseleghe PD - Italy

tel. +39 049 938 7633  
info@extendoweb.com  
www.extendoweb.com



extendo ©  
ESTV0095

