

Collection Book /2

Frag
dal 1921

Collection Book /2

Product Index (A–Z)

240	Aileron	206	Iki
284	Argor	228	Kati
024	Arita	288	Latina
068	Artù	310	Lilly
200	Atelier	314	Linda
148	Bak	260	Lyo
184	Bella	308	Maio
234	Bridge	264	Mea
318	Canouan	092	Morgans
218	Caribou	108	Motif
134	Clubby	252	Nisida
124	Cocoon	096	Olimpia
246	Comb	100	Otis
274	Dante	038	Otto
304	Darling	018	Paipu
112	Dindi	194	Ponza
120	Doa	210	Privé
298	Doni	114	Public
280	Ele	088	Riviera
050	Elf	142	Sahrai
270	Fizzy	084	Sofy
042	Gast	164	Square
294	Heta	256	Twain
224	Hollow	128	Viae
178	Hudson	076	Wilton
		058	Winnie

Table of contents

I. 005 — 015 Abacus	II. 017 — 047 New Products	III. 048 — 049 Company Reportage
IV. 049 — 319 The Collection	V. 320 — 321 Materials Mood	VI. 321 — 337 Contract Inspirations
	VII. 339 — 365 Technical Details	

Abacus (A—Z)



Chairs & Armchairs



Aileron
FG 334.00
Shooting p. 240 - 245
Details p. 340



Bella
FG 320.01
Shooting p. 184 - 193
Details p. 340 - 341



Bella P
FG 320.03
Shooting p. 184 - 193
Details p. 340 - 341



Elf P
FG 497.01
Shooting p. 050 - 057
Details p. 343



Elf H
FG 497.02
Shooting p. 050 - 057
Details p. 343
Also p. 72 - 73



Elf HP
FG 497.03
Shooting p. 050 - 057
Details p. 343



Iki W
FG 333.05
Shooting p. 206 - 209
Details p. 344 Also p. 150,
152 - 153, 284



Bella H
FG 320.00
Shooting p. 184 - 193
Details p. 340 - 341
Also p. 298, 331, 332



Bella HP
FG 320.02
Shooting p. 184 - 193
Details p. 340 - 341
Also p. 331



Bella H GM
FG 320.06
Shooting p. 184 - 193
Details p. 340 - 341



Bella HP GM
FG 320.08
Shooting p. 184 - 193
Details p. 340 - 341



Iki PW
FG 333.06
Shooting p. 206 - 209
Details p. 344 Also p. 150,
152 - 153, 274, 276 - 277, 284



Kati
FG 414.00
Shooting p. 228 - 233
Details p. 345



Kati P
FG 415.00
Shooting p. 228 - 233
Details p. 345



Kati Q
FG 414.04
Shooting p. 228 - 233
Details p. 345



Bella HW
FG 320.10
Shooting p. 184 - 193
Details p. 340 - 341



Bella HP W
FG 320.12
Shooting p. 184 - 193
Details p. 340 - 341



Darling 4
FG 356.04
Shooting p. 304 - 307
Details p. 342



Dindi
FG 448.00
Shooting p. 112 - 113
Details p. 342



Kati PQ
FG 415.04
Shooting p. 228 - 233
Details p. 345



Kati Z
FG 414.02
Shooting p. 228 - 233
Details p. 345



Kati PZ
FG 415.02
Shooting p. 228 - 233
Details p. 345



Latina
FG 260.00
Shooting p. 288 - 293
Details p. 345 - 346
Also p. 200



Doa
FG 464.03
Shooting p. 120 - 123
Details p. 342



Doa P
FG 464.02
Shooting p. 120 - 123
Details p. 342



Ele
FG 457.00
Shooting p. 280 - 283
Details p. 343



Elf
FG 497.00
Shooting p. 050 - 057
Details p. 343



Latina P
FG 262.01
Shooting p. 288 - 293
Details p. 345 - 346



Latina H
FG 261.00
Shooting p. 288 - 293
Details p. 345 - 346



Latina HP
FG 262.00
Shooting p. 288 - 293
Details p. 345 - 346



Lilly
FG 408.00
Shooting p. 310 - 313
Details p. 346
Also p. 202 - 203



Lilly H
FG 408.01
Shooting p. 310 - 313
Details p. 346



Linda
FG 413.00
Shooting p. 314 - 317
Details p. 347



Lyo
FG 352.00
Shooting p. 260 - 263
Details p. 347
Also p. 218, 220, 221



Mea C
FG 462.05
Shooting p. 264 - 269
Details p. 347



Mea AR
FG 462.00
Shooting p. 264 - 269
Details p. 347



Mea H AR
FG 461.00
Shooting p. 264 - 269
Details p. 347



Bella CP
FG 320.14
Shooting p. 184 - 193
Details p. 340 - 341

Stools
→



Mea HC
FG 461.05
Shooting p. 264 - 269
Details p. 347



Nisida
FG 342.00
Shooting p. 252 - 255
Details p. 348
Also p. 234, 236 - 237, 287



Nisida P
FG 342.01
Shooting p. 252 - 255
Details p. 348
Also p. 324, 287



Olimpia
FG 501.00
Shooting p. 096 - 099
Details p. 348



Bella GP
FG 320.04
Shooting p. 184 - 193
Details p. 340 - 341



Elf C
FG 497.10
Shooting p. 50 - 57
Details p. 343



Elf B
FG 497.11
Shooting p. 50 - 57
Details p. 343
Also 303



Elf GP
FG 497.12
Shooting p. 50 - 57
Details p. 343



Olimpia P
FG 501.01
Shooting p. 096 - 099
Details p. 348
Also p. 095



Ponza
FG 405.00
Shooting p. 194 - 199
Details p. 348
Also p. 322



Public
FG 506.00
Shooting p. 114 - 119
Details p. 349
Also p. 022



Public P
FG 506.01
Shooting p. 114 - 119
Details p. 349



Fizzy
FG 458.00
Shooting p. 270 - 273
Details p. 343 - 344



Fizzy
FG 458.01
Shooting p. 270 - 273
Details p. 343 - 344



Latina GP
FG 265.00
Shooting p. 288 - 293
Details p. 345 - 346



Latina CP
FG 265.04
Shooting p. 288 - 293
Details p. 345 - 346



Sofy
FG 446.00
Shooting p. 84 - 87
Details p. 349
Also p. 328



Square
FG 465.00/465.20
Shooting p. 164 - 177
Details p. 350
Also p. 336 - 337

Chairs
with
Casters
→



Canouan D
FG 282.03
Shooting p. 318 - 319
Details p. 341



Lilly B
FG 408.03
Shooting p. 310 - 313
Details p. 346



Lilly C
FG 408.02
Shooting p. 310 - 313
Details p. 346



Lilly GP
FG 408.04
Shooting p. 310 - 313
Details p. 346



Ponza GP
FG 405.07
Shooting p. 194 - 199
Details p. 348
Also p. 326 - 327



Square B
FG 465.03/465.23
Shooting p. 164 - 177
Details p. 350



Square C
FG 465.02/465.22
Shooting p. 164 - 177
Details p. 350

Lounge
Chairs
→



Aileron L
FG 334.01
Shooting p. 240 - 245
Details p. 340

Poufs
→



Clubby Pouf
FG 493.10
Shooting p. 134 - 141
Details p. 341
Also p. 126 - 127



Cocoon Pouf
FG 495.01
Shooting p. 124 - 127
Details p. 342
Also p. 106 - 107



Heta Pouf
FG 426.01
Shooting p. 294 - 297
Details p. 344



Bella L
FG 320.05
Shooting p. 184 - 193
Details p. 340 - 341



Clubby
FG 493.00/493.20/493.30
Shooting p. 134 - 141
Details p. 341



Cocoon
FG 495.00
Shooting p. 124 - 127
Details p. 342
Also p. 106 - 107



Heta
FG 426.00
Shooting p. 294 - 297
Details p. 344



Maio
FG 421.00
Shooting p. 308 - 309
Details p. 347 / Also p.
158, 214 - 215, 248 - 249



Sahrai Pouf
FG 471.01
Shooting p. 142 - 147
Details p. 349
Also p. 334 - 335

Sofas
→



Gast 210 FG 521.00
Gast 240 FG 521.01
Shooting p. 042 - 047
Details p. 353
Also p. 034



Hollow
FG 482.00/482.01
Shooting p. 224 - 227
Details p. 344
Also 78 - 79



Latina L
FG 285.00
Shooting p. 288 - 293
Details p. 345 - 346



Public L
FG 506.02
Shooting p. 114 - 119
Details p. 349
Also p. 102 - 103, 175



Riviera
FG 499.00
Shooting p. 88 - 91
Details p. 349
Also p. 108



Hudson Day Bed
FG 477.00
Shooting p. 178 - 183
Details p. 353



Otis
FG 510
Shooting p. 100 - 107
Details p. 354



Public TS
FG 506.03
Shooting p. 114 - 119
Details p. 355

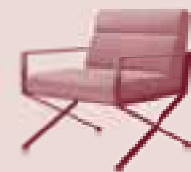

Sharai L
FG 471.00
Shooting p. 142 - 147
Details p. 349
Also p. 334 - 335



Square L
FG 465.01/465.21
Shooting p. 164 - 177
Details p. 350



Winnie
FG 483.00
Shooting p. 58 - 67
Details p. 350



Wilton
FG 511
Shooting p. 76 - 83
Details p. 356 - 357



Winnie 200 FG 483.01
Winnie 240 FG 483.02
Shooting p. 58 - 67
Details p. 355

Desks
→



Arita Desk
FG 520.01
Shooting p. 024 - 037
Details p. 358



Arita Console
FG 520.02
Shooting p. 024 - 037
Details p. 358



Dante 120 FG 366.01
Dante 150 FG 366.00
Dante 180 FG 366.02
Shooting p. 274 - 279
Details p. 361



Doni 73
FG 485.00
Shooting p. 298 - 303
Details p. 361
Also p. 332



Doni 110
FG 485.02
Shooting p. 298 - 303
Details p. 361
Also p. 056



Doni 62
FG 485.01
Shooting p. 298 - 303
Details p. 361
Also p. 66 - 67, 138 - 139



Paipu 140 FG 522.01
Paipu 160 FG 522.00
Paipu 180 FG 522.02
Shooting p. 018 - 023
Details p. 362



Twain
FG 444.00
Shooting p. 256 - 259
Details p. 363
Also p. 095

Tables
→



Argor 140 FG 404.00
Argor 160 FG 404.03
Shooting p. 284 - 287
Details p. 358
Also p. 252



Artù 160 FG 494.00
Artù 180 FG 494.01
Artù 200 FG 494.02
Shooting p. 068 - 075
Details 358 - 359 / Also p. 116



Paipu 240 FG 522.11
Paipu 260 FG 522.10
Shooting p. 018 - 023
Details p. 362

Occasional
Tables
→



Arita CT
FG 520.00
Shooting p. 024 - 037
Details p. 351
Also p. 047



Bak CT
FG 442.01
Shooting p. 148 - 163
Details p. 351



Atelier 140
FG 468.50
Shooting p. 200 - 205
Details p. 359



Atelier 240 FG 468.00
Atelier 300 FG 468.01
Shooting p. 200 - 205
Details p. 359

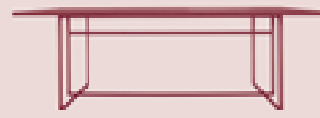

Bak Table
FG 442.00
Shooting p. 148 - 163
Details p. 359
Also p. 116, 166, 184



Bak CT H
FG 442.02
Shooting p. 148 - 163
Details p. 351



Bak CT O
FG 442.03
Shooting p. 148 - 163
Details p. 351



Bak CT HO
FG 442.04
Shooting p. 148 - 163
Details p. 351



Comb 100
FG 487.01
Shooting p. 246 - 251
Details p. 351
Also p. 058, 060 - 061

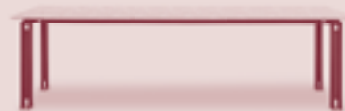

Bridge 210 FG 453.01, **Bridge 240**
FG 453.00, **Bridge 270** FG 453.02
Bridge 300 FG 453.03
Shooting p. 234 - 239
Details p. 360 / Also p. 264



Caribou 240
FG 480.01
Shooting p. 218 - 223
Details p. 360



Dante 180
FG 366.02
Shooting p. 274 - 279
Details p. 361



Comb 40
FG 487.02
Shooting p. 246 - 251
Details p. 351
Also p. 106 - 107



Motif 35
FG 509.02
Shooting p. 108 - 111
Details p. 352
Also p. 040, 076, 081



Motif 55
FG 509.00
Shooting p. 108 - 111
Details p. 352



Motif 100
FG 509.01
Shooting p. 108 - 111
Details p. 352
Also p. 081



Sahrai CT
FG 471.02
Shooting p. 142 - 147
Details p. 352
Also p. 334 - 335



Square 34/24
FG 465.60
Shooting p. 164 - 177
Details p. 352 - 353
Also p. 114, 175



Square 52/42
FG 465.61
Shooting p. 164 - 177
Details p. 352 - 353 /
Also p. 078, 180, 083, 178

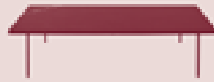

Square 140
FG 465.56
Shooting p. 164 - 177
Details p. 352 - 353
Also p. 082, 078, 175



Privé B
FG 478.00
Shooting p. 210 - 217
Details p. 364



Privé C
FG 478.01
Shooting p. 210 - 217
Details p. 364
Also p. 078 - 079



Viae Valet Stand
FG 484.50
Shooting p. 128 - 133
Details p. 365



Square 100
FG 465.54
Shooting p. 164 - 177
Details p. 352 - 353
Also p. 082 - 083, 102 - 103



Viae 3
FG 484.01
Shooting p. 128 - 133
Details p. 353



Viae 5
FG 484.00
Shooting p. 128 - 133
Details p. 353

Complements
→



Bak Valet Stand
FG 440.00
Shooting p. 148 - 163
Details p. 363



Bak Valet Stand Mirror
FG 440.01
Shooting p. 148 - 163
Details p. 363



Bak Bookcase
FG 440.10
Shooting p. 148 - 163
Details p. 363
Also p. 116



Bak Bench
FG 441.01
Shooting p. 148 - 163
Details p. 363



Morgans
FG 507.00
Shooting p. 092 - 095
Details p. 364
Also p. 081, 106 - 107



Otto Queen FG 517.00,
Otto King FG 517.01,
Otto 180 FG 517.05,
Otto 160 FG 517.04
Shooting p. 038 - 041
Details p. 364 - 365



Privé A
FG 478.10
Shooting p. 210 - 217
Details p. 364
Also p. 082 - 083

New Products:



Paipu,



(It) tavolo da pranzo disponibile in due varianti, tondo ed ovale, dall'evocativo sapore che richiama i diktat dell'architettura high-tech anni '70, dove tutti gli elementi impiantistici e strutturali venivano trasferiti sulle facciate e lasciati interamente a vista. I tubolari in acciaio curvato che compongono la base, regalano movimento e rigore al progetto, dialogando in armonico contrasto con la ricchezza del prezioso piano in marmo. Nella sua versione tonda il tavolo è sorretto da singola base con tubolari disposti a croce, mentre la versione ovale è sorretta da una doppia base con tubolari disposti a "t".

(En) *dining table available in two versions, round and oval, with an evocative taste that recalls the diktats of the high-tech architecture of the 70s, when all the system and structural elements were transferred to the facades and left entirely exposed. The curved steel tubes that make up the base confer movement and rigour to the project, in a dialogue of harmonic contrast with the richness of the precious marble top. In the round version the table is supported by a single base with tubes arranged in a cross, while the oval version is supported by a double base with tubes arranged in a "t" shape.*



→ Paipu 160 / FG 522.00
→ Paipu 260 / FG 522.10



→ Paipu 260 / FG 522.10
→ Public / FG 506.00



Arita Family,

(It) collezione di tre elementi composta da scrittoio, consolle e tavolino, dal design minimale e al contempo ricca di dettagli. Il disegno pulito ed essenziale del sottile piano d'appoggio acquisisce ritmo nella sua forma insolita e inaspettata. La mancanza di simmetria sia nel piano che nelle gambe, i volumi sottratti negli angoli e la struttura di sostegno sporgente, fanno di Arita una collezione unica nel suo genere e perfetta per una ricercata progettazione d'interni.

(En) *collection of three elements composed of a desk, a console and a coffee table, with a minimalist design yet rich in detail. The clean and essential design of the thin table top acquires rhythm through its unusual and unexpected shape. The lack of symmetry in both the top and the legs, the subtracted volumes in the corners and the protruding supporting structure, make Arita a unique collection in its kind and perfect for a refined interior design project.*

Arita Desk,



→ Arita Desk / FG 520.01

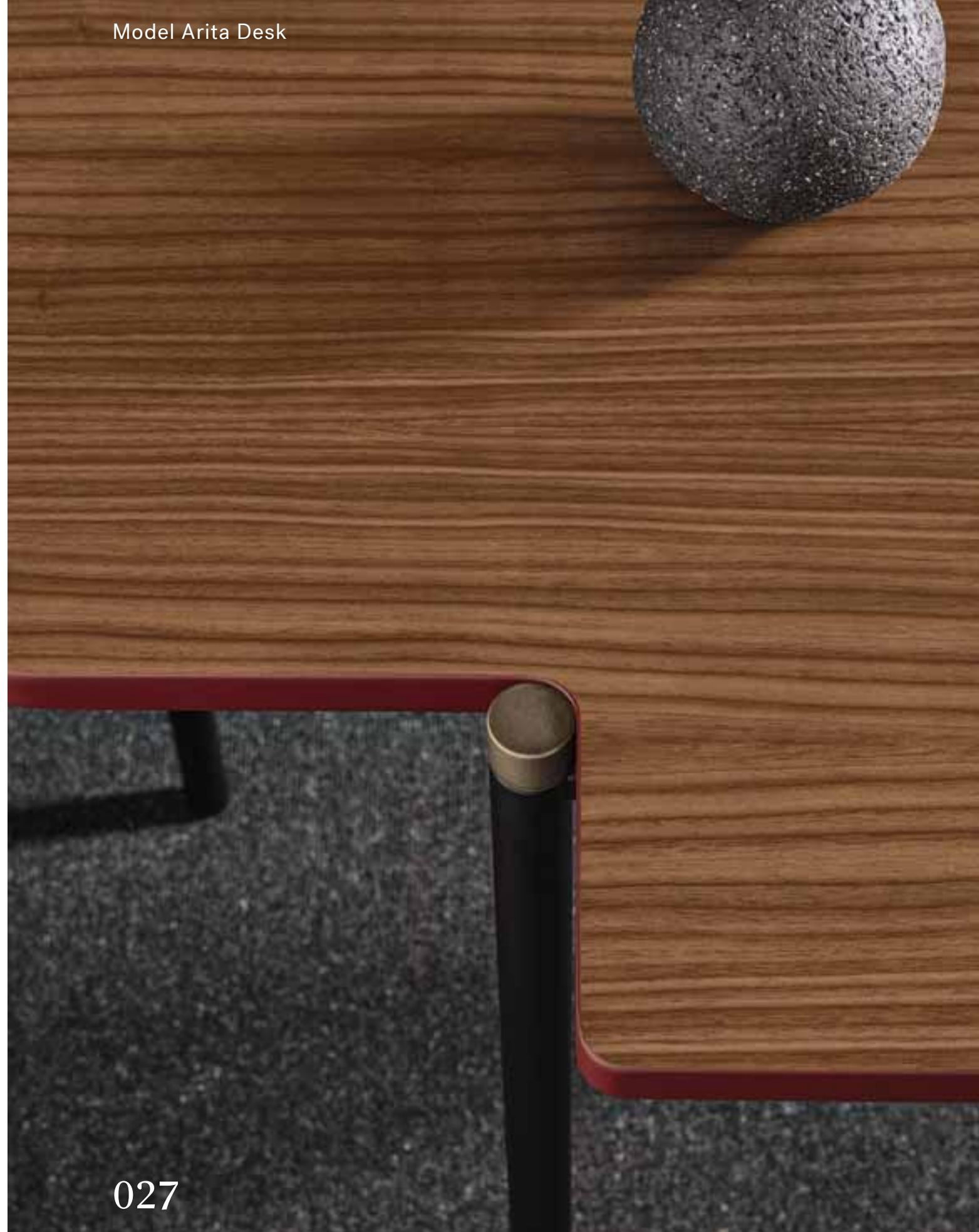



→ Arita Desk / FG 520.01



030

Arita Consolle,



→ Arita Consolle / FG 520.02

031

→ Arita Consolle / FG 520.02



032



033



Arita Coffee Table,



→ Arita CT / FG 520.00



→ Arita CT / FG 520.00



Otto,



(It) sospeso da terra e sorretto da una struttura dalle linee delicate, il letto Otto si distingue per il rivestimento totalmente in pelle e per il particolare disegno fluido e avvolgente della testata imbottita pensata per facilitare i momenti di lettura. Caratteri distintivi sono la sinuosa curva che raccorda testata e giroletto, e il segno netto orizzontale al centro della testata che raccoglie e arriccia la pelle del rivestimento accentuando il senso di comfort.

(En) *suspended from the ground and supported by a structure with delicate lines, the Otto bed stands out for its full leather upholstery and for the particular fluid and enveloping design of the padded headboard, conceived to ease the moments dedicated to reading. Distinctive features are the sinuous curve that connects the headboard to the bed frame, and the sharp horizontal stroke in the center of the headboard that gathers and wrinkles the leather of the upholstery, accentuating the sense of comfort.*



→ Otto 180 / FG 517.05
→ Motif 35 / FG 509.02



040

041

Gast,



(It) accogliente e protettivo, Gast è un divano in cui convive un'anima d'ispirazione classica tipica dei divani dei primi del '900 mescolata con l'ironia degli imbottiti degli anni '60, reinterpretato in chiave contemporanea. La voluminosità importante delle parti imbottite interne è resa più leggera dal disegno netto e lineare della struttura contenitiva esterna, caratteristiche che lo rendono unico nel suo genere. Carattere distintivo della collezione sono le cuciture, studiate minuziosamente per enfatizzare il suo disegno e la sua morbidezza.

(En) *welcoming and protective, Gast is a sofa in which a soul of classic inspiration, typical of the early XX century sofas, coexists with the irony of the '60s upholstered furniture, reinterpreted in a contemporary key. The substantial volume of the inner padded parts is made lighter by the clean and linear design of the outer containment structure, characteristics that make it unique in its kind. The distinctive trait of this collection of sofas is represented by the seams, accurately studied to emphasize its design and its softness.*



→ Gast 210 / FG 520.00
→ Gast 240 / FG 521.01





→ Gast 240 / FG 521.01
→ Arita CT / FG 520.00

2

1



Company Reportage:





OT 082

OT 900

OT-808

PE15-0875
PR7220019C
PELLE ARR.#07-715

PE15-0859
PR7220019C
PELLE ARR.#07-715

PE17-0807
PR7120019CW
PELLE ARR.#07-712

PE17-0287
PR7120019CW
PELLE ARR.#07-712 ROSSO CHILI

PE15-1450
PR7150019CX
PELLE ARR.#07-715 FIAMMA

PE14-0967
PR606001RPS
PELLE ARR.#07-606 CASTAGNA



(It)

È ormai dal 1921 che l'azienda, forte di una lunga tradizione familiare, tratta il cuoio e la pelle con cura, competenza ed esperienza. Il bagaglio culturale e tecnico di Frag è stato nel tempo affiancato da una continua ricerca orientata, da un lato, verso l'acquisizione di un'expertise nella lavorazione di altri materiali, dall'altro, verso forme sempre nuove, grazie al contributo e alla creatività di designer internazionali. Atmosfere suggestive, linee contemporanee, finiture e materiali preziosi e una magistrale attenzione verso i dettagli: sono questi gli elementi che oggi definiscono la collezione di Frag, dando vita ad un catalogo stilisticamente coerente con la sua lunga storia produttiva, fatto di linee nuove e materiali senza tempo.

(En)

It is from 1921 that the company, relying on a long family tradition, has been treating leather with dedication, mastery and experience. Frag's cultural and technical baggage has been supported over time by continuous research focused, on the one hand, on the acquisition of expertise in the processing of other materials, and on the other hand, on ever innovative shapes, thanks to the contribution and creativity of international designers. Suggestive moods, contemporary lines, precious finishes and materials, along with special attention to detail define Frag's collections today, creating a catalogue that is stylistically consistent with its long production history and that features new lines and timeless materials.

Frag, since 1921



Company Reportge



THE ASSOCIATED HULLS

Frag, since 1921

Company Reportge



Frag, since 1921



Company Reportge





(It)

Le creazioni di Frag si fanno espressione di un linguaggio internazionale e portavoce di una qualità tutta made in Italy. Tale qualità deriva non solo dal pregio dei materiali, ma anche dall'eccellenza produttiva dell'azienda che affianca l'utilizzo di macchinari all'avanguardia con lavorazioni artigianali, come la cucitura del cuoio, realizzata con particolari macchine, caratteristiche della cucitura da selleria, dette "marcapunto".

Il lavoro comincia con l'attenta selezione del pellame, in seguito, grazie alla sua specializzazione tecnica e stilistica, Frag trasforma questi materiali tradizionali in un prodotto attuale e razionale. Il cuoio, di difficile manipolazione per la sua rigidità, viene così lavorato con maestria - assumendo una duplice valenza estetica, funzionale e strutturale - mentre le pelli, trattate con abilità, diventano molto di più di un semplice rivestimento.

(En)

Frag's designs express an international language, representative of the quality of Made in Italy. Such quality is not only the result of the value of the materials, but also of the company's production excellence, which combines the use of state-of-the-art equipment with an artisanal manufacturing process, such as the stitching of leather, carried out with special machines as featured in saddlery, so-called "marcapunto" (stitch markers). The work starts with the careful selection of the hides. Subsequently, thanks to its technical and stylistic specialisation, Frag transforms these traditional materials into a contemporary and functional product. Saddle leather, which is difficult to handle due to its stiffness, is thus skilfully processed - assuming an aesthetic, functional and structural value - whilst supple leather, treated with dexterity, becomes much more than mere upholstery.

Frag, since 1921

Company Reportge



Frag, since 1921



Company Reportge



Frag, since 1921



Company Reportge

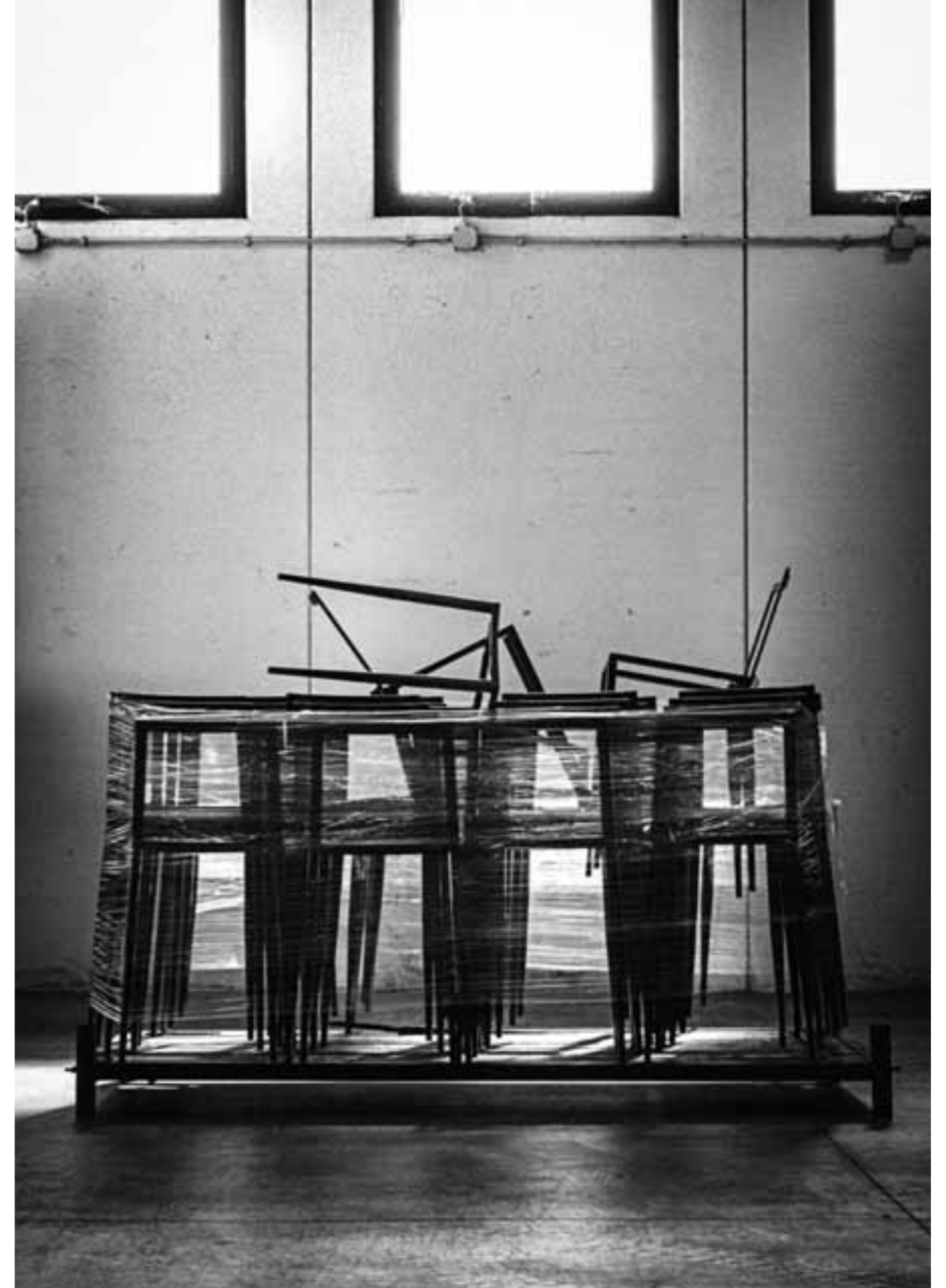

Frag, since 1921



Company Reportge



The Collection:

→ Eif / FG 497.00
→ Eif P / FG 497.01
→ Caribou 240 / FG 480.01



Model

design: Gordon Guillaumier

Elf,



(It) la famiglia di sedie, poltroncine e sgabelli mantiene un profilo rigoroso senza rinunciare al comfort, grazie alla morbida imbottitura e allo schienale flessibile, dando vita ad un oggetto fatto di nuove sinuosità dal gusto estremamente contemporaneo.

(En) *is a collection of chairs, armchairs and stools, with a clean-cut profile that doesn't compromise on comfort, thanks to the soft upholstery and flexible back, which produce a sinuous, curved item with a particularly contemporary flavour.*

051

→ Eif H / FG 497.02
→ Eif HP / FG 497.03



→ Eif / FG 497.00
→ Eif P / FG 497.01



052



053



→ Elf HP / FG 497.03

054



→ Elf / FG 497.00

055



→ Doni / 110 / FG 485.02
→ Elf B / FG 497.11

056



→ Elf GP / FG 497.12
→ Elf B / FG 497.11

057

Winnie,



→ Winnie sofa 240 / FG 483.02
→ Comb 100 / FG 487.01

(It) è una collezione composta da divano e poltrona, caratterizzati da forme generose e imbottiture che invitano al relax. La scocca rivestita in pelle o tessuto disegna seduta e schienale, curvandosi a formare una sorta di nido. Al suo interno un unico cuscino come schienale rivestito in pelle o tessuto curvato a formare una U, definisce uno spazio intimo, un rifugio, in cui sprofondare viziati dalla preziosa morbidezza del materiale.

(En) is a collection featuring a sofa and an armchair notable for their generous form and padding which invites relaxation. The shell is upholstered in leather or fabric, while the design of the seat and back curve to form a nest shape. Inside this is a single U-shaped cushion as a backrest, upholstered in leather or fabric. Winnie is a refuge, a private space in which to nestle, surrounded by the comforting softness of the materials.



→ Comb. 100 / FG 487.01
→ Winnie Sofa 240 / FG 483.02
→ Winnie / FG 483.00

→ Winnie Sofa 200 / FG 483.01





064



065



→ Winnie / FG 483.00
→ Doni 62 / FG 485.01

Artù,



(It) archetipo del tavolo da pranzo rotondo, è un oggetto dalle forme importanti e dal carattere sontuoso, dedicato ai dining più lussuosi e alle sale riunione più ricercate. La base del tavolo, rivestita in morbida pelle e impreziosita da un basamento e da profili in ottone brunito, dichiara immediatamente lo statement di questo oggetto dalla forte personalità.

(En) *the archetypal round dining table, its impressive shape and distinguished appearance make it suitable for the most luxurious dining areas and elegant meeting rooms. The base of the table, upholstered in soft leather and enhanced by a burnished brass base and profiling, marks this out as a piece with a strong personality that makes an immediate statement.*

→ Artù 160 / FG 494.00
→ Lazy Susan / AC 494.01



→ Artù 160 / FG 94.00





→ Artù 180 / FG 494.01
→ Eiff / FG 497.02

→ Artù 200 / FG 494.02



074



075

Wilton,

→ Wilton 1 / FG 511.04 + 511.22
→ Motif 35 / FG 509.02

(It) è una collezione di divani chiusi ed elementi modulari leggermente imbottita e rivestita pelle o tessuto. Le forme nette della scocca definiscono il profilo squadrato di questa famiglia come fosse composta da rettangoli leggermente curvati, a creare una sorta di nido-origami. All'interno, la morbidezza dei cuscini e le dimensioni generose della seduta invitano al relax e ad una nuova forma di convivialità. Quattro sottili piedini metallici contribuiscono a rendere aerea e leggera la collezione di divani.

(En) is a collection of fixed sofas and modular elements characterized by a lightly padded body that is upholstered in leather or fabric. The clear shapes of the body define the square profile of this family as if it were composed of slightly curved rectangles, creating a sort of nest-origami. The softness of the cushions and the generous dimensions of the seat invite relaxation and a new form of conviviality. Four thin metal feet contribute to making the collection airy and light.



→ Hollow / FG 482.00
→ Wilton 250 / FG 511.02
→ Wilton 230 / FG 511.00

→ Privé A / FG 478.01
→ Square 52/42 / FG 465.61
→ Square 140 / FG 465.56



→ Wilton 1 / FG 511.04+FG 511.22
→ Wilton 230 / FG 511.00



→ Motif 35 / FG 509.02
→ Motif 100 / FG 509.01
→ Morgans / FG 507.00



→ Square 52/42 / FG 465.61
→ Privé C / FG 478.10

→ Wilton 230 / FG 511.00
→ Wilton 3 / FG 511.04 + 511.10
→ Square 100 / FG 465.54

Sofy,

(It) si concretizza in un accogliente guscio rivestito in morbida pelle accostato in un piacevole contrasto materico e cromatico con le gambe in legno di frassino tinto noce. La sapiente lavorazione della pelle si riconosce dai preziosi dettagli di questa seduta, come la cucitura al centro dello schienale che crea un elegante effetto decorativo.

(En) *is a welcoming shell upholstered in leather that is juxtaposed, in a pleasant structural and colour contrast, with walnut-tinted ash wood legs. The skilful leatherwork can be seen in the precious details in this chair, such as the stitching at the centre of the back, which gives it an elegant decorative touch.*



→ Sofy FG 446.00



Riviera,



(It) è una lounge armchair in cui sono leggibili sia richiami modernisti, per l'utilizzo del tubolare metallico, sia un'impronta contemporanea e decorativa, per l'utilizzo della finitura ottone brunito graffiato e l'accostamento tra la pelle o tessuto dei cuscini ed il cuoio di seduta e schienale.

(En) is a lounge chair which displays hints of modernism in its use of metallic tubing, while a contemporary, decorative influence is provided by the burnished brass finish and the combination of the fabric or leather-upholstered cushions and the saddle leather on the seat and back.

→ Riviera / FG 499.00



090



091

Morgans,



(It) è una libreria che utilizza come montanti due barre verticali a sezione rettangolare accostate che incrociano e fissano cinque barre orizzontali su ogni lato. Il disegno degli elementi metallici, dallo stile quasi industriale e costruttivista, crea un affascinante contrasto con la ricercatezza della finitura in ottone brunito e con il rivestimento in prezioso cuoio delle mensole, creando un oggetto dal carattere peculiare e dall'estetica decorativa.

(En) is a bookshelf that uses two vertical rectangular bars placed side by side that cross and fix five horizontal bars on each side. The design of the metallic elements, with an almost industrial and constructivist style, creates a fascinating contrast with the refinement of the burnished brass finish and the precious leather covering of the shelves, creating an object with a peculiar character and a decorative aesthetic.

→ Morgans / FG 507.00



→ Olimpia P / FG 501.01
→ Twain / FG 444.00



Olimpia,



(It) è una seduta che unisce estetica e funzione, in un gioco in cui la struttura metallica sostiene e ricalca la silhouette di seduta e schienale senza quasi toccarla. La scocca è impreziosita da impunture capitonné confermando la personalità decorativa e contemporanea di Olimpia.

(En) *combines aesthetics and functionality, with a metal frame that supports and traces the outline of the seat and backrest almost without touching it. The body is embellished with capitonné stitching which gives it the signature decorative and contemporary Olimpia style.*

→ Olimpia P / FG 501.01
→ Olimpia / FG 501.00





Otis,

(It) è una collezione di divani chiusi ed elementi componibili caratterizzati da forme di ispirazione classica ma con dettagli e proporzioni contemporanei, un profilo aristocratico e uno stile maschile. Lo spazioso cuscino di seduta e l'elegante bracciolo a martello, rivestiti in pelle o tessuto, sono resi confortevoli da una morbida e abbondante imbottitura. Quattro piedini metallici in tubolare rotondo, fissati alla struttura attraverso una sottile piastra metallica, completano il progetto diventandone anche sobrio vezzo ornamentale.

(En) *is a collection of fixed sofas and modular elements characterized by classically inspired forms but with contemporary details and proportions, aristocratic profile and masculine style. The spacious seat cushion and the elegant hammer armrest, upholstered in leather or fabric, are made comfortable by a soft and plentiful padding. Four round tubular metal feet, fixed to the structure through a thin metal plate, complete the project, with a sober ornamental quirk.*



→ Public L / FG 506.02
→ Square 100 / FG 465.54

→ Otis 230 / FG 510.00
→ Otis 250 / FG 510.01

→ Otis 250 / FG 510.01





→ Otis 3 / FG 510.16 + 510.21
→ Comb 40 / FG 487.02
→ Morgans / FG 507.00
→ Cocoon / FG 495.00
→ Cocoon Pouf / FG 495.01

→ Motif 100 / FG 509.01
→ Motif 35 / FG 509.02
→ Riviera / FG 499.00



Model

design: Alanogia Project

Motif,

(It) è una famiglia di tavolini con piano rivestito in cuoio intarsiato, la cui estetica ricca e decorativa si contrappone alla semplicità della struttura in tondino metallico a sezione quadra che definisce le gambe e quattro assi incrociate che le uniscono. Il disegno del top viene eseguito attraverso un taglio estremamente preciso delle diverse forme in cuoio, successivamente accostate attraverso una minuziosa lavorazione artigianale.

(En) is a family of tables with an inlaid leather tabletop, whose ornate and decorative aesthetic creates contrast with the simplicity of the metal square section frame which defines the legs and the four crossed planks. The leather inlay design of the tabletop is carried out with a high-precision cut of the leather into different shapes, which are then bonded together with meticulous craftsmanship.

→ Motif 35 / FG 509.02
→ Motif 55 / FG 509.00
→ Motif 100 / FG 509.01





Dindi,



(It) intramontabile evergreen, classica seduta completamente rivestita in cuoio, è un oggetto che si adatta ad ogni luogo dell'abitare, inserendosi con grazia negli spazi più minimali e in quelli più sontuosi. Lo schienale, realizzato in uno speciale acciaio armonico flessibile con memoria, aggiunge movimento in un equilibrio perfetto tra estetica e comodità.

(En) *a timeless evergreen, this classic chair, fully upholstered in saddle leather, is an object that suits every setting, which can be gracefully integrated into the most minimalist of spaces as well as the most sumptuous ones. The back, in special flexible spring "memory" steel, conveys dynamism to a perfect balance between beauty and comfort.*

→ Public L / FG 506.02
→ Square 34/24 / FG 465.60

Public,

(It) è una collezione composta da sedia e poltroncina, poltrona lounge e divanetto due posti, interamente imbottita e rivestita in pelle o tessuto. Sedia e poltroncina sono come disegnate da un'unica linea che definisce gambe, seduta, schienale e i braccioli arrotondati che, nella sedia, si trasformano nella linea retta che va a chiudere lo schienale. La lounge mantiene le forme e gli stilemi della collezione, abbassati e ampliati per dare maggiore comfort. Il divanetto, partendo dalle dimensioni e dalle proporzioni della lounge, chiude e completa la famiglia.

(En) is a collection consisting of chair and armchair, lounge chair and two-seater sofa, entirely padded and upholstered in leather or fabric. Chair and armchair seem to be designed by a single line that defines legs, seat, backrest and rounded armrests that, in the chair, are transformed into the straight line that closes the backrest. The lounge maintains the shapes and styles of the collection, lowered and extended for greater comfort. The sofa, following the dimensions and proportions of the lounge, completes the family.



→ Artù 160 / FG 494.00
→ Public / FG 506.00
→ Public P / FG 506.01
→ Bak Bookcase / FG 440.10



→ Public TS / FG 506.03
→ Public L / FG 506.02





→ Public / FG 506.00
→ Public P / FG 506.01



Doa,



(It) si configura come la classica seduta con struttura in legno a vista, un arredo intramontabile in grado di valorizzare differenti ambienti domestici. La base e le gambe affusolate sostengono il cuscino di seduta e lo schienale, disegnando una silhouette armoniosa ed accogliente.

(En) *is a classic chair with a visible wooden frame, a timeless piece that will enhance many different rooms of the home. The base and tapered walnut legs support the seat and back cushioning, creating a harmonious, welcoming silhouette.*

→ Doa P / FG 464.02
→ Doa / FG 464.03



Cocoon,



(It) è una collezione composta da poltrona lounge con poggiatesta, fatta di forme avvolgenti, armoniche, equilibrate e da sapienti accostamenti materici: perfetto connubio tra formalismo estetico e comfort, testimonia una grande abilità nel mixare e lavorare materiali e rivestimenti differenti.

(En) is a collection featuring a lounge chair with a footrest, combining enveloping, harmonious, balanced lines with skilfully paired materials: a perfect marriage of aesthetic formalism and comfort, evidence of an ability to blend and work with different materials and upholsteries.



→ Clubby Pouf / FG 493.10

→ Cocoon / FG 495.00
→ Cocoon Pouf / FG 495.01

Viae,



→ Viae Valet Stand / FG 484.50

(It) si ispira ai ciottoli delle antiche strade romane la cui forma liscia e levigata deriva dall'uso e dal tempo. Una collezione composta da due tavolini e un appendiabiti - svuota tasche, Viae riesce ad unire funzionalità e vanità in un oggetto del desiderio dal carattere prezioso dedicato agli ambienti più intimi della casa.

(En) *is inspired by the cobblestones of ancient Roman roads, shaped and polished by time and wear. A collection consisting of two coffee tables and a clothes stand - valet tray, Viae successfully marries functionality and design in a desirable, luxurious item suitable for the most intimate domestic environments.*



→ Viae 5 / FG 484.00
→ Viae 3 / FG 484.01



→ Viae 5 / FG 484.00
→ Viae 3 / FG 484.01



→ Viae 3 / FG 484.01
→ Viae 5 / FG 484.00



→ Viae Valet Stand / FG 484.50

Clubby,



(It) è una famiglia composta da club armchair e pouf dalle linee tondeggianti, ispirati alle poltroncine dei fumoir dei circoli parigini. Le proporzioni e le forme di questa famiglia, infatti, la rendono particolarmente adatta agli spazi comuni e agli utilizzi più legati al mondo del contract.

(En) a range consisting of a club armchair and pouf with rounded contours, inspired by the chairs found in Parisian fumoirs. The proportions and lines of this series make it ideal for public areas and the uses commonly requested by contract clients.



→ Clubby / FG 493.20



→ Clubby / FG 493.20



→ Clubby / FG 493.20
→ Clubby Pouf / FG 493.10
→ Doni 62 / FG 485.01

→ Clubby / FG 493.30
→ Clubby Pouf / FG 493.10



Sahrai,



(It) lounge chair, pouf e coffee table ispirati alle tradizionali poltroncine da regista. La struttura portante si distingue infatti per il tipico incrocio ad 'X' che il designer ha utilizzato come sostegno per tutta la collezione, cambiandone però il verso in orizzontale.

(En) lounge chair, pouf and coffee table inspired by the traditional director's chair. The bearing structure is distinguished by the typical X cross that the designer has used as supporting element for the whole collection, changing only its horizontal position.



→ Sahrai L / FG 471.00
→ Sahrai Pouf / FG 471.01
→ Sahrai CT / FG 471.02



→ Sahrai L / FG 471.00
→ Sahrai Pouf / FG 471.01



→ Sahrai CT / FG 471.02

Bak Family,



(It) gioca con contrasti materici ponderati dati dall'accostamento della struttura in tubolare metallico e dettagli in pelle mixati con piani in legno - per tavolo, tavolini e libreria - e morbide imbottiture - servomuto e panca con cuscino -, declinando una famiglia composta da arredi e complementi dedicati alla zona notte e agli spazi living più ricercati.

(En) *plays with well thought-out material contrasts resulting from the pairing of the tubular metal structure and leather details combined with the wooden shelves - for table, accent tables and bookcase - and with soft padding - for the valet stand and bench with cushion - that conjugate a collection of furniture and accessories dedicated to the bedroom and to the most refined living spaces.*



→ Iki W / FG 333.05
→ Iki PW / FG 333.06

Bak Table,



→ Bak table / FG 442.00



→ Bak Table / FG 422.00
→ Iki W / FG 333.05
→ Iki PW / FG 333.06

Bak Bench:



→ Bak Bench / FG 441.01

154

Bak Coffe Table:



→ Bak CT H / FG 442.02
→ Bak CT / FG 442.01

155



→ Bak CT O / FG 442.03
→ Bak CT HO / FG 442.04





→ Bak Vaite Stand / FG 440.00
 → Maio / FG 421.00

Bak Valet Stand:



→ Bak Mirror / FG 440.01



Bak Bookcase:

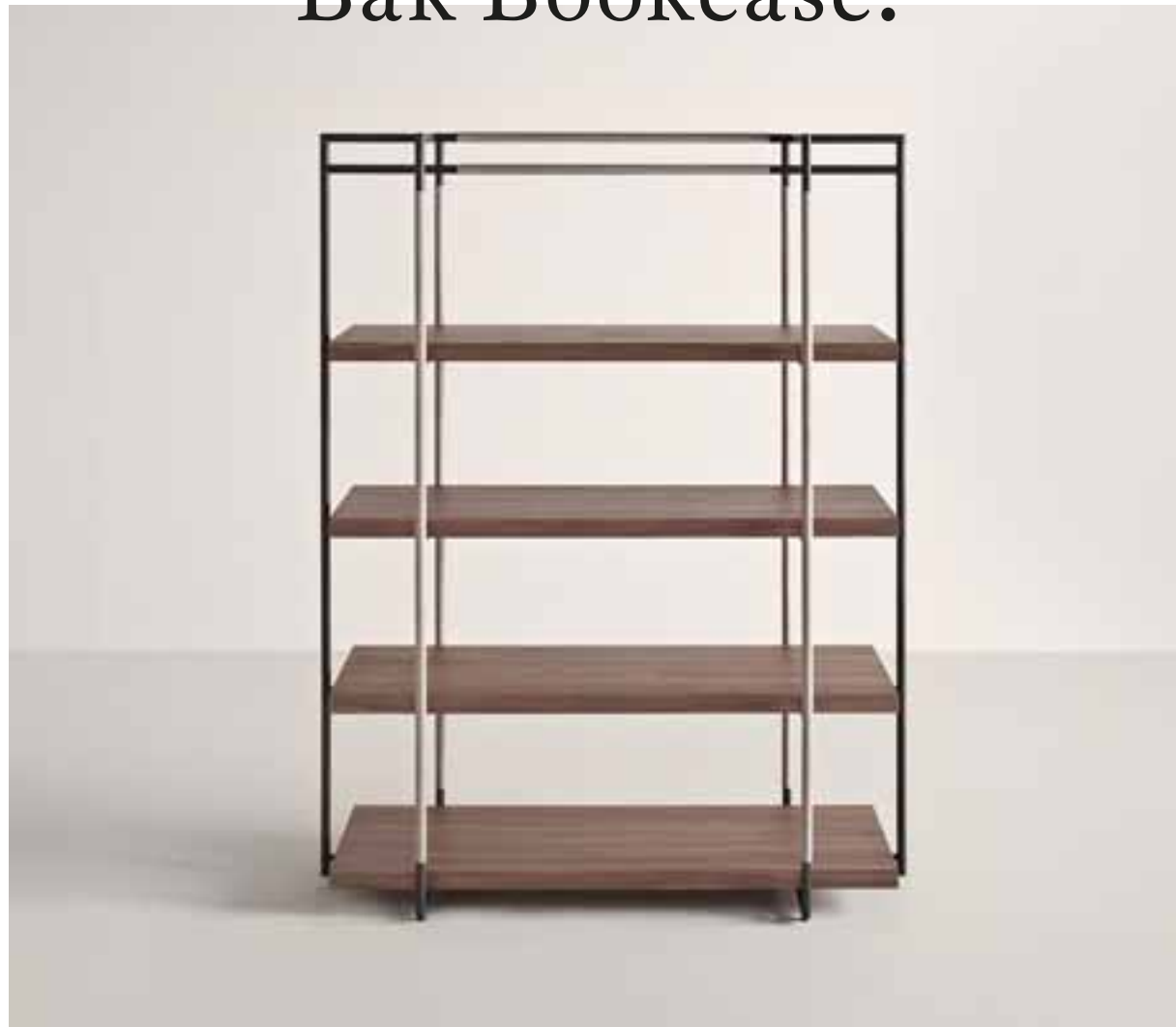

→ Bak Bookcase / FG 440.10





Square Family,

(It) è una famiglia dalle linee rigorose composta da poltroncina, lounge chair, sgabello e tavolini, impreziositi dall'uso di pelle, cuoio, marmi e finiture particolari. Quattro sottili gambe in metallo fungono da struttura e da tratto distintivo di questa collezione, slanciando e regalando leggerezza a questi oggetti dal carattere minimale.

(En) is a collection with clean lines composed of armchair, lounge chair, stools and accent tables, embellished by the use of leather or saddle leather, marble and special finishes. Four slim and slender metal legs form the frame and the distinctive feature of this line, imparting sharpness and airiness to these minimalistic objects.



→ Bak Table / FG 442.00
→ Square (bi-material) / FG 465.00

Square Armchair,





→ Square L (mono-material) / FG 465.21
→ Square (mono-material) / FG 465.20



→ Square C (bi-material) / FG 465.02



→ Square L (bi-material) / FG 465.01
→ Square 42 / FG 465.53



→ Square 34/24 / FG 465.60
→ Square 42 / FG 465.53

Square Table,



→ Square 52/42 / FG 465.61
→ Square 34/24 / FG 465.60

→ Square 140 / - 465.56
→ Square 100 / FG 465.54



→ Public L / FG 506.02
→ Square 140 / FG 465.65
→ Square 24 / FG 465.51





Hudson,



→ Hudson / FG 477.00
→ Square 52 / FG 465.52

(It) combina un design razionale e raffinato insieme ad un'esperienza di calore visivo e tattile, configurandosi come un arredo aristocratico rivisto in chiave contemporanea. I dettagli e la lavorazione minuziosa di questo day bed ne fanno il perfetto protagonista di un abitare quotidiano sofisticato e ragionato.

(En) *combines rational and refined design with visual and tactile warmth, taking the form of an aristocratic piece of furniture updated with a contemporary touch. The details and meticulous workmanship of this day bed make it the perfect protagonist in a sophisticated coherent daily environment.*



→ Hudson / FG 477.00
→ Square 52 / FG 465.52



→ Hudson / FG 477.00



→ Bella P / FG 320.03
→ Bella / FG 320.01
→ Bak table / FG 442.00



Model

design: G+R Fauciglietti

Bella,

(It) deve il suo fascino senza tempo alla elegante figura slanciata e al profilo garbato, che ne fanno il perfetto archetipo della seduta in pelle. Lo schienale, realizzato in uno speciale acciaio armonico flessibile con memoria, aggiunge movimento in un equilibrio perfetto tra estetica e comodità.

(En) owes its timeless charm to its elegant, slender silhouette and its graceful profile, which make it the perfect archetypical leather chair. The back, in special flexible spring "memory" steel, conveys dynamism to a perfect balance between beauty and comfort.



→ Bella / FG 320.01



→ Bella H / FG 320.00

→ Bella H / FG 320.00





190



→ Bella CP FG 320.14
→ Bella GP FG 320.04

191



→ Bella P / FG 320.03



→ Bella L / FG 320.05

Ponza,



(It) nasce da un lavoro di ricerca sulla fine dialettica tra la morbidezza della pelle e il calore del legno, narrato attraverso uno stile pulito ed essenziale, la cura e il pregio dei particolari che caratterizzano questa famiglia evocativa.

(En) *is the fruit of research on the fine dialectics between the softness of leather and the warmth of wood, narrated through a clean and essential style, and through the care and value of details that distinguish this evocative collection.*





→ Ponza GP / FG 405.07





Model

design: Mist-o

Atelier,

(It) è una famiglia di tavoli di matrice geometrica, ispirata ai cavalletti che sostengono le tele dei pittori. Le basi dalle forme generose e scultoree sono composte ognuna da un disegno fatto di piatte metalliche incrociate, struttura e ornamento di questo progetto dal forte impatto estetico.

(En) is a collection of geometric tables, inspired by painters' easels. The base, with its generous, sculptural look, features a design made up of crossed steel plates, that constitutes both the structure and ornament of this object of high aesthetic impact.



→ Lilly / FG 408.00
→ Atelier 300 / FG 468.01



→ Atelier 240 / FG 468.00



Iki,



(It) gioca con la commistione dei materiali, mixando la pelle o il cuoio utilizzati per seduta e schienale con il metallo e il legno utilizzati per le gambe. Oggetto dal carattere disegnato ed elegante, questa seduta dal carattere forte si adatta ad ambienti contract più formali come a contemporanei paesaggi domestici.

(En) *plays with the blending of materials, combining leather or saddle leather used for the seat and backrest with the metal and wood used for the legs. An object with an elegant design, this chair with its strong features suits formal public spaces as well as contemporary home settings.*

→ Iki W / FG 333.05
→ Iki PW / FG 333.06





Privé,

(It) unisce ispirazioni anni '60, linee contemporanee e materiali preziosi, facendo della cura per il particolare il proprio vezzo caratteristico. Questa collezione di mobili contenitori si compone di elementi di grande matericità - come la cassa in noce, i ripiani in vetro e i dettagli in pelle del top e degli accessori - insieme ad un disegno fatto da spessori sottili, bordature a 45° e alla leggerezza dei quattro sottili piedini in tondino acciaio scuro spazzolato.

(En) blends 1960s inspiration, contemporary lines and precious materials, turning attention to detail into its own characteristic charm. This storage furniture collection is made up of elements with a consistent texture - such as the walnut chest, the glass shelves and the leather details in the top and accessories - together with a design made up of slim lines, 45° borders and the subtlety of the four slim feet in dark brushed steel.





→ Privé A / FG 478.01
→ Maio / FG 421.00



→ Privé A / FG 478.01
→ Privé B / FG 478.00



Caribou,



→ Caribou 240 / FG480.01
→ Lyo / FG 352.00

(It) si ispira - nella forma delle quattro gambe in legno - all'intervento di Carlo Scarpa nell'aula Baratto dell'Università Ca' Foscari, dove le stampelle a Y reggono il soffitto della boiserie. Maestoso ed elegante, questo tavolo diventa emblema del calore e della solidità del legno, riadattato in chiave contemporanea da un design pulito e incisivo.

(En) *the shape of the four wooden legs is inspired by Carlo Scarpa's works in the Baratto Hall at Ca' Foscari University, where Y-shaped capitals support the boiserie ceiling. Stately and elegant, this table becomes a symbol of the warmth and soundness of wood, a contemporary adaptation featuring a clean and powerful design.*



→ Caribou 240 / FG 480.01
→ Lyo / FG 352.00



→ Caribou 240 / FG 480.01



222

223

Hollow,



→ Hollow / FG 482.00

(It) *forme monolitiche si contrappongono ad un comfort estremo, disegnando una lounge chair dalla personalità forte e dall'eleganza indiscutibile. Perfetta all'interno una situazione più formale Hollow riesce ad inserirsi con garbo anche all'interno di importanti ambienti domestici.*

(En) *monolithic shapes contrast with extreme comfort, in the design of this lounge chair with great personality and undeniable elegance. Perfect in a more formal setting, Hollow also fits nicely into larger rooms in the home.*



→ Hollow / FG 482.01





Kati,

(It) allo stesso tempo tradizionale e moderna, è una famiglia di sedute le cui linee squadrate e sottili ne caratterizzano la contemporaneità. Ispirata ad una linea classica tra le tipologie delle sedute in pelle, si presta a molteplici interpretazioni grazie all'ampia varietà di modelli e di basi disponibili.

(En) *both traditional and modern, this collection of chairs features square and subtle lines that emphasise their contemporary appearance. Inspired by a classic line of leather seats, it lends itself to multiple interpretations thanks to the wide variety of models and bases available.*



→ Kati / FG 414.00



→ Kati P / FG 415.00
→ Kati PZ / FG 415.02
→ Kati Q / FG 414.04

Bridge,



→ Nisida / FG 342.00
→ Bridge 270 / FG 453.02

(It) è un tavolo dalla forte impronta architettonica. Travi orizzontali e verticali si incontrano a formare lo scheletro che sostiene il piano dando vita ad un oggetto razionale ed essenziale che riesce ad inserirsi perfettamente nei più svariati contesti abitativi.

(En) is a table with a strong architectural character. Horizontal and vertical beams meet to form the frame that supports the top, thus creating a rational and functional object that can be perfectly introduced into the most diverse living contexts.



→ Bridge 270 / FG 453.02
→ Nisida / FG 342.00



→ Bridge 240 / FG 453.00





Aileron,

(It) è una famiglia di sedute caratterizzata da un'importante struttura curva in acciaio dalla linea fluida e armoniosa. La seduta e lo schienale, insieme ai cuscini laterali della versione lounge, creano un prodotto dove il comfort e lo stile si completano a vicenda.

(En) *is a collection of chairs characterised by a large curved steel structure with fluid and harmonious lines. The seat and back, together with the side cushions in the lounge version, create a product in which comfort and style complement each other.*



→ Aileron / FG 334.00



→ Aileron L / FG 334.01



→ Aileron / FG 334.00



Model

design: Gordon Guillaumier

Comb,

(It) racchiude una grande originalità espressiva insieme a una forte tensione verso la componente strutturale, riprendendo le finiture e gli stili decorativi degli anni '50 e '60 in una famiglia di tavolini preziosa e disegnata.

(En) *represents great expressive originality along with a great attention to the structural component, recycling finishes and stylistic elements from the 1950s and 60s into a range of preciously designed accent tables.*



→ Comb 100 / FG 487.01
→ Maio / FG 421.00



→ Comb 100 / FG 487.01



→ Comb 40 / FG 487.02

Nisida,



→ Nisida P / FG 342.01
→ Nisida / FG 342.00
→ Argor 140 / FG 404.00

(It) sofisticata nella sua semplicità, conquista con la sua duplice valenza “classica” e “moderna”. Disponibile in differenti varianti, Nisida è costituita da una struttura in alluminio completamente rivestita in cuoio, dove la speciale lavorazione da vita ad una seduta incredibilmente contemporanea.

(En) *sophisticated in its simplicity, it captures with its twofold “classic” and “modern” aspect. Available in several versions, Nisida is made up of an aluminium frame fully upholstered in saddle leather, where special workmanship creates an incredibly contemporary chair.*

→ Nisida P / FG 342.01
→ Nisida / FG 342.00





Model

design: Gordon Guillaumier

Twain,

(It) riprende linee e concetti alla base del funzionalismo, principi di sobrietà e semplicità descritti in questo secretaire contemporaneo attraverso una struttura in metallo lineare impreziosita da ripiani e dettagli in pelle.

(En) revisits the lines and concepts at the root of functionalism, principles of sobriety and simplicity described in this contemporary secretary desk through a linear metal structure embellished with leather shelves and details.

→ Twain / FG 444.00





Model

design: Gordon Guillaumier

Lyo,

(It) sintetizza minimalismo e ricchezza dei materiali: le gambe in metallo cromato, unite tramite elementi incrociati dal profilo compatto, sostengono un unico foglio portante in cuoio sagomato. Un taglio centrale caratterizza e aggiunge fascino a questa seduta dal design contemporaneo.

(En) is a synthesis of minimalism and richness of materials: the chrome-plated metal legs, connected by compact crossed elements, support a single self-supporting sheet of moulded saddle leather. A central cut adds charm to this contemporary design chair.



262



→ Lyo / FG 352.00

263

Mea,



→ Mea C / FG 462.05
→ Mea H AR / FG 461.00
→ Bridge 270 / FG 453.02

(It) si presenta come una collezione pensata sia per sofisticati spazi domestici che per l'ufficio e l'home working, unendo l'anima tecnica di questa poltrona con le curve arrotondate e le proporzioni femminili che caratterizzano le sue forme.

(En) is a collection designed for sophisticated rooms in the home as well as for the (home) office, the technical aspect of this chair is combined with its round curves and feminine proportions that characterise its shape.



→ Mea HC / FG 461.05
→ Mea C / FG 462.05

→ Mea H AR / FG 461.00



→ Mea AR / FG 462.00
→ Mea H AR / FG 461.00

Fizzy,

(It) sfoggia, pur nella pulizia delle sue forme, dettagli preziosi e particolari sartoriali cuciti a mano, come la cucitura a punto cavallo, che rendono questo sgabello dal fusto regolabile un oggetto deciso e sofisticato.

(En) *even with its clean lines, it showcases valuable hand-stitched details, like the blanket stitching, which turns this height-adjustable stool into an incisive and sophisticated object.*

→ Fizzy / FG 458.00
→ Fizzy / FG 458.01





Model

design: Michele di Fonzo

Dante,

(It) è dominato dall'essenzialità della forma la cui particolarità consiste nel completo rivestimento in cuoio, impreziosito con discrezione dalle diverse impunture che disegnano sul piano del tavolo linee geometriche e nette.

(En) *is dominated by the sheer essence of its shape, which is especially due to the fact that it is completely clad in saddle leather, discretely embellished by the various stitching patterns that draw clean geometric lines on the table top.*



→ Dante 180 / FG 366.02
→ Iki PW / FG 333.06

→ Dante 150 / FG 366.00



Ele,



→ Ele / FG 457.00

(It) lega in uno speciale connubio i lineamenti sinuosi delle sue forme con il carattere forte del cuoio che la ricopre interamente. Le impunture a vista sagomano un leggero motivo grafico sullo schienale impreziosendo la seduta con elegante discrezione.

(En) binds in a special marriage the sinuous features of its shapes with the strength of saddle leather, which covers it completely. The visible stitching creates a delicate graphic motif on the backrest, embellishing the seat with elegant discretion.



→ Ele / FG 457.00

Argor,



→ Argor O / FG 404.01
→ Iki W / FG 333.05

(It) ricorda - con il suo imponente basamento centrale rivestito in cuoio - un pezzo di carta modellato, come a voler creare un origami le cui estremità sembrano "pizzicate" e piegate per dare origine con questo tavolo ad una sagoma tridimensionale.

(En) *with its imposing central base covered in saddle leather, is reminiscent of a sheet of paper, folded as if to make origami, whose tips seem "pinched" and shaped to create with this table a three-dimensional silhouette.*

→ Argor 140 / FG 404.00



→ Nisida P / FG 342.01
→ Nisida / FG 342.00

Latina,



(It) rappresenta la classica e intramontabile seduta in cuoio, dove il materiale riveste lo scheletro in acciaio armonico calzandolo come un abito e seguendo ogni singola linea e curvatura delle forme.

(En) *represents the classic, timeless saddle leather chair, where the material dresses the spring steel structure like a glove, following its every contour and curve.*



→ Latina / FG 260.00
→ Latina L / FG 285.00
→ Latina P / FG 262.01



→ Latina H / FG 261.00
→ Latina / FG 260.00





→ Latina CP / FG 265.04
→ Latina GP / FG 265.00





→ Heta Pouf / FG 426.01
→ Heta / FG 426.00

Heta,



(It) è composta da quattro aste in faggio a forma di H che sostengono il rivestimento sartoriale in cuoio, come se fosse in equilibrio su esili trampoli. Originale rivisitazione della classica bergère, abbinata al suo poggia piedi, diventa un oggetto affascinante e sofisticato da dedicare ai personali momenti di relax e tranquillità.

(En) consists of four beech wood beams arranged in an H-shape, which support the tailored saddle leather upholstery, as if balanced on stilts. Original update to the classic bergère, coordinated with its footrest, it becomes a fascinating and sophisticated object to be dedicated to personal moments of relaxation and peacefulness.



→ Heta / FG 426.00



→ Heta Pouf / FG 426.01

Doni,



(It) bar e lounge dining table dalle linee essenziali, contrappone al peso specifico ed estetico del top in marmo la leggerezza sottile del metallo che definisce la base, dando vita ad un arredo elegante, ideale, con le sue proporzioni e con il suo profilo, a completare sofisticate e intime zone lounge.

(En) bar and lounge dining table with basic lines in which the lightness of metal base contrasts with the specific weight and aesthetics of the marble top, thus creating an elegant piece of furniture, ideal, with its proportions and profile, for complementing sophisticated and intimate lounge areas.



300



→ Doni 62 / FG 485.01
→ Doni 73 / FG 485.00

301

→ Doni 100 / FG 485.02



302



303

Darling,



(It) esplora la capacità di Frag di utilizzare la pelle attraverso una particolare lavorazione della scocca, donando alla seduta linee tonde e flessuose, ispirate alle nobili armonie di un corpo femminile.

(En) *explores Frag's ability to use leather by means of the special crafting of the shell, that gives the seat round and flexible lines inspired by the sensual harmony of the female body.*



→ Darling 4 / FG 356.04

Maio,



→ Maio / FG 421.00

(It) indaga le potenzialità della pelle attraverso il suo rivestimento esclusivo e caratterizzante. Il disegno semplice e rettangolare di questo pouf viene interrotto da cuciture che ne seguono i profili e da una coppia di maniglie, decorazione e accessorio, in bilico tra funzionalità ed estetica.

(En) explores the potential of leather through its exclusive and distinguishing upholstery. The simple and rectangular design of this pouf is interrupted by seams that follow its profiles and a pair of handles, decoration and accessory, that strike a balance between functionality and aesthetics.

Lilly,



(It) è una famiglia di sedute imbottite dal gusto classico, interamente rivestite in cuoio o in pelle. Il suo disegno semplice si completa con un'attenzione accurata all'equilibrio delle proporzioni, alla sobrietà della linea e alla finezza dei particolari.

(En) is a collection of classic padded chairs, fully covered in leather or saddle leather. Its simple design is complemented by the thorough attention paid to the balance of proportions, to the sober lines and refined details.



→ Lilly / FG 408.00

312



→ Lilly H / FG 408.01

313



→ Linda / FG 413.00

Model

design: Michele di Fonzo

Linda,

(It) privilegia un design delle linee pulite ed eleganti che definiscono la sagoma di una seduta classica, senza tempo, con la sua leggera imbottitura e il rivestimento in pelle o tessuto, mentre il cuore della struttura in acciaio dona al prodotto leggerezza e solidità, rendendola un oggetto adatto ad ogni ambiente della casa.

(En) its design, made of clean and elegant contours, defines the outline of a classic, timeless chair with its light padding and leather or fabric upholstery, whilst the steel frame core imparts lightness and strength to the chair, thus making it an item suitable for any room in the home.



→ Linda / FG 413.00



Canouan,



(It) definisce un nuovo concetto di seduta in pelle, modulando seduta e schienale con una serie di imbottiture tubolari in grado di assicurare un comfort senza pari. L'accostamento con la finitura cromata della base dona leggerezza al progetto, facendo da contrappunto alle sue forme sinuose.

(En) *defines a new concept in leather seating, modulating the seat and back with ribbed padding that ensures unrivalled comfort. The juxtaposition with the chrome finish on the base provides this item with airiness, offsetting its sinuous shapes.*

Materials Mood:



Fig. 1 — Leathers

Fig. 11 — Leathers



Materials Moodboard

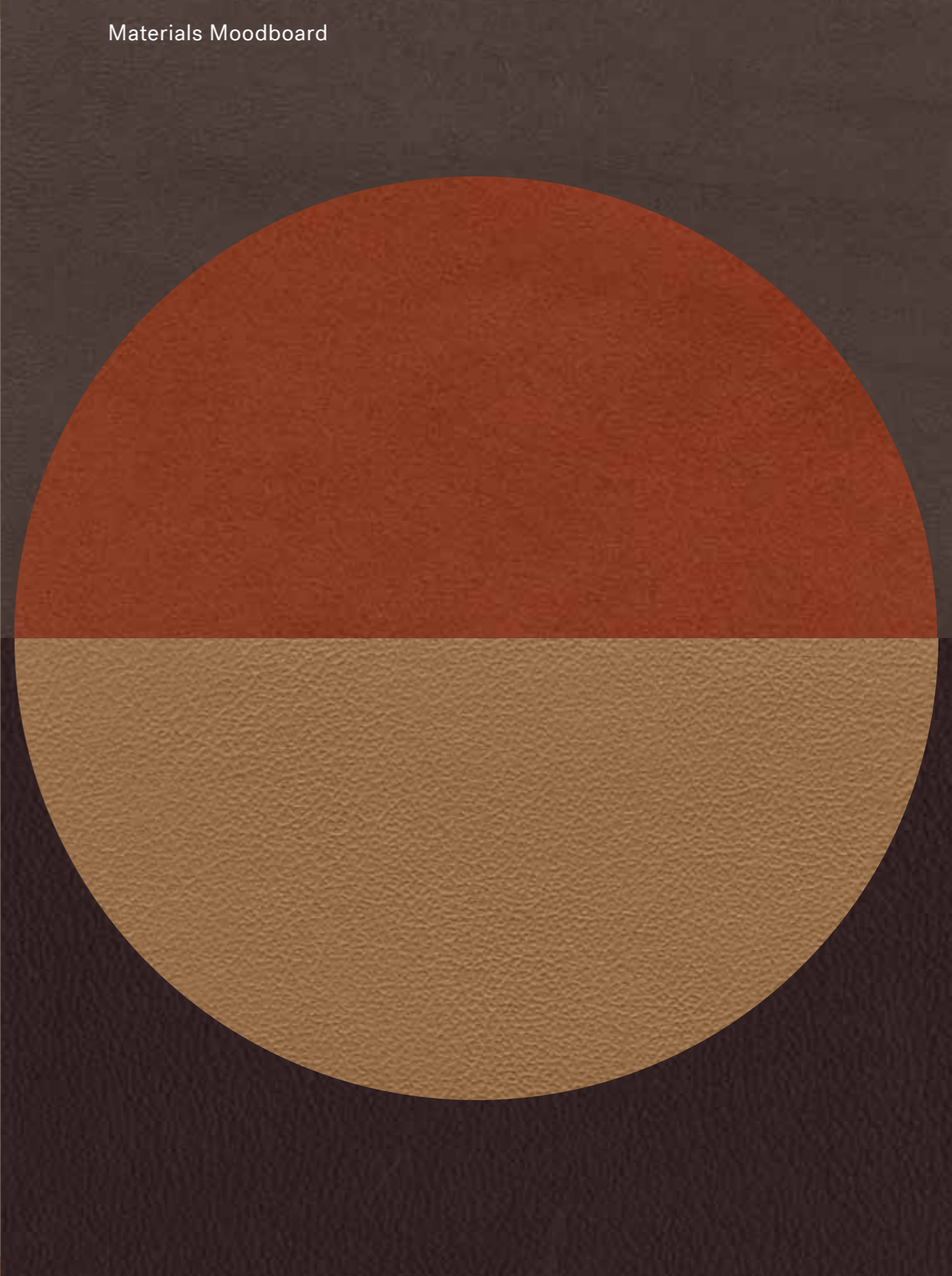



Fig. IV — Fabrics

Materials Moodboard

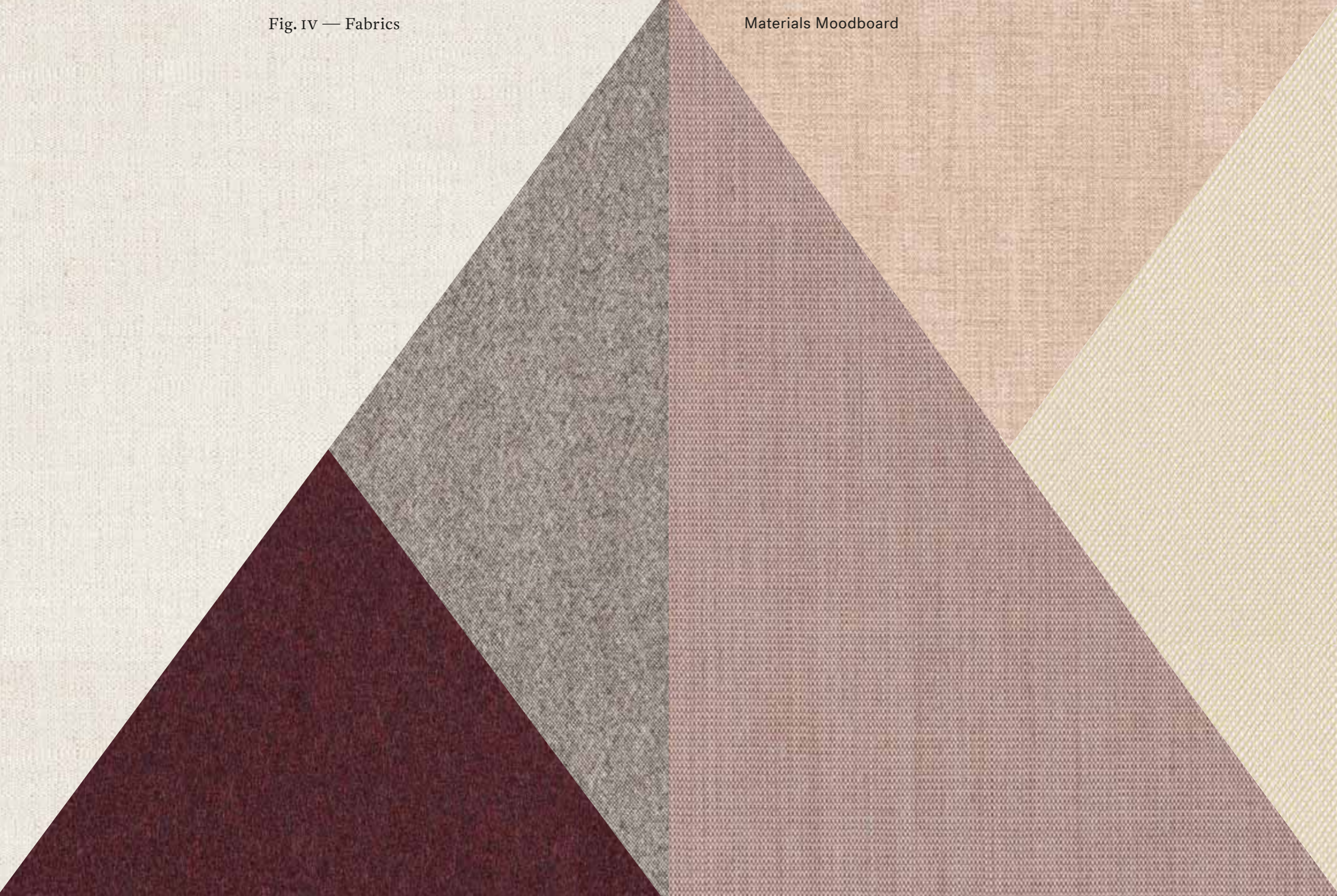
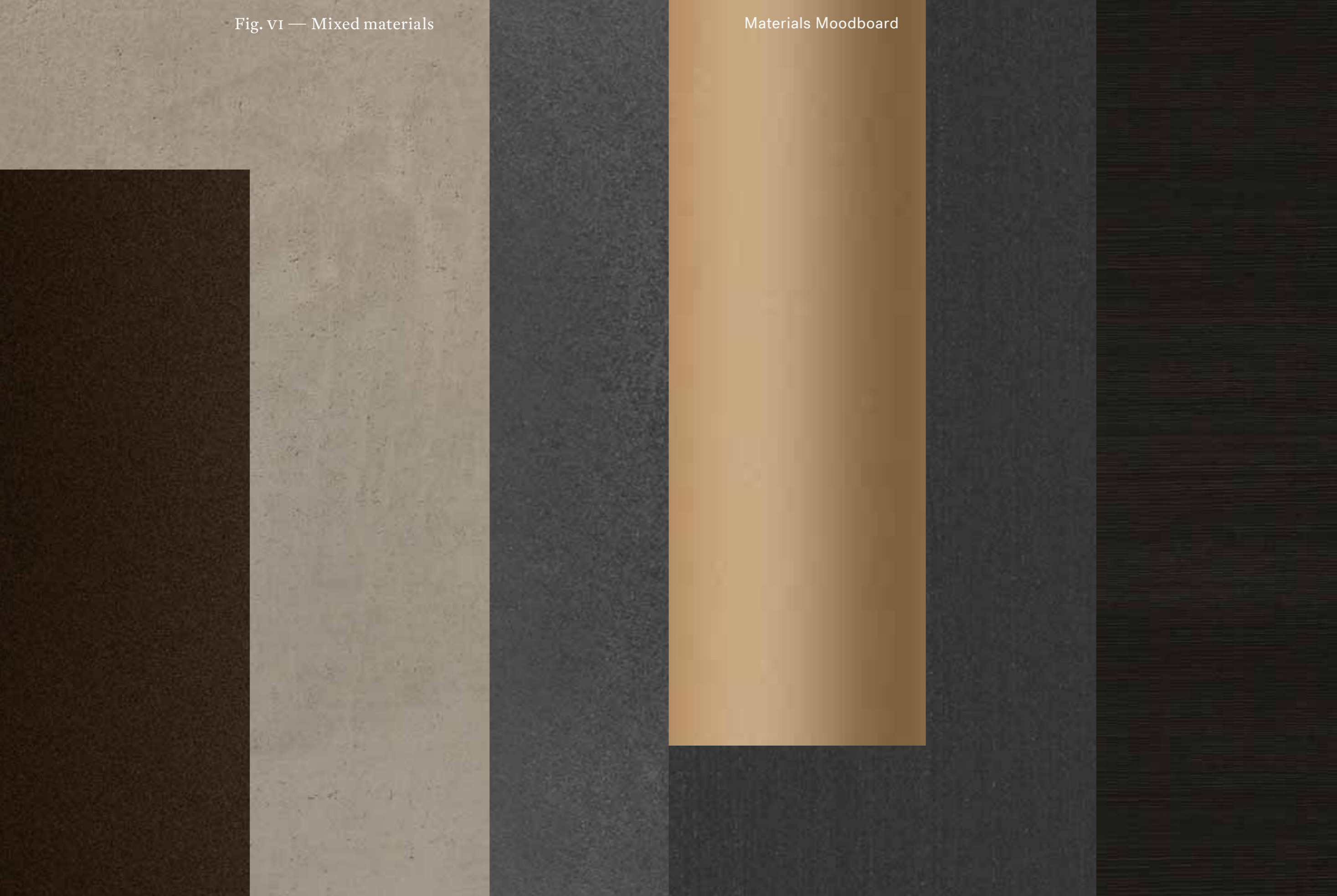

Fig. v — Fabrics

Materials Moodboard



Fig. VI — Mixed materials



Materials Moodboard

Contract Inspirations:



(It) Il know how quasi centenario e le tecnologie introdotte nella lavorazione dei materiali vengono messe a disposizione di architetti, decoratori, interior designers e developers per offrire un servizio specifico dedicato alle realizzazioni contract. Accanto alla vasta proposta di prodotti a catalogo, il servizio Tailor Made offerto dall'azienda permette infatti sia di realizzare prodotti ad hoc su disegno dei progettisti che di personalizzare con rivestimenti e finiture i prodotti a catalogo. La solida esperienza di Frag e la sua struttura versatile garantiscono un supporto concreto in tutti gli stadi di realizzazione, dalla fase progettuale ai servizi post vendita, assicurando un servizio contract dedicato, su misura ed estremamente professionale.

(En) *The company's know-how, dating back almost one hundred years, as well as technologies introduced into the manufacturing process, are made available to architects, decorators, interior designers and developers to provide a special service dedicated to contract projects. In addition to the extensive range of catalogue products, the Tailor-Made service provided by the company, in fact allows to either produce ad-hoc items to meet the designer's specifications or to personalise catalogue products with special upholstery and finishes. Frag's sound experience and its versatile structure guarantee effective support during every step of the production process, from the planning stage to after-sales assistance, thus ensuring dedicated, tailored and highly professional contract service.*



324



325

Inspiration #03
Ponza GP / FG 405.07
→ Family portrait p. 194—199
→ Details p. 348



326

327



Inspiration #05
Bella HP / FG 320.02
Bella H / FG 320.00
Family portrait p. 184—193
Details p. 340—341





Inspiration #06
Bella H / FG 320.00
Family portrait p. 184—193
Details p. 340—341

Doni 73 / 485.00
Family portrait p. 298—303
Details p. 361

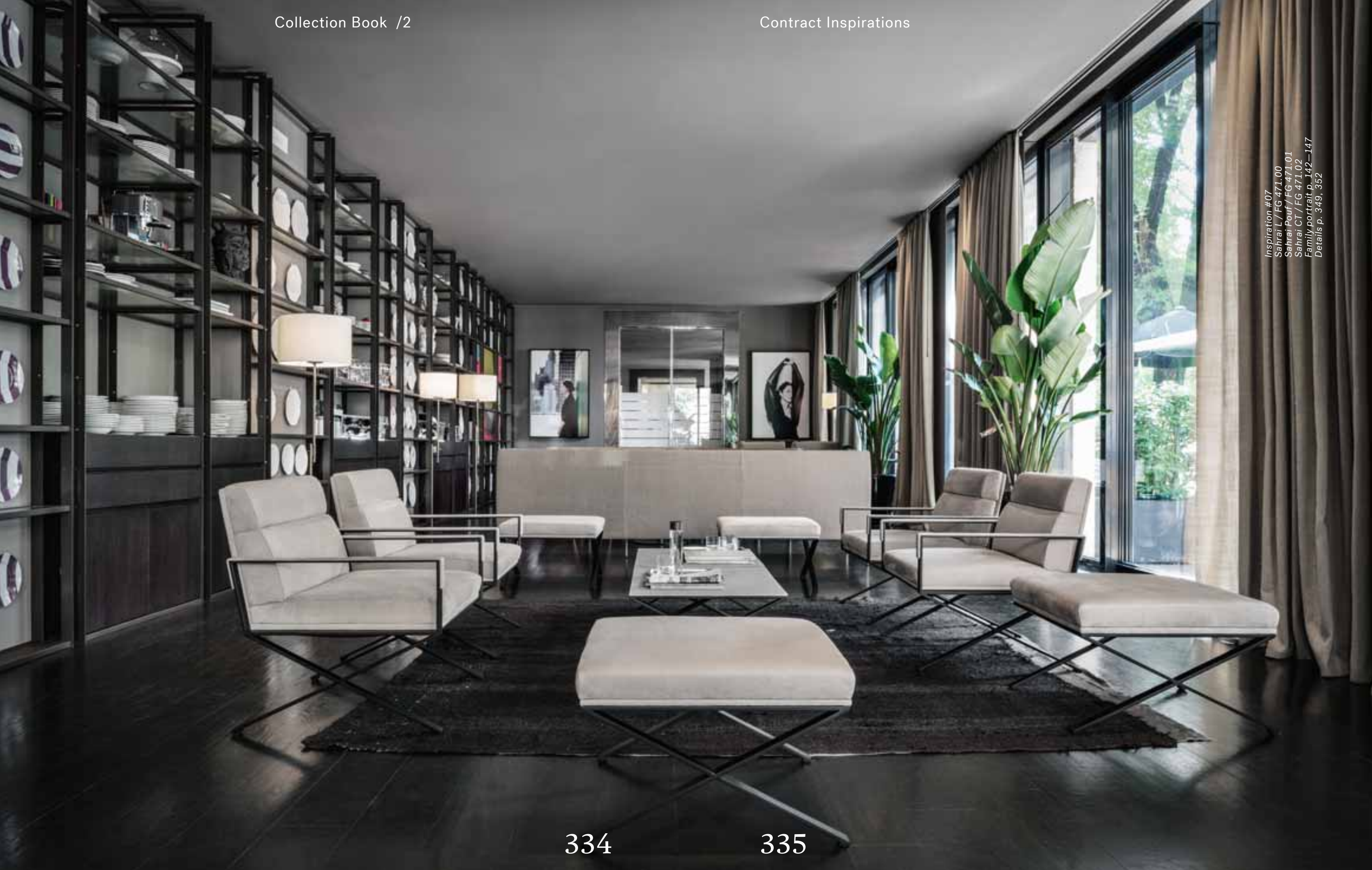

Inspiration #07
Sahrai L / FG 471.00
Sahrai Pouf / FG 471.01
Sahrai CT / FG 471.02
Family portrait p. 142-147
Details p. 349, 352

Inspiration #08
Square (bi-material) FG 465.00
Family portrait p. 164-177
Details p. 350



336

337

Technical Data:



Chairs →

Aileron

Famiglia di sedute con struttura e gambe in acciaio cromo lucido o verniciato. Sedile e schienale imbottiti in poliuretano espanso ignifugo e rivestiti in pelle o tessuto. / *Collection of armchairs with polished chrome or painted steel frame. Seat and back padded with flame-retardant polyurethane foam and upholstered in leather or fabric.*

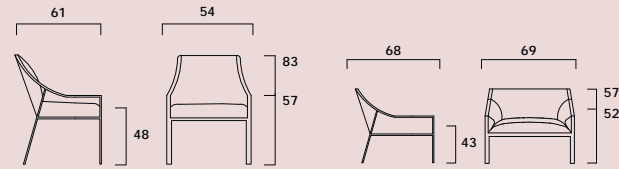

Aileron
Armchair
FG 334.00

Aileron L
Lounge armchair
FG 334.01

Bella

Famiglia di sedute imbottite in poliuretano espanso ignifugo e rivestite in pelle o tessuto. Struttura in acciaio, schienale flessibile con anima in acciaio armonico. Disponibile con gambe interamente rivestite in pelle, in legno di frassino o in metallo. Disponibile con schienale alto o basso, con e senza braccioli. Lo sgabello è disponibile con altezza fissa o regolabile con seduta imbottita e rivestita in pelle o tessuto e struttura in metallo cromo lucido o verniciato.

Collection of chairs and stools padded with flame-retardant polyurethane foam and upholstered in leather or fabric. Steel frame, flexible back with spring steel core. Available fully upholstered with leather or fabric or with ash wood or metal legs, with high or low back, with or without armrests. The stool is also available in a height-adjustable version, with a padded seat upholstered in leather or fabric and a polished chrome or painted base. The stools feature a fixed back.

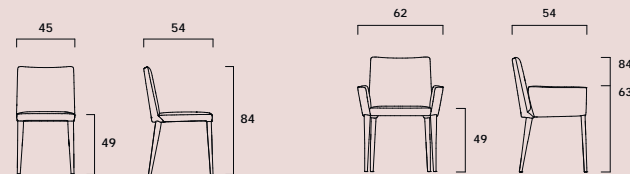

Bella
Side chair
FG 320.01

Bella P
Armchair
FG 320.03

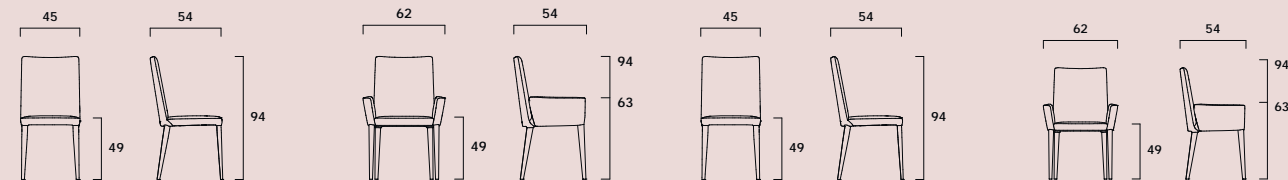

Bella H
Side chair
FG 320.00

Bella HP
Armchair
FG 320.02

Bella H GM metal legs
Side chair
FG 320.06

Bella HP GM metal legs
Armchair
FG 320.08

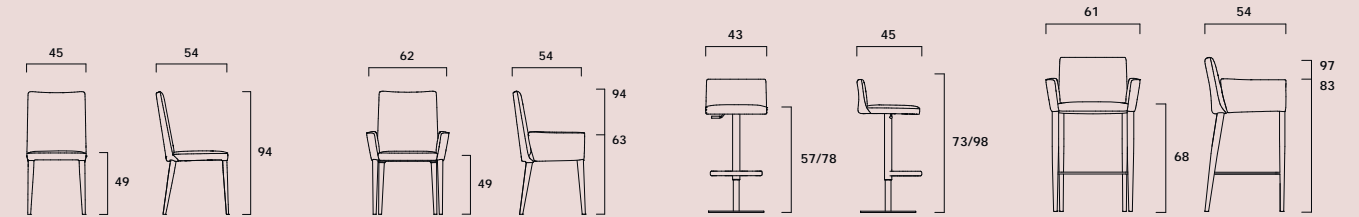

Bella HW wooden legs
Side chair
FG 320.10

Bella HPW wooden legs
Armchair
FG 320.12

Bella GP
Height-adjustable stool
FG 320.04

Bella CP
Stool
FG 320.14

Canouan

Seduta con scocca in multistrato imbottito in poliuretano espanso ignifugo e rivestita in pelle. Gambe in acciaio cromato lucido con ruote. / *Chair with multilayer shell padded with flame-retardant foam and upholstered in leather. Steel polished chrome swivel base, with casters.*

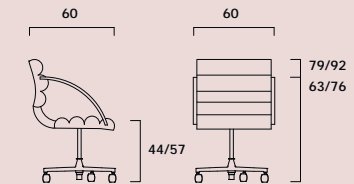

Canouan D
Office armchair
FG 282.03

Clubby

Famiglia di sedute completamente imbottite con basamento in metallo finitura ottone spazzolato. Poltrona lounge con basamento girevole, rivestita in pelle o tessuto, con guscio esterno rivestito in pelle, cuoio o tessuto. Pouf rivestito in pelle o tessuto. / *Collection of fully padded chairs with base finished in brushed brass. Lounge chair with swivel base, upholstered in leather or fabric, with an external shell upholstered in leather, saddle leather or fabric. Pouf upholstered in leather or fabric.*

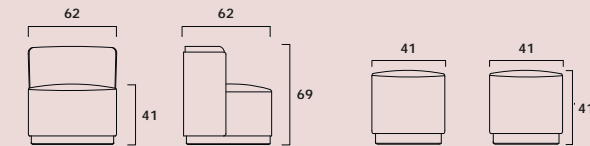

Clubby
Swivel armchair
FG 493.00
FG 493.20
FG 493.30

Clubby Pouf
Pouf
FG 493.10

Cocoon

Poltrona lounge e pouf imbottiti e rivestiti in pelle o tessuto, piedini in massello di noce. Lounge con scocca in alluminio rivestita in cuoio. / Lounge chair and pouf, padded and upholstered in leather or fabric, solid walnut feet. Back of chair with aluminium-core upholstered in saddle leather.

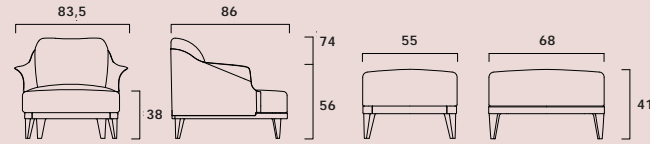

Cocoon
Lounge armchair
FG 495.00

Cocoon Pouf
Pouf
FG 495.01

Darling

Poltroncina imbottita e rivestita in pelle con scocca in poliuretano schiumato a freddo. Base in legno di faggio girevole. / Armchair upholstered in leather with cold-moulded polyurethane foam shell. Beech wood swivel base.

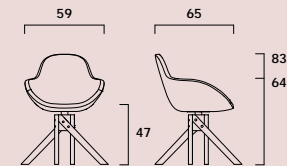

Darling 4
Swivel armchair
FG 356.04

Dindi

Sedia imbottita in poliuretano espanso ignifugo e rivestita in cuoio. Struttura in acciaio, schienale flessibile con anima in acciaio armonico. / Chair padded with flame-retardant polyurethane foam and upholstered in saddle leather. Steel frame, flexible back with spring steel core.

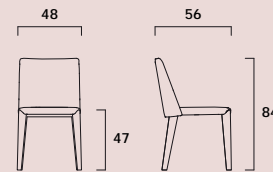

Dindi
Side chair
FG 448.00

Doa

Seduta con scocca in multistrato imbottita in poliuretano espanso ignifugo e rivestita in pelle. Gambe e struttura in legno massello di frassino. Disponibile con o senza braccioli. / Chair with plywood shell padded with flame-retardant polyurethane foam and upholstered in leather. Legs and frame in solid ash wood. Available with or without armrests.

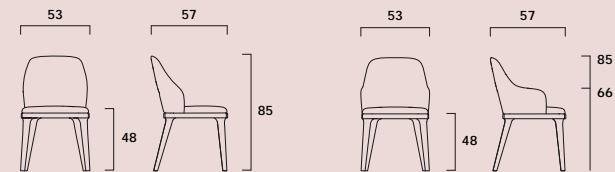

Doa
Side chair
FG 464.03

Doa P
Armchair
FG 464.02

Ele

Sedia con scocca in multistrato leggermente imbottita e rivestita in cuoio. Gambe in acciaio rivestite in cuoio. / Chair with lightly padded plywood shell and steel legs, fully upholstered in saddle leather.

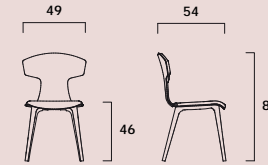

Ele
Side chair
FG 457.00

Elf

Famiglia di sedute imbottite in poliuretano espanso, interamente rivestite in pelle o tessuto. Struttura in acciaio con schienale flessibile. Disponibile con schienale alto o basso, con e senza braccioli. / Collection of chairs padded with polyurethane foam and fully upholstered in leather or fabric. Steel frame with flexible back. Available with high or low back, with or without armrests.

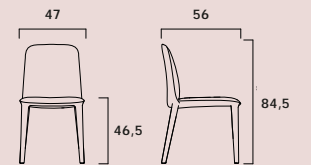

Elf
Side chair
FG 497.00

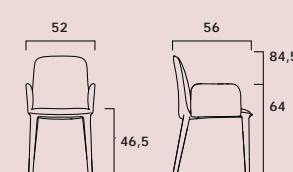

Elf P
Armchair
FG 497.01

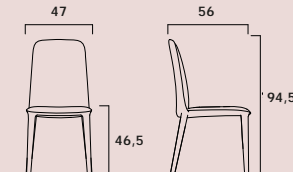

Elf H
Side chair
FG 497.02

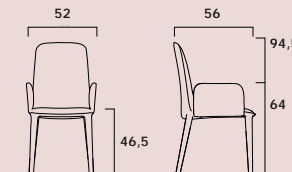

Elf HP
Armchair
FG 497.03

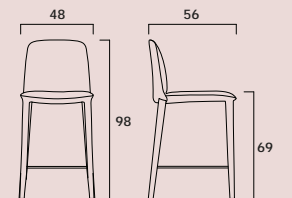

Elf C
Counter stool
FG 497.10

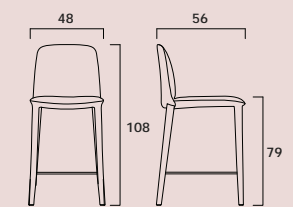

Elf B
bar stool
FG 497.11

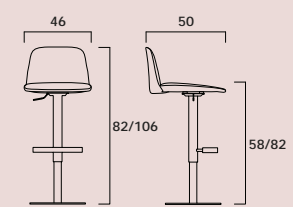

Elf GP
Height-adjustable stool
FG 497.12

Fizzy

Sgabello regolabile con seduta imbottita e rivestita in pelle o tessuto. Struttura in metallo cromo lucido. Schienale in metallo cromo lucido a o in pelle cucito a mano. / Height-adjustable stool with padded seat upholstered in leather or fabric. Polished chrome base. Metal backrest available chrome plated, or with hand-stitched leather insert.

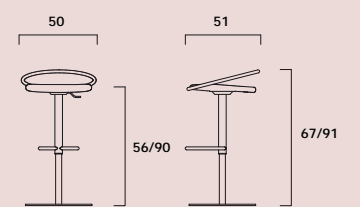

Fizzy metal backrest
Height-adjustable stool
FG 458.00

Fizzy

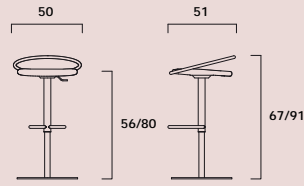

Fizzy leather backrest
Height-adjustable stool
FG 458.01

Heta

Poltrona con struttura in faggio. Seduta, schienale e braccioli autoportanti in cuoio pieno fiore. Cuscini di seduta, poggiatesta e poggiaresi in gommapiuma e ovatta rivestiti in pelle. Pouf con struttura in faggio e seduta autoportante in cuoio pieno fiore con cuscino in piuma d'oca rivestito in pelle. /

Armchair with beech wood frame. Self supporting full grain leather seat, back and armrests. Seat, headrest and lumbar support cushions in foam and wadding, upholstered in leather. Pouf with beech wood frame and self-supporting seat in full grain leather with goose down cushion, upholstered in leather.

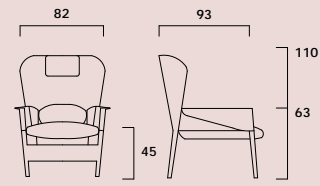

Heta bergere
Lounge armchair
FG 426.00

Kati

Famiglia di sedute leggermente imbottite e rivestite in pelle o tessuto. Scocca in poliuretano schiumato a freddo. Gambe in acciaio cromato o laccato. / Collection of lightly padded chairs upholstered in leather or fabric. Cold-moulded polyurethane shell. Chrome plated or painted steel legs.

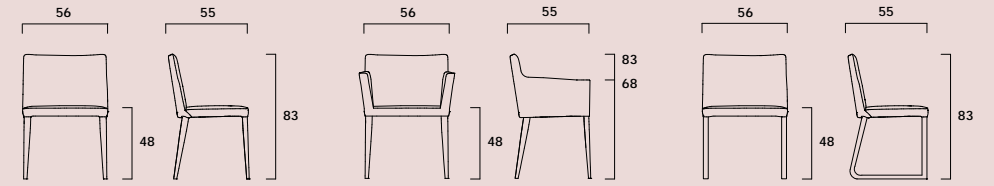

Kati
Side chair
FG 414.00

Kati P
Armchair
FG 415.00

Kati Z
Side chair
FG 414.02

Hollow

Poltrona lounge interamente imbottita e rivestita in pelle o tessuto. Struttura in metallo rivestita in poliuretano espanso ignifugo. Disponibile anche base con ritorno girevole. / Fully padded lounge chair, upholstered in leather or fabric. Metal frame and flame-retardant polyurethane foam. Swivel base also available with automatic return.

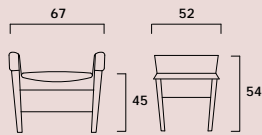

Heta pouf
Pouf
FG 426.01

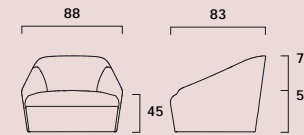

Hollow
Lounge armchair
FG 482.00

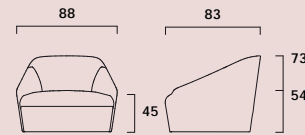

Hollow
Swivel lounge armchair
FG 482.01

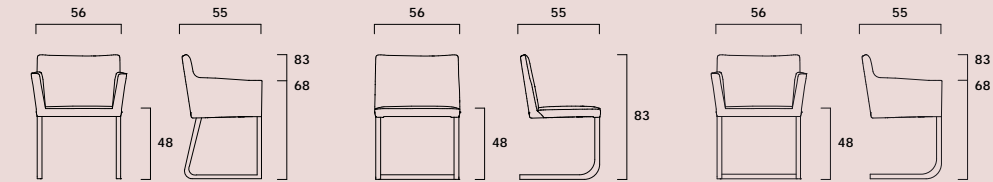

Kati PZ
Armchair
FG 415.02

Kati Q
Cantilever chair
FG 414.04

Kati PQ
Cantilever armchair
FG 415.04

Iki

Famiglia di sedute con sedile e schienale leggermente imbottiti e rivestiti in cuoio, pelle o tessuto. Telaio in metallo verniciato nero, gambe in frassino. Disponibile con e senza braccioli. / Collection of chairs with lightly padded seat and back, upholstered in leather, saddle leather or fabric. Black metal frame, ash wood legs. Available with or without armrests.

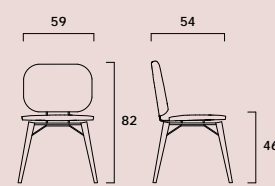

Iki W
Side chair
FG 333.05

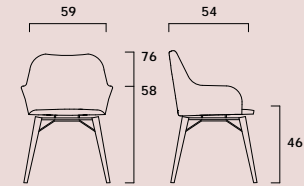

Iki PW
Armchair
FG 333.06

Latina

Famiglia di sedute leggermente imbottite e interamente rivestite in cuoio. Struttura in acciaio, schienale flessibile con anima in acciaio armonico. Disponibile con schienale alto o basso, con e senza braccioli. Lo sgabello è disponibile con altezza fissa o regolabile con seduta imbottita e rivestita in cuoio e struttura in metallo cromo lucido, satinato o nero.

Collection of lightly padded chairs and stools, fully upholstered in saddle leather. Steel frame, flexible back with spring steel core. Available with high or low back, with or without armrests. Height-adjustable stool with padded seat, upholstered in saddle leather on a polished chrome, matt chrome or black painted base.

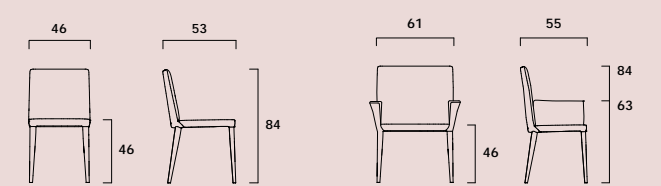

Latina
Side chair
FG 260.00

Latina P
Armchair
FG 262.01

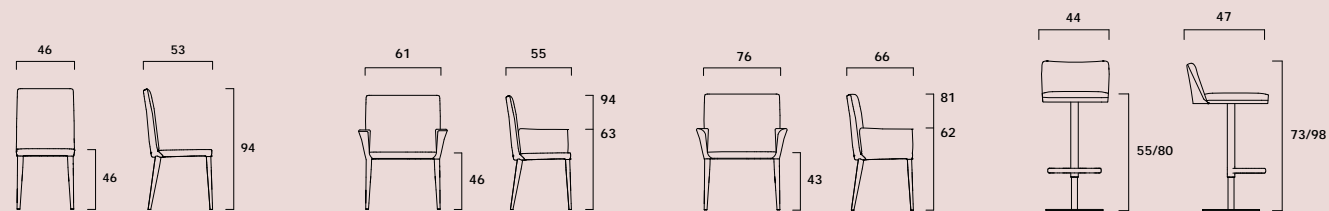

Latina H
Side chair
FG 261.00

Latina HP
Armchair
FG 262.00

Latina L
Lounge armchair
FG 285.00

Latina GP
Height-adjustable stool
FG 265.00

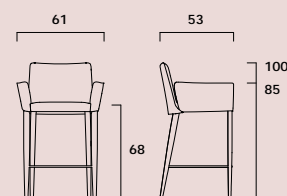

Latina CP
Stool
FG 265.04

Lilly

Famiglia di sedute leggermente imbottite e rivestite interamente in cuoio o pelle. Struttura in acciaio. Disponibile con schienale alto o basso. / *Collection of lightly padded chairs, fully upholstered in leather or saddle leather. Steel frame. Available with high or low back.*

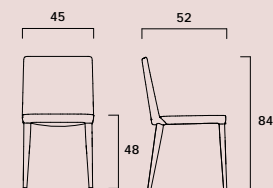

Lilly
Side chair
FG 408.00

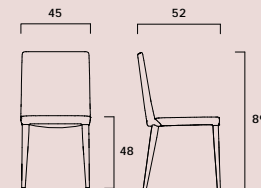

Lilly H
Side chair
FG 408.01

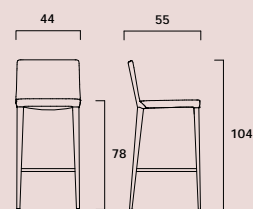

Lilly B
Bar stool
FG 408.03

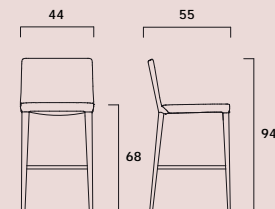

Lilly C
Counter stool
FG 408.02

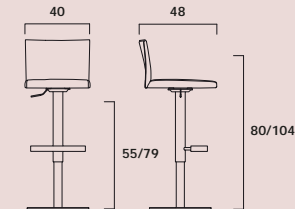

Lilly GP
Height-adjustable stool
FG 408.04

Linda

Sedia imbottita interamente rivestita in pelle o tessuto. Struttura in acciaio, schienale flessibile con anima in acciaio. / *Padded chair, fully upholstered in leather or fabric. Steel frame, flexible back with steel core.*

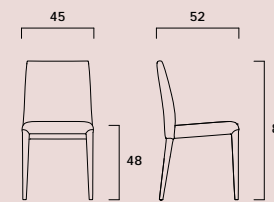

Linda
Side chair
FG 413.00

Lyo

Sedia con struttura tubolare in metallo cromo lucido, schienale e seduta in cuoio doppiato autoportante. / *Chair with polished chrome tubular steel structure, back and seat in self-supporting doubled saddle leather.*

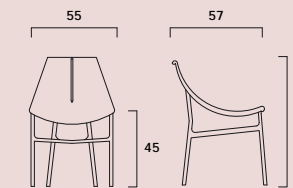

Lyo
Side chair
FG 352.00

Maio

Pouf imbottito in poliuretano espanso ignifugo e rivestito in pelle cucita al vivo. / *Pouf padded with flame-retardant polyurethane foam and upholstered in leather with raw cut edges.*

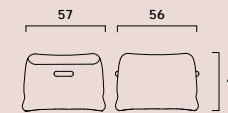

Maio
Pouf
FG 421.00

Mea

Famiglia di poltrone rivestite in pelle o tessuto con scocca in poliuretano schiumato a freddo. Disponibile con schienale alto o basso. Base girevole in alluminio lucido disponibile a 4 razze o a 5 razze con ruote. Modello con 5 razze e ruote disponibile con meccanismo a gas per la regolazione dell'altezza e meccanismo basculante.

Collection of armchairs upholstered in leather or fabric with cold-moulded polyurethane shell. Available with high or low back. Swivel base in polished aluminium available with 4 or 5 rays with casters. Model with 5 star base and casters available with gas lift mechanism for height adjustment and tilt adjustment.

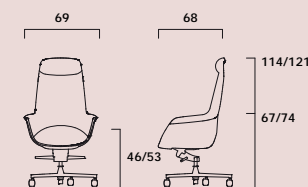

Mea H AR
Armchair with casters
FG 461.00

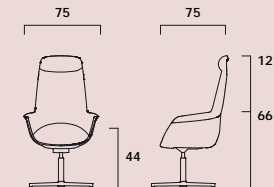

Mea H C
Armchair
FG 461.05

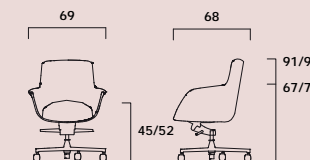

Mea AR
Armchair with casters
FG 462.00

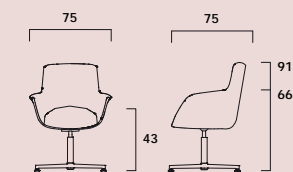

Mea C
Armchair
FG 462.05

Nisida

Famiglia di sedute con struttura in alluminio leggermente imbottite e interamente rivestite in cuoio. Disponibile con e senza braccioli. / *Collection of chairs with aluminium frame, lightly padded and fully upholstered in saddle leather. Available with or without armrests.*

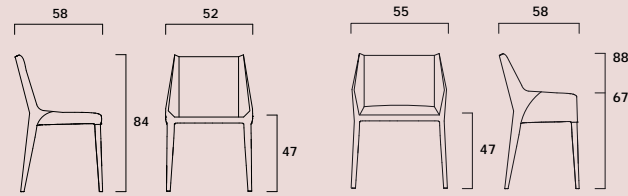

Nisida
Side chair
FG 342.00

Nisida P
Armchair
FG 342.01

Olimpia

Famiglia di sedute con struttura in tubolare d'acciaio verniciato o cromato e scocca imbottita e rivestita in pelle o tessuto. Disponibile con e senza braccioli. Schienale con dettaglio bottoni metallici. / *Collection of chairs with a tubular frame in painted steel or chrome and padded body upholstered in leather or fabric. Available with or without armrests. Back with metal button details.*

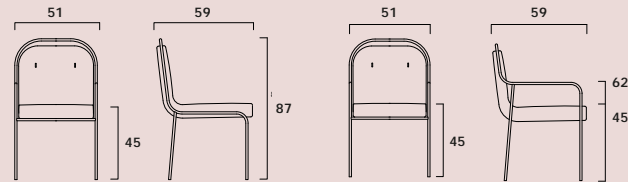

Olimpia
Side chair
FG 501.00

Olimpia P
Armchair
FG 501.01

Ponza

Seduta imbottita in poliuretano espanso ignifugo e rivestita in pelle o tessuto. Gambe in legno di frassino verniciate a poro aperto. Sgabello disponibile con altezza regolabile con seduta imbottita e rivestita in pelle o tessuto e struttura in metallo cromo lucido o verniciato nero.

Chair padded with flame-retardant polyurethane foam and upholstered in leather or fabric. Legs in open-pore lacquered ash wood. Height-adjustable stool with padded seat, upholstered in leather or fabric on a polished chrome plated or black painted.

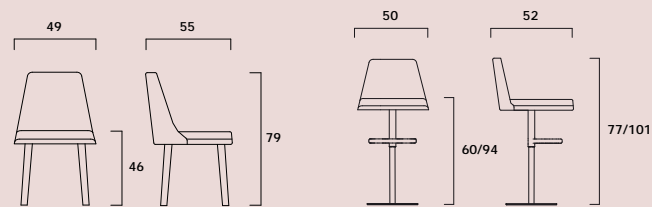

Ponza
Side chair
FG 405.00

Ponza GP
Height-adjustable stool
FG 405.07

Public

Famiglia di sedute interamente imbottite in poliuretano espanso ignifugo e rivestite in pelle o tessuto. Struttura in legno. Puntali disponibili in acciaio verniciato. / *Collection of chairs fully padded with flame-retardant polyurethane foam and upholstered in leather or fabric. Wooden frame. End caps available in painted steel.*

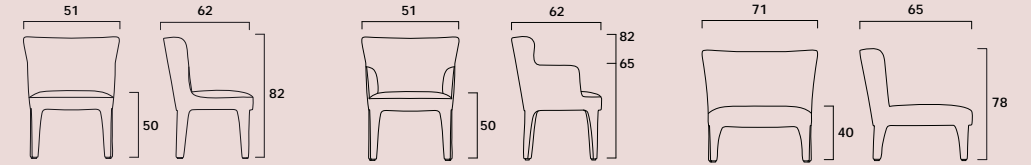

Public
Side chair
FG506.00

Public P
Armchair
FG506.01

Public L
Lounge armchair
FG506.02

Riviera

Poltrona lounge con struttura in tubolare d'acciaio verniciato o cromato, seduta e schienale in cuoio. Cuscini sfoderabili, imbottiti, rivestiti in pelle o tessuto. / *Lounge armchair with tubular frame in chrome plated or painted steel, seat and back in saddle leather. Removable cushions, padded and upholstered in leather or fabric.*

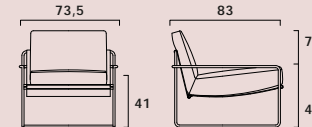

Riviera
Lounge armchair
FG 499.00

Sahrai

Poltrona lounge con seduta e schienale imbottiti in poliuretano espanso ignifugo e rivestiti in pelle o tessuto. Struttura e braccioli in acciaio verniciato con dettagli in pelle o tessuto. Pouf con seduta imbottita e rivestita in pelle o tessuto. / *Lounge armchair with padded flame-retardant polyurethane foam seat and back, upholstered in leather or fabric. Lacquered steel frame and armrests with leather or fabric details. Pouf with padded seat upholstered in leather or fabric.*

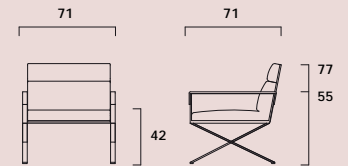

Sahrai L
Lounge armchair
FG 471.00

Sofy

Poltroncina con scocca in multistrato imbottita in poliuretano espanso ignifugo e rivestita in pelle o tessuto. Gambe in frassino. / *Armchair with plywood shell padded with flame-retardant polyurethane foam and upholstered in leather or fabric. Ash wood legs.*

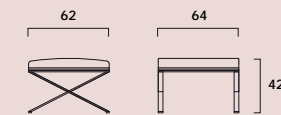

Sahrai Pouf
Pouf
FG 471.01

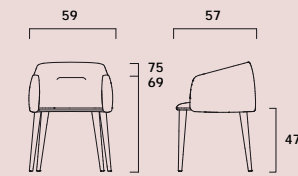

Sofy
Armchair
FG 446.00

Square

Famiglia di sedute con scocca leggermente imbottita e rivestita in cuoio, in pelle o tessuto. Cuscini in poliuretano sagomato rivestiti in pelle o tessuto. Gambe in tubo di acciaio verniciato, puntali in alluminio spazzolato. / *Collection of armchairs and stools with lightly padded shell, upholstered in leather, saddle leather or fabric. Moulded polyurethane seat cushions, upholstered in leather or fabric. Painted tubular steel legs with brushed aluminium tips.*

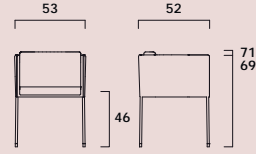

Square (mono-material)
Armchair
FG 465.20

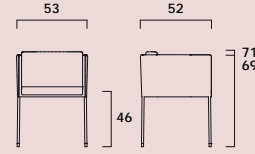

Square (bi-material)
Armchair
FG 465.00

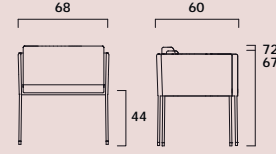

Square L (mono-material)
Lounge armchair
FG 465.21

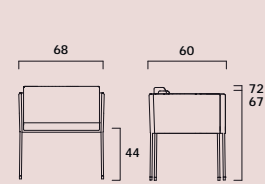

Square L (bi-material)
Lounge armchair
FG 465.01

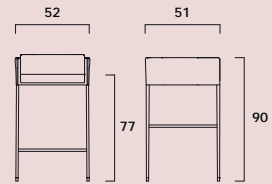

Square B (mono-material)
Bar stool
FG 465.23

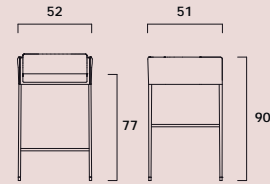

Square B (bi-material)
Bar stool
FG 465.03

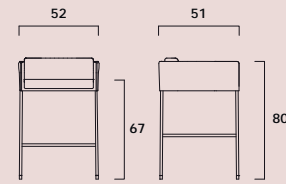

Square C (mono-material)
Counter stool
FG 465.22

Winnie

Poltrona lounge con struttura in metallo leggermente imbottita e rivestita in pelle o tessuto. Cuscini di seduta e schienale imbottiti in piuma ecologica e rivestiti in pelle o tessuto. Piedini in ottone brunito o verniciati neri. / *Lounge armchair with lightly padded metal frame upholstered in leather or fabric. Seat and back cushions filled with organic down and upholstered in leather or fabric. Burnished brass or black painted feet.*

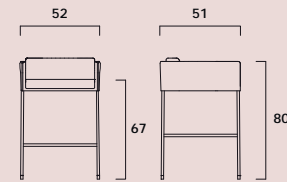

Square C (bi-material)
Counter stool
FG 465.02

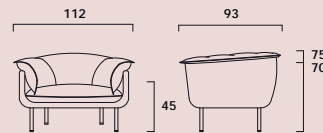

Winnie
Lounge armchair
FG 483.00

Accent tables →

Arita

Tavolino fronte divano con struttura in acciaio verniciato colore nero e terminali in ottone con effetto spazzolato. Top disponibile in legno noce impiallacciato con bordo laccato bordeaux o vetro float stampato millerighe.

Coffee table with black painted steel structure and brass end-caps with brushed effect. Top available in walnut veneer with burgundy lacquered edge or striped float glass.

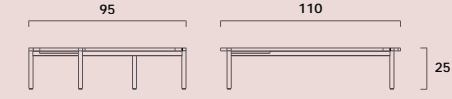

Arita CT
Coffee table
FG 520.00

Bak

Set di tavolini fronte e fianco divano con struttura in acciaio verniciato spazzolato con inserti pelle. Piano in particelle di legno rivestito con tranciato in legno di noce, disponibile in versione tonda o quadrata. / *Collection of accent tables with brushed lacquered steel frame and leather inserts. Walnut veneer particleboard top, available round or square.*

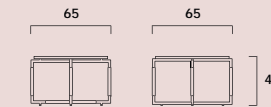

Bak CT
Side table
FG 442.01

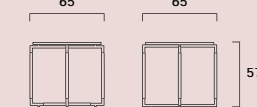

Bak CT H
Side table
FG 442.02

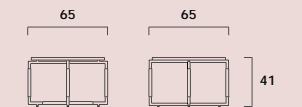

Bak CT O
Side table
FG 442.03

Comb

Tavolini fronte e fianco divano con struttura in tondino di metallo, disponibile in finitura ottone spazzolato o verniciato nero. Piano in mdf laccato. / *Collection of accent tables with metal rod frame, available in brushed brass or black painted finish. Top in lacquered MDF.*

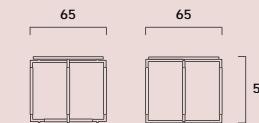

Bak CT HO
Side table
FG 442.04

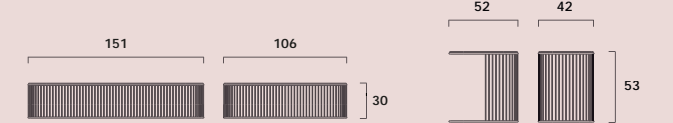

Comb 100
Coffee table
FG 487.01

Comb 40
Side table
FG 487.02

Motif

Set di tavolini con struttura in acciaio verniciato, ripiano in cuoio intarsiato. / *Set of accent tables with a steel frame and inlaid saddle-leather top.*

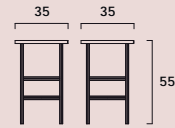

Motif 35
Side table
FG 509.02

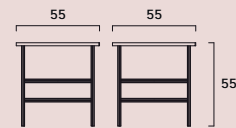

Motif 55
Side table
FG 509.00

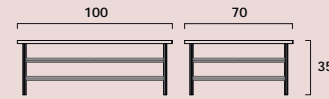

Motif 100
Coffee table
FG 509.01

Sahrai

Tavolino con struttura in acciaio verniciato e piano in mdf verniciato con finitura manuale in composito di cemento. / *Coffee table with painted steel frame and top in lacquered MDF hand-finished in cement composite.*

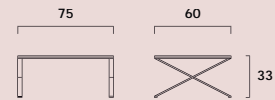

Sahrai CT
Coffee table
FG 471.02

Square

Set di tavolini fronte e fianco divano con struttura in tubo d'acciaio verniciato e puntali in alluminio o ottone spazzolato. Piano in mdf verniciato con finitura manuale in composito di cemento o in marmi di collezione. / *Set of accent tables made of lacquered tubular steel structure with brushed solid aluminium or brass tips. Top in lacquered MDF hand-finished in cement composite or in a choice of marbles from our collection.*

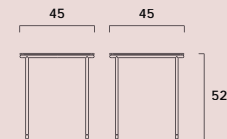

Square 52
Side table
FG 465.52

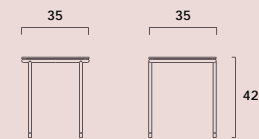

Square 42
Side table
FG 465.53

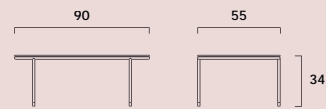

Square 34
Coffee table
FG 465.50

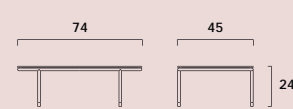

Square 24
Coffee table
FG 465.51

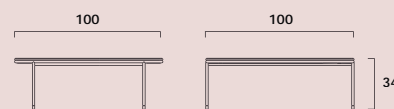

Square 100
Coffee table
FG 465.54

Square

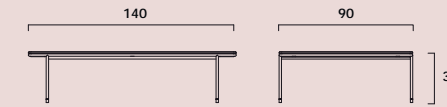

Square 140
Coffee table
FG 465.56

Viae

Set di tavolini disponibile in versione da 3 e 5 piani. Struttura in tondino metallico in finitura ottone spazzolato o verniciato nero, piani interamente rivestiti in cuoio. / *Set of accent tables available in 3 and 5 top versions. Rod structure with brushed brass or black painted finish, tops fully covered in saddle leather.*

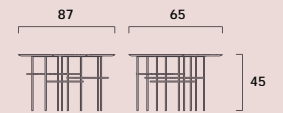

Viae 3
Coffee table
FG 484.01

Sofas →

Gast

Collezione di divani con struttura in legno multistrato imbottita in poliuretano espanso a quote differenziate. Cuscini di seduta e schienale in poliuretano espanso e memory foam con rivestimento in trapuntino. Rivestimento in pelle o tessuto. Piedini in materiale termoplastico nero a scomparsa. / *Collection of sofas with a plywood structure padded with polyurethane foam of different densities. Seat and back cushions in polyurethane and memory foam with quilt cover. Upholstered in leather or fabric. Hidden glides in black thermoplastic material.*

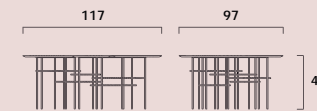

Viae 5
Coffee table
FG 484.00

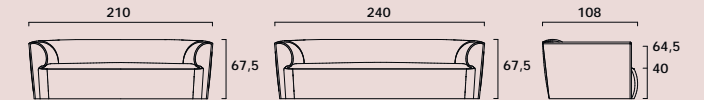

Gast 210
Sofa
FG 521.00

Gast 240
Sofa
FG 521.01

Hudson

Day bed con struttura in massello di frassino. Gambe in metallo verniciato spazzolato. Cuscino di seduta imbottito in poliuretano espanso ignifugo rivestito in pelle con impunture matelassé. Cuscino poggiatesta in poliuretano sagomato rivestito in pelle. /

Day bed with solid ash wood frame. Brushed painted metal legs. Cushion padded with flame-retardant polyurethane foam and upholstered in leather with matelassé finish. Headrest in moulded polyurethane, upholstered in leather.

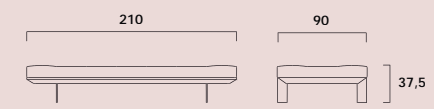

Hudson
Day bed
FG 477.00

Tutti i divani Otis hanno altezza 75 cm / All Otis sofas are 75 cm height

Otis

Collezione di divani chiusi ed elementi componibili. Struttura in metallo imbottita in poliuretano espanso a quote differenziate. Cuscini di seduta rivestiti con trapuntino in piuma d'oca con inserto centrale in poliuretano espanso. Rivestimenti in pelle o tessuto. Gambe in acciaio.

Collection of fixed sofas and modular elements. Metal frame covered in polyurethane foam of different densities. Goose-down quilted lining of the seat cushions with a polyurethane core. Upholstered in leather or fabric. Steel legs.

Composition 1
510.00
510.20+510.21

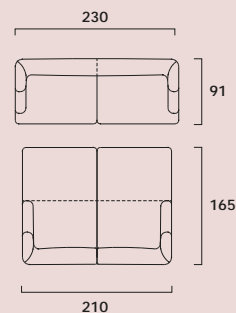

Composition 2
510.16 + 510.17
510.01

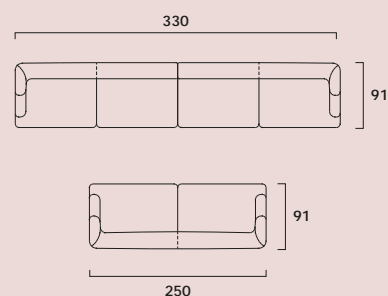

Composition 3
510.16 + 510.21
510.17 + 510.20

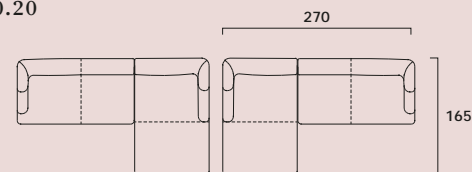

H45-60-75
Fg 510.00 - Sofa

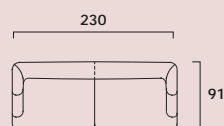

H45-60-75
Fg 510.01 - Sofa

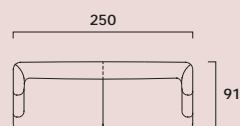

H45-60-75
Fg 510.16 -
Left end section

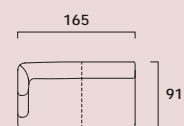

H45-60-75
Fg 510.17 -
Right end section

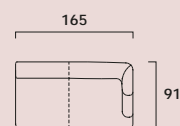

H45-60-75
Fg 510.20 -
Left chaise longue
section

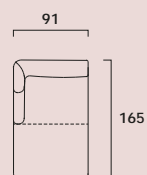

H45-60-75
Fg 510.21 -
Right chaise longue
section

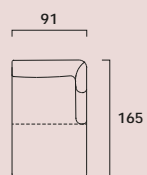

Cushions
(A) AC 990.00 Cushion
(B) AC 990.01 Cushion
(C) AC 990.02 Cushion

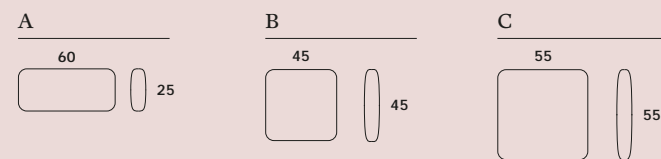

Public

Divanetto interamente imbottito in poliuretano espanso ignifugo e rivestito in pelle o tessuto. Struttura in legno. Puntali disponibili in acciaio verniciato. / Small sofa fully padded with flame-retardant polyurethane foam and upholstered in leather or fabric. Wooden frame. End caps available in painted steel.

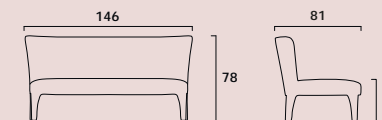

Public
Sofa
FG 506.03

Winnie Sofa

Collezione di divani con struttura in metallo leggermente imbottita e rivestita in pelle o tessuto. Cuscini di seduta e schienale imbottiti in piuma ecologica e rivestiti in pelle o tessuto. Piedini in ottone brunito o verniciati neri. / Collection of sofas with lightly padded metal frame covered in leather or fabric. Seat and back cushions filled with eco-friendly down and upholstered in leather or fabric. Feet in brushed or painted black brass.

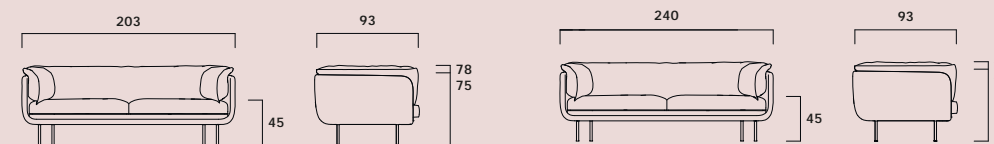

Winnie Sofa 200
Sofa
FG 483.01

Winnie Sofa 240
Sofa
FG 483.02

Tutti i divani Wilton hanno altezza 78 cm / All Wilton sofas are 78 cm high

Wilton

Collezione di divani chiusi ed elementi componibili. Struttura leggermente imbottita. Cuscini di seduta, braccioli e schienale rivestiti con trapuntino in piuma d'oca con inserto in poliuretano espanso. Rivestimento in cuoio (solo struttura) pelle o tessuto. Piedini in acciaio verniciato.
/ Collection of fixed sofas and modular elements. Lightly padded body. Goose-down quilted lining of seat cushions, armrests and backrest with a polyurethane core. Upholstered in saddle leather (only body), leather or fabric. Steel feet in brushed brass or brushed dark grey finish.

Composition 1
M 511.04+511.22 B 511.05+511.23
M 511.06+511.20 B 511.07+511.21

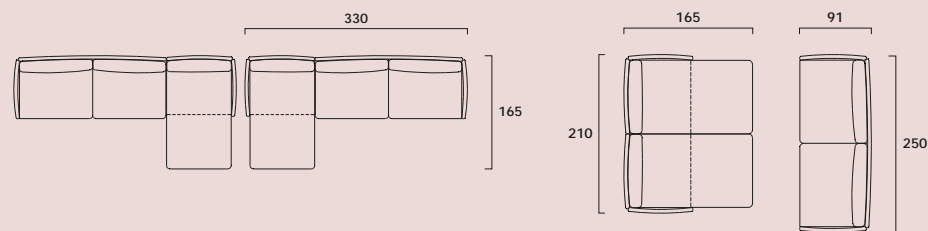

Composition 2
M 511.02 B 511.03
M 511.20+511.22 B 511.21+511.23

Composition 3
M 511.04+511.10 B 511.05+511.11
M 511.06+511.08 B 511.07+511.09

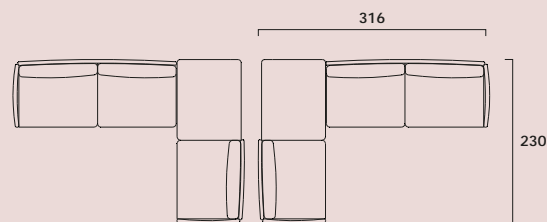

Composition 4 *
M 511.04+511.12+511.14 B 511.05+511.13+511.15
M 511.06+511.14+511.12 B 511.07+511.15+511.13

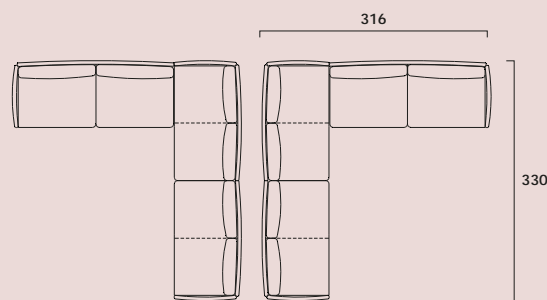

Composition 5 *
M 511.16+511.18+511.14 B 511.17+511.19+511.15
M 511.16+511.18+511.12 B 511.17+511.19+511.13

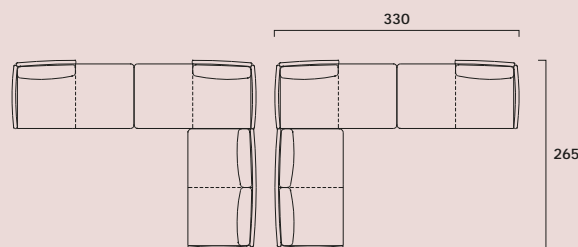

Composition 6
M 511.12+511.22 B 511.13+511.23
M 511.14+511.20 B 511.15+511.21

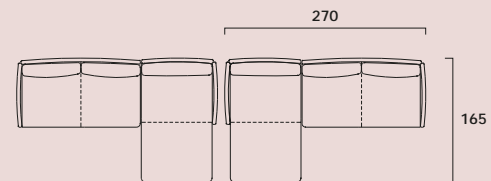

Composition 7
M 511.02+511.10 B 511.03+511.11
M 511.02+511.08 B 511.03+511.09

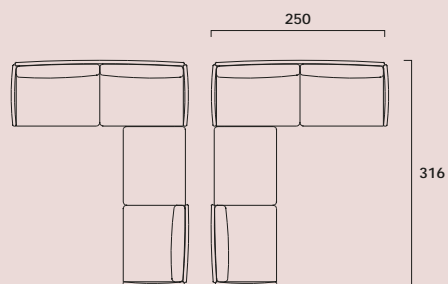

Composition 8 *
M 511.04+511.04 B 511.05+511.05
M 511.06+511.06 B 511.07+511.07

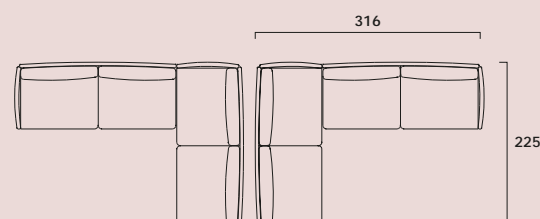

Composition 9
M 511.04+511.00 B 511.05+511.01
M 511.06+511.00 B 511.07+511.01

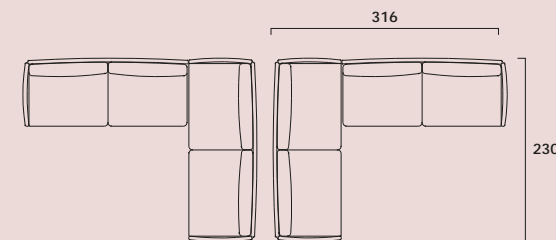

H40-62-78
FG 511.00 - Section M
FG 511.01 - Section B

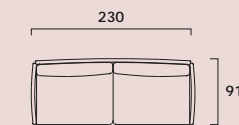

H40-62-78
FG 511.02 - Section M
FG 511.03 - Section B

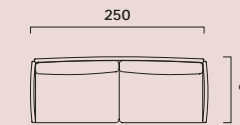

H40-62-78
FG 511.04 - Left end corner section M
FG 511.05 - Left end corner section B

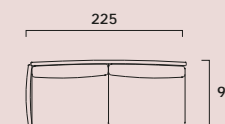

H40-62-78
FG 511.06 - Right end corner section M
FG 511.07 - Right end corner section B

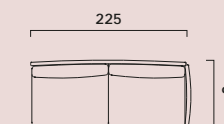

H40-62-78
FG 511.08 - Left ottoman section B
FG 511.09 - Left ottoman section B

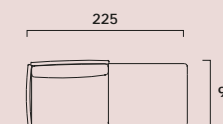

H40-62-78
FG 511.10 - Right ottoman section M
FG 511.11 - Right ottoman section B

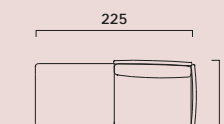

H40-62-78
FG 511.12 - Left end corner section M
FG 511.13 - Left end corner section B

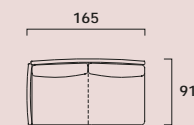

H40-62-78
FG 511.14 - Right end corner section M
FG 511.15 - Right end corner section B

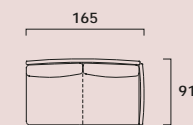

H40-62-78
FG 511.16 - Left ottoman section M
FG 511.17 - Left ottoman section B

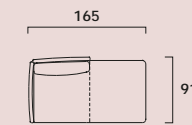

H40-62-78
FG 511.18 - Right ottoman section monomaterial
FG 511.19 - Right ottoman section bimaterial

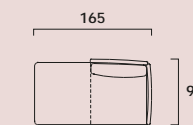

H40-62-78
FG 511.20 - Left chaise longue - section M
FG 511.21 - Left chaise longue - section B

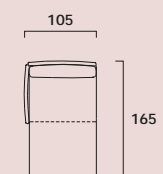

H40-62-78
FG 511.22 - Right chaise longue - section M
FG 511.23 - Right chaise longue - section B

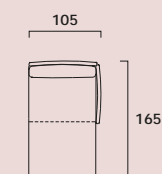

Cushions
(A) AC 990.00 Cushion
(B) AC 990.01 Cushion
(C) AC 990.02 Cushion

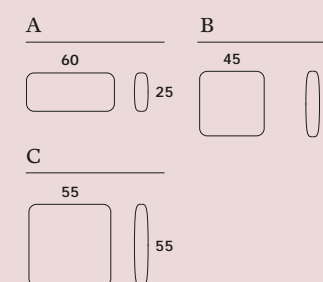

Structural Cushions
(D) AC 511.99 Armrest structural cushion
(E) AC 511.98 Backrest structural cushion

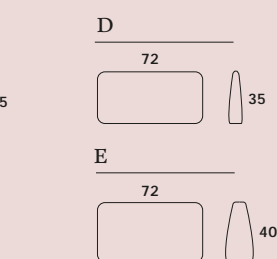

Tables →

Arita

Scrittoio e consolle con struttura in acciaio verniciato nero e terminali in ottone con effetto spazzolato. Top disponibile in legno noce impiallacciato con bordo laccato bordeaux o vetro float stampato millerighe. / Desk and console with black painted steel structure and brass end-caps with brushed effect. Top available in walnut veneer with burgundy lacquered edge or striped float glass.

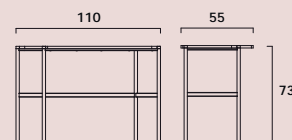

Arita Desk
Desk
FG 520.01

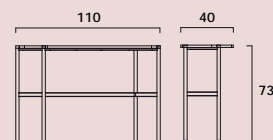

Arita Console
Console
FG 520.02

Argor

Tavolo con struttura in acciaio e pannelli rivestiti in cuoio. Piano in cristallo retroverniciato. / Table with steel frame and panels covered in saddle leather. Top in back-painted glass.

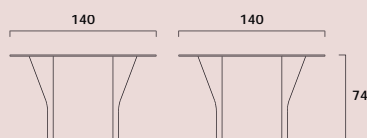

Argor 140
Table
FG 404.00

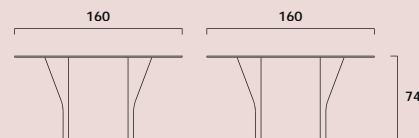

Argor 160
Table
FG 404.03

Artù

Tavolo tondo con base rivestita in pelle e dettagli in metallo con finitura in ottone spazzolato. Top in marmo. Su richiesta, vassoio girevole in marmo. / Round table with a base covered in leather and metal details with a brushed brass finish. Marble top. Marble lazy Susan available upon request.

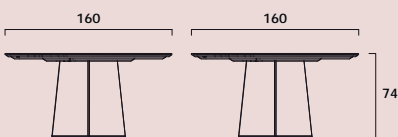

Artù 160
Table
FG 494.00

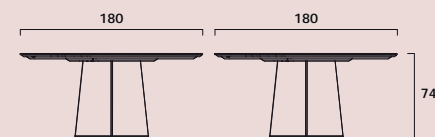

Artù 180
Table
FG 494.01

Artù

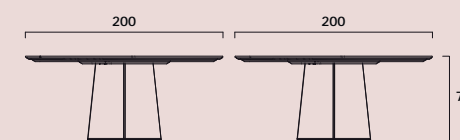

Artù 200
Table
FG 494.02

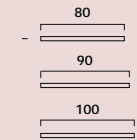

Lazy Susan
AC 494.01
AC 494.02
AC 494.03

Atelier

Tavolo con base in acciaio verniciato spazzolato. Piano in mdf verniciato con finitura manuale in composito di cemento. / Table with brushed painted steel base. Top in lacquered MDF hand-finished in cement composite.

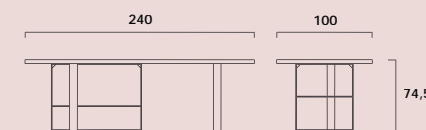

Atelier 240
Table
FG 468.00

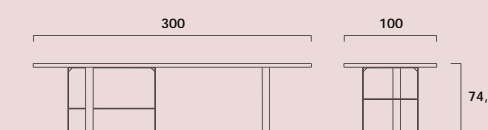

Atelier 300
Table
FG 468.01

Bak table

Tavolo con struttura in acciaio verniciato spazzolato con inserti in pelle. Piano in particelle di legno rivestito con tranciato in legno di noce. / Table with painted brushed steel frame with leather inserts. Walnut veneered particleboard top.

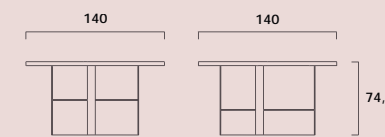

Atelier 140
Table
FG 468.50

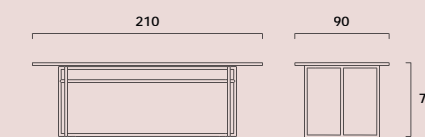

Bak table
Table
FG 442.00

Bridge

Tavolo con base in alluminio, piano in vetro temperato extrachiaro o fumé o in marmi di collezione. / *Table with aluminium base, top in extra-clear or smoky tempered glass or marble from our collection.*

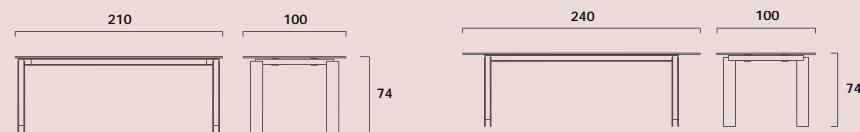

Bridge 210
Table
FG 453.01

Bridge 240
Table
FG 453.00

Dante

Scrivania o tavolo interamente rivestito in cuoio. Piano con impunture. / *Desk or table fully upholstered in saddle leather. Top with stitching.*

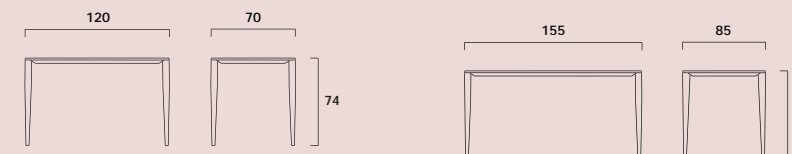

Dante 120
Desk
FG 366.01

Dante 150
Desk
FG 366.00

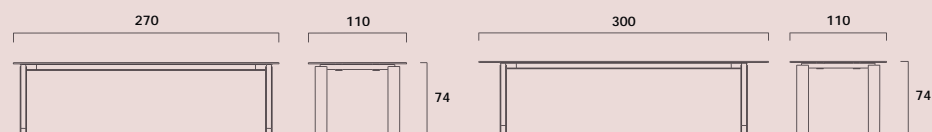

Bridge 270
Table
FG 453.02

Bridge 300
Table
FG 453.03

Doni

Tavolo con base in acciaio verniciato, piano nei marmi di collezione. Disponibile in 3 altezze, lounge, dining e bar. / *Table with painted steel base, top in a choice of marble from our collection. Available in 3 heights, lounge, dining and bar.*

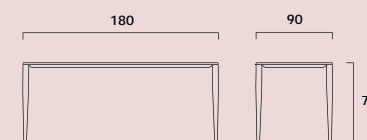

Dante 180
Desk/Table
FG 366.02

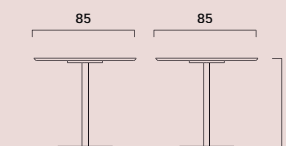

Doni 73
Table
FG 485.00

Caribou

Tavolo con struttura in massello di noce e dettagli in metallo verniciato ottone brunito. Piano composto da particelle di legno rivestito con tranciato in legno di noce. / *Table with solid walnut structure and burnished-brass lacquered metal details. Walnut veneered particleboard top.*

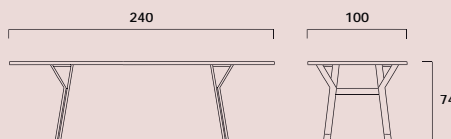

Caribou 240
Table
FG 480.01

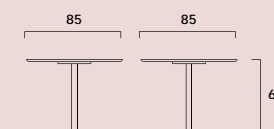

Doni 62
Lounge table
FG 485.01

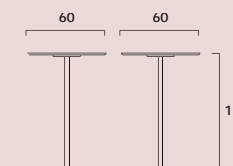

Doni 110
Bar table
FG 485.02

Paipu

Tavolo tondo e ovale con base in tubi d'acciaio curvato e verniciati grigio scuro spazzolato. Top in marmo o vetro retroverniciato nero. / Round and oval table with a base in curved steel tubes and finished in brushed dark grey. Marble or back-painted glass top.

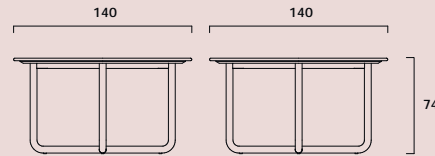

Paipu 140
Table
FG 522.01

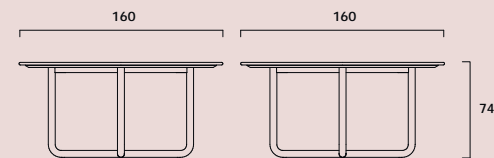

Paipu 160
Table
FG 522.00

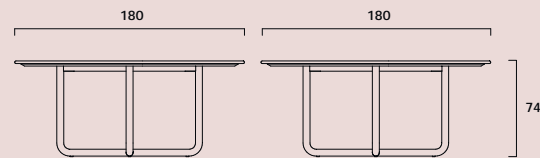

Paipu 180
Table
FG 522.02

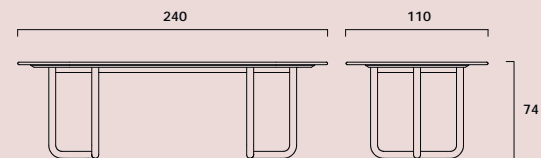

Paipu 240
Table
FG 522.11

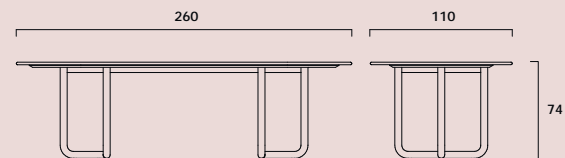

Paipu 260
Table
FG 522.10

Twain

Scrivania con struttura in acciaio verniciato spazzolato e doppio piano rivestito in pelle. / Desk with painted brushed steel frame and double tier top upholstered in leather.

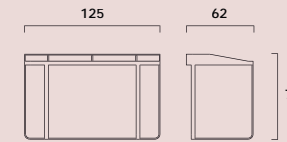

Twain
Desk
FG 444.00

Complements →

Bak Bench

Panca con struttura in acciaio verniciato spazzolato con inserti in pelle. Imbottita in poliuretano espanso ignifugo rivestita in pelle. / Bench with painted brushed steel frame and leather inserts. Seat padded with flame-retardant polyurethane foam upholstered in leather.

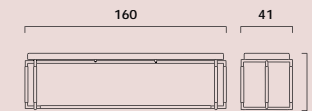

Bak bench
Bench
FG 441.01

Bak Bookcase

Libreria con struttura in acciaio verniciato spazzolato con inserti in pelle, ripiani in MDF rivestiti con tranciato in legno di noce. / Bookcase with painted brushed steel frame and leather inserts, walnut veneered MDF shelves.

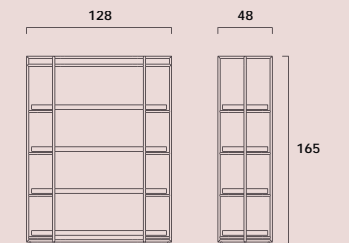

Bak bookcase
Bookcase
FG 440.10

Bak Valet Stand

Appendiabiti con struttura in acciaio verniciato spazzolato con inserti in pelle, ripiani tondi in acciaio leggermente imbottiti e parzialmente rivestiti in pelle. Disponibile con o senza specchio. / Valet stand featuring a painted brushed steel frame with leather inserts, lightly padded round steel shelves partially upholstered in leather. Available with or without mirror.

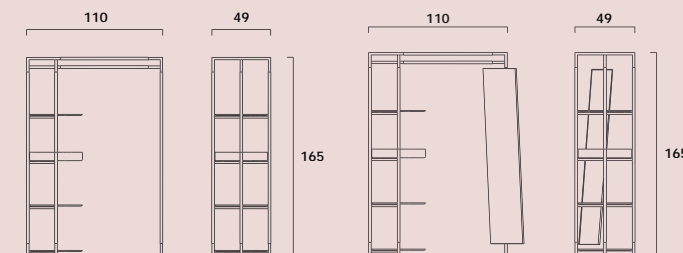

Bak valet stand
Valet stand
FG 440.00

Bak mirror
Valet stand
FG 440.01

Morgans

Libreria a parete con struttura in alluminio anodizzato, mensole rivestite in cuoio. / *Anodised aluminium bookcase with saddle-leather upholstered shelves.*

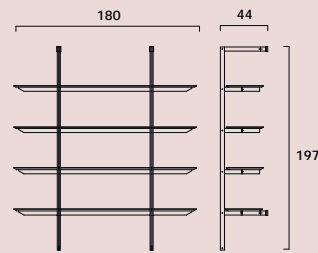

Morgans
Bookcase
FG 507.00

Privé

Famiglia di mobili contenitori, madia e credenza. Struttura composta da pannelli di particelle di legno rivestiti con tranciato in legno di noce. Mensole interne in vetro extrachiario temperato. Basamento in tubolare d'acciaio verniciato con puntali in alluminio spazzolato. Madia disponibile con e senza cassetti. Top in pelle.

Collection of storage units, cup board and side board. Frame made of walnut veneered particleboard panels. Inside shelves in extra-clear tempered glass. Base in painted tubular steel with brushed aluminium tips. Side board available with or without drawers. Leather top.

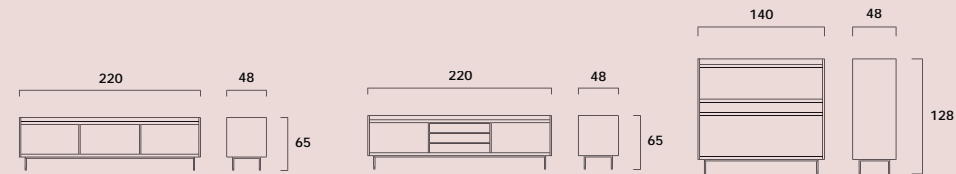

Privé A
Side board
FG 478.01

Privé B
Side board with drawers
FG 478.00

Privé C
Cup board
FG 478.10

Otto

Letto composto da struttura e testata in legno multistrato imbottito e rivestito in pelle. Piedini in metallo verniciato in colore nero e puntali con finitura ottone spazzolato. / *Bed composed of a frame and a headboard in plywood, padded and upholstered in leather. Feet in black varnished metal and tips finished in brushed brass.*

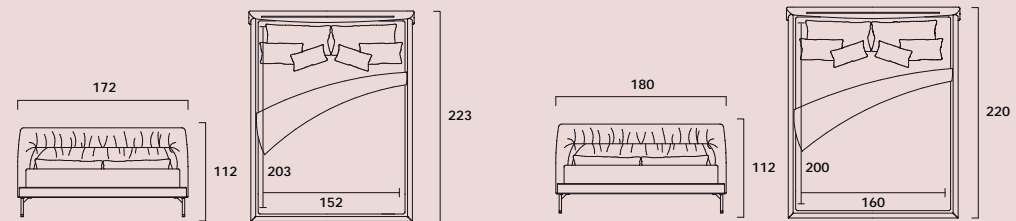

Otto Queen
Queen bed
FG 517.00
Mattress 1.52 × 2.03 m
Mattress 60 × 80 in

Otto 160
Bed
FG 517.04
Mattress 1.6 × 2 m

Otto

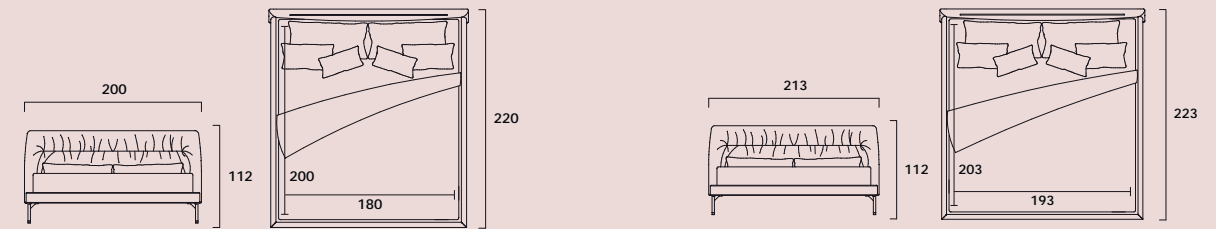

Otto 180
Bed
FG 517.05
Mattress 1.8 × 2 m

Otto King
King bed
FG 517.01
Mattress 1.93 × 2.03 m
Mattress 76 × 80 in

Viae

Servomuto con struttura in tondino metallico, finitura ottone spazzolato o verniciato nero. Servomuto con ripiani e appendiabiti rivestiti in cuoio. / *Valet stand with a metal rod frame with brushed brass or black painted finish, shelf and clothes stand upholstered in saddle leather.*

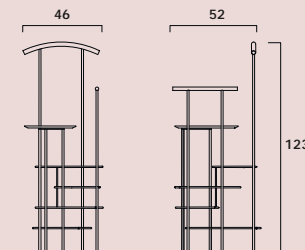

Viae Valet Stand
Valet stand
FG 484.50

Colophon. /Acknowledgements.

Company info

Frag Srl
Via dei Boschi 2
33040 Pradamano
Udine Italia
Tel. +39 0432 671375
frag@frag.it
www.frag.it

Credits

Art Direction
R+W

Concept and design
Samuele Savio /
Choice—Studio

Lay-out
Roberta Donatini /
Choice—Studio

Project coordination
Federica di Fonzo

Photos
Photographer
Gionata Xerra
Photo assistant
Leonardo Duggento

Stylist
Simona Silenzi Studio
Stylist Assistant
Gaia Marchesini

Photo retouching
Malvina Monteggia

Color separation
Luce srl

Print
OGM SpA

Settembre 2020

Thanks to

CC Tapis
Vano Alto
Oluce
ZPSTUDIO
Artemide
Bitossi Home
Ghidini 1961
Gumdesign
Hands on Design
Ichendorf Milano
Maddalena Selvini

The colours reproduced in the images, printed or in video, may differ from the actual colour of the material and should be regarded as a mere example. For a real comparison, we recommend using an original colour sample of the material.

Frag reserves the right to introduce any changes to its own models without prior notice. Color tones may vary from one dye lot to another.

© 2020 by Frag srl
All rights reserved



Frag
dal 1921

www.frag.it