

Collection News / 21

Frag
dal 1921

Collection News / 21

- 005 Abacus
- 009 Moodboard
Drawings
- 021 New
Products
- 023 Gast
- 039 Arita Family
- 049 Paipu
- 057 Twin
- 061 Otto
- 067 Quattro Family
- 073 Clubby CT
- 075 New
Materials
- 083 Technical
Data



Abacus (A—Z)



Sofas
→



Gast
FG 521
Shooting 23-37
Details 86-87
Also 46-47 68-69

Poufs
→



Quattro Pouf
FG 518.00
Shooting 67-71
Details 88
Also 24-25 62-63

Desks
→



Arita Console
FG 520.02
Shooting 39-47
Details 84
Also 58-59



Arita Desk
FG 520.01
Shooting 39-47
Details 84

Tables
→



Paipu
140 FG 522.01
160 FG 522.00
180 FG 522.02
Shooting 49-55
Details 85



Paipu
240 FG 522.11
260 FG 522.10
Shooting 49-55
Details 85

Occasional
Tables
→



Arita CT
FG 520.00
Shooting 39-47
Details 84
Also 26-27 30-31 32-33



Quattro CT 26
FG 518.52
Shooting 67-71
Details 88
Also 24-25 34-35



Quattro CT 55
FG 518.51
Shooting 67-71
Details 88
Also 24-25



Clubby CT
FG 493.50
Shooting 73
Details 84

Beds
→



Otto
Queen FG 517.00
King FG 517.01
180 FG 517.05
160 FG 517.04

Shooting 61-65
Details 89

Comple-
ments
→



Twin One
FG 524.00
Shooting 57-59
Details 89



Twin Duo
FG 524.10
Shooting 57-59
Details 89

Moodboard drawings:

(It) Un gioco di combinazioni ricercate per creare atmosfere diverse. Accostando le finiture in modo creativo e dosando i materiali come fossero "ingredienti", gli interni acquistano ogni volta un singolare sapore. I moodboard di Frag disegnano un'armonia contemporanea, dove le pelli e i cuoi guidano sapientemente la mescolanza di colori e materiali che nella moltitudine di abbinamenti possibili danno vita a paesaggi sempre nuovi.

(En) *A play of sophisticated combinations to create different atmospheres. By combining the finishes creatively and dosing the materials as if they were "ingredients", interiors acquire a unique taste each time. Fragmoodboards outline a contemporary harmony, where leathers and saddle leathers wisely dictate the mixture of colors and materials that, in the multitude of possible combinations, give life to ever new landscapes.*



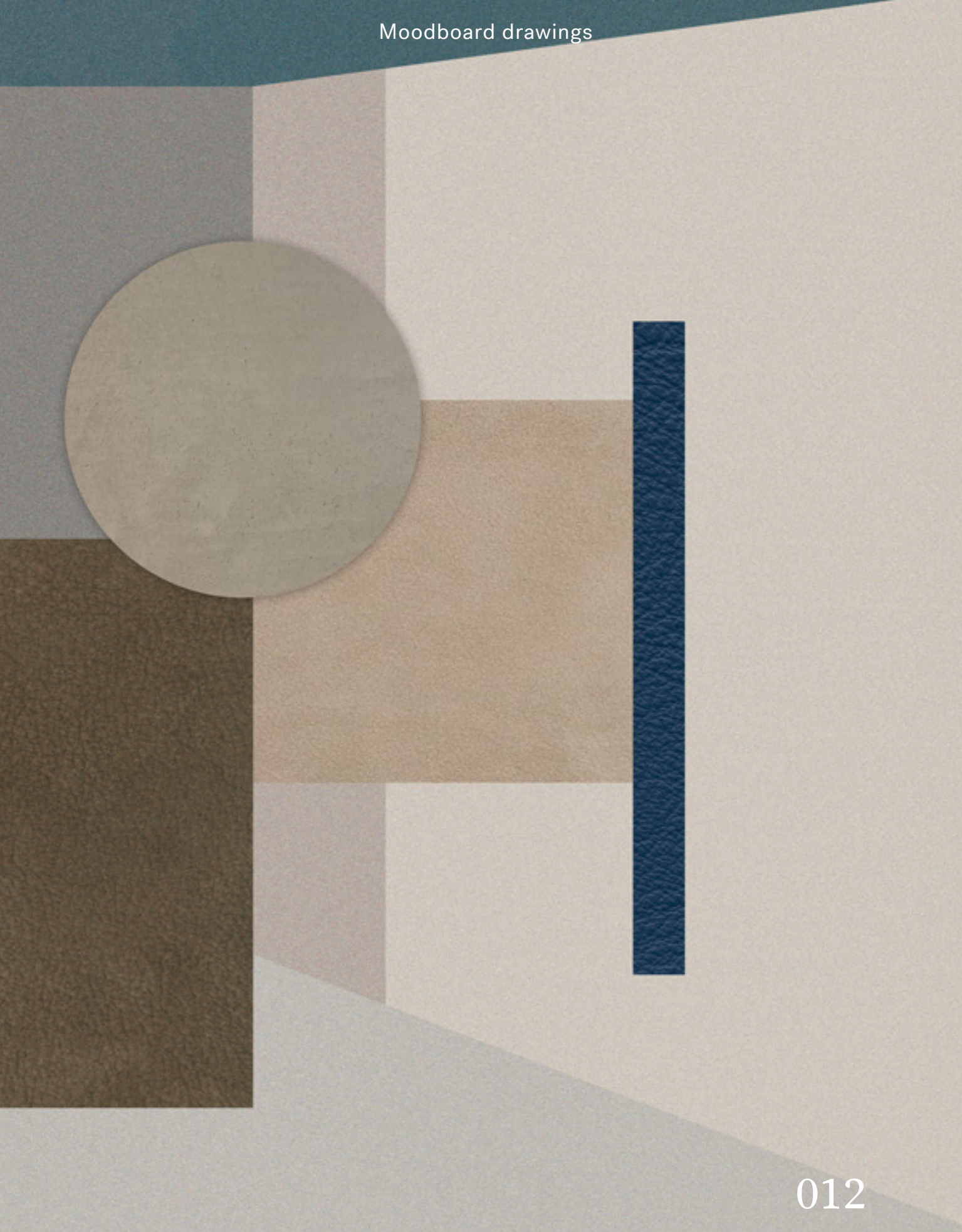

012



013

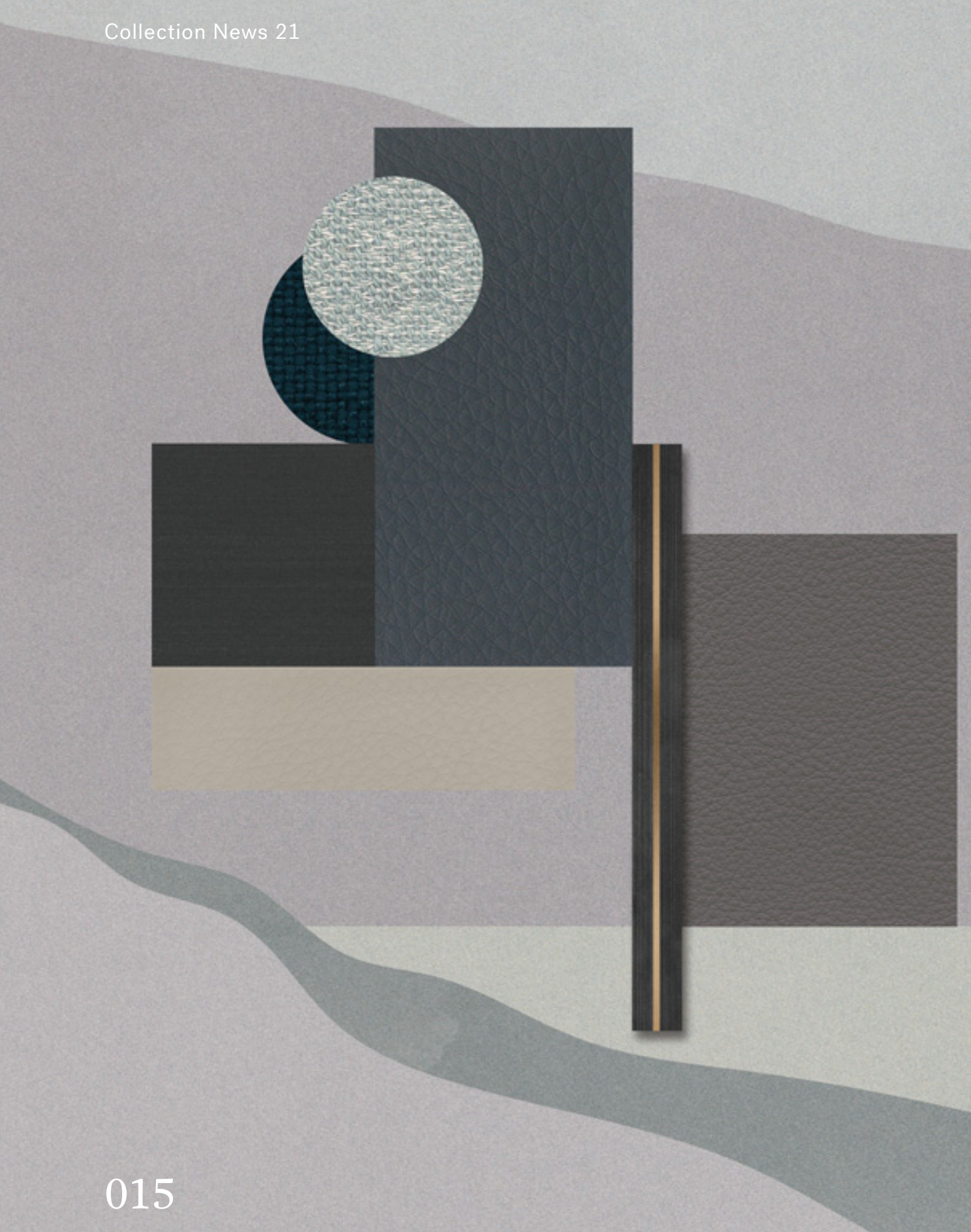



016

017

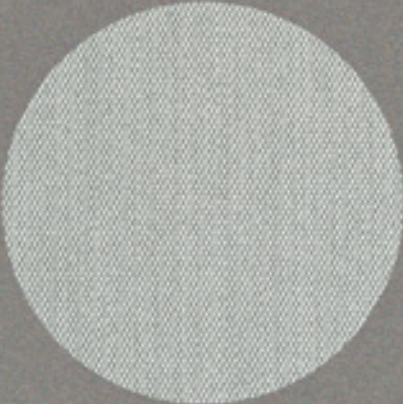

018

019

New Products:

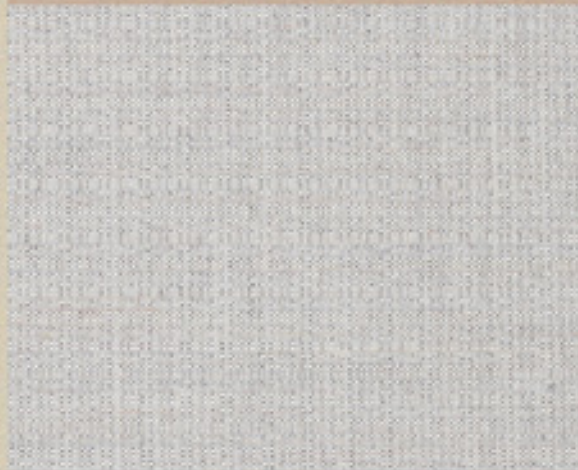



Model

design: Luis Arrivillaga

Gast,

(It) accogliente e protettivo, Gast è un divano modulare in cui convive un'anima d'ispirazione classica tipica dei divani dei primi del '900 mescolata con l'ironia degli imbottiti degli anni '60, reinterpretato in chiave contemporanea. La voluminosità importante delle parti imbottite interne è resa più leggera dal disegno netto e lineare della struttura contenitiva esterna, caratteristiche che lo rendono unico nel suo genere. Carattere distintivo della collezione sono le cuciture, studiate minuziosamente per enfatizzare il suo disegno e la sua morbidezza.

(En) welcoming and protective, Gast is a modular sofa in which a soul of classic inspiration, typical of the early XX century sofas, coexists with the irony of the '60s upholstered furniture, reinterpreted in a contemporary key. The substantial volume of the inner padded parts is made lighter by the clean and linear design of the outer containment structure, characteristics that make it unique in its kind. The distinctive trait of this collection of sofas is represented by the seams, accurately studied to emphasize its design and its softness.

→ Quattro CT 26 / FG 518.52
→ Gast Comp 2 / FG 521.10 + FG 521.13

→ Quattro CT 55 / FG 518.51
→ Quattro Pouf / FG 518.00





→ Arita CT / FG 520.00
→ Clabby Pouf / FG 493.10
→ Gast Comp. 4 / FG 521.10 + FG 521.14 + 521.30

026

027

→ Gast 210 / FG 521.00
→ Gast / FG 521.15 + 521.30



028



029



030

031



→ Riviera / FG 499.00
→ Gast Comp. 7 / FG 521.10 + FG 521.14 + FG 521.15 + FG 521.11
→ Arita CT / FG 520.00
→ Clubby Pouf / FG 493.10



→ Gast Comp. 3 / FG 521.11 + 521.20
→ Quattro CT 26 / FG 518.52



→ Gast / FG 521.11

036



037

Arita Family,



(It) collezione di tre elementi composta da scrittoio, consolle e tavolino, dal design minimale e al contempo ricca di dettagli. Il disegno pulito ed essenziale del sottile piano d'appoggio acquisisce ritmo nella sua forma insolita e inaspettata. La mancanza di simmetria sia nel piano che nelle gambe, i volumi sottratti negli angoli e la struttura di sostegno sporgente, fanno di Arita una collezione unica nel suo genere e perfetta per una ricercata progettazione d'interni.

(En) *collection of three elements composed of a desk, a consolle and a coffee table, with a minimalist design yet rich in detail. The clean and essential design of the thin table top acquires rhythm through its unusual and unexpected shape. The lack of symmetry in both the top and the legs, the subtracted volumes in the corners and the protruding supporting structure, make Arita a unique collection in its kind and perfect for a refined interior design project.*



040



→ Arita Desk / FG 520.01

041

→ Arita Consolle / FG 520.02



042



043



044



→ Arita CT / FG 520.00

045



→ Arita CT / FG 520.00
→ Gast comp. 4 / FG 521.10 + FG 521.14 + FG 521.30
→ Clubby Pouf / FG 493.10



Model

design: Dainelli Studio

Paipu,

(It) tavolo da pranzo disponibile in due varianti, tondo ed ovale, dall'evocativo sapore che richiama i diktat dell'architettura high-tech anni '70, dove tutti gli elementi impiantistici e strutturali venivano trasferiti sulle facciate e lasciati interamente a vista. I tubolari in acciaio curvato che compongono la base, regalano movimento e rigore al progetto, dialogando in armonico contrasto con la ricchezza del prezioso piano in marmo. Nella sua versione tonda il tavolo è sorretto da singola base con tubolari disposti a croce, mentre la versione ovale è sorretta da una doppia base con tubolari disposti a "T".

(En) *dining table available in two versions, round and oval, with an evocative taste that recalls the diktats of the high-tech architecture of the 70s, when all the system and structural elements were transferred to the facades and left entirely exposed. The curved steel tubes that make up the base confer movement and rigour to the project, in a dialogue of harmonic contrast with the richness of the precious marble top. In the round version the table is supported by a single base with tubes arranged in a cross, while the oval version is supported by a double base with tubes arranged in a "T" shape.*



→ Paipu 260 / FG 522.10
→ Olimpia / FG 501.00

050

051



→ Paipu 160 / FG 522.00
→ Paipu 260 / FG 522.10





054



→ Paipu 160 / FG 522.00
→ Nisida / FG 342.00

055

Twin,



(It) famiglia composta da due specchi con disegno e dimensioni differenti, definiti da forme geometriche semplici, circolari, ovali e rettangolari, che evocano un sapore di tradizione impresiosito e attualizzato da ricercate finiture. Reminiscenza dell'eleganza anni '50, questa collezione di specchi presenta una cornice in ottone fine ed elegante che sostiene lo specchio con leggerezza. La cornice è disegnata in modo che vi sia uno spazio tra il vetro dello specchio e la cornice, conferendo un'estetica aerea, leggera e al contempo raffinata.

(En) family composed of two mirrors of different designs and sizes that employ simple circular, oval and rectangular geometric shapes to embellish and update a traditional look with a sophisticated touch. This mirror collection has a stylishly delicate brass frame that offers graceful support to the mirrors and recalls the elegance of the 1950s. The frame design leaves space between itself and the mirror glass, creating a look of light and airy refinement.



→ Arita Consolle / FG 520.02
→ Twin One / FG 524.00

058

059



Otto,

(It) sospeso da terra e sorretto da una struttura dalle linee delicate, il letto Otto si distingue per il rivestimento totalmente in pelle e per il particolare disegno fluido e avvolgente della testata imbottita pensata per facilitare i momenti di lettura. Caratteri distintivi sono la sinuosa curva che raccorda testata e giroletto, e il segno netto orizzontale al centro della testata che raccoglie e arriccia la pelle del rivestimento accentuando il senso di comfort.

(En) *suspended from the ground and supported by a structure with delicate lines, the Otto bed stands out for its full leather upholstery and for the particular fluid and enveloping design of the padded headboard, conceived to ease the moments dedicated to reading. Distinctive features are the sinuous curve that connects the headboard to the bed frame, and the sharp horizontal stroke in the center of the headboard that gathers and wrinkles the leather of the upholstery, accentuating the sense of comfort.*



→ Quattro CT 55 / FG 518.81
→ Clubby Pouf / FG 493.10

→ Otto 180 / FG 517.05
→ Quattro Pouf / FG 518.00

062

063

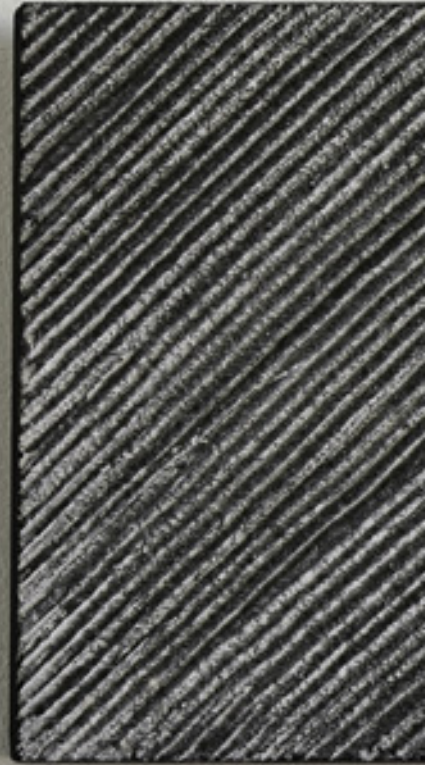

064



→ Otto 180 / FG 517.05

065



Quattro Family,

(It) un progetto di pouf e tavolini fatto di forme armoniche in cui il leitmotiv è rappresentato dal tubolare metallico curvato della base che dialoga in equilibrato contrasto con il cuscino di seduta e con i piani di appoggio. Quattro pouf è caratterizzato da una seduta generosa ed un'importante imbottitura a strati multipli che invita al relax. La seduta imbottita si rivela nel suo disegno come un cuscino decorativo sospeso nel nulla sorretto dalla leggera e minimale struttura in tubolare metallico curvato. Ad accompagnare il pouf troviamo Quattro occasional table, una serie di tavolini caratterizzati dalla stessa base in tondino metallico del pouf, su cui poggia un semplice ed elegante piano realizzato in marmo e metallo.

(En) *a coordinated range of poufs and accent tables whose leitmotif is represented by the curved metal tubing of the base, which dialogues in balanced contrast with the seat cushion and support surfaces. Quattro pouf features a generously padded multi-layer seat that invites relaxation. The design of the padded seat gives it the appearance of a decorative cushion suspended in thin air on a light and minimal supporting structure of curved metal tubing. To complement and enhance the pouf's personality, the two designers have also designed Quattro occasional table, a series of accent tables that feature the same tubular metal base as the pouf, supporting a simple and elegant top of marble and metal.*



→ Quattro CT 55 / FG 518.51
→ Clubby Pouf / FG 493.10

→ Gast 240 / FG 521.01
→ Quattro Pouf / FG 518.00
→ Quattro CT 26 / FG 518.52



→ Quattro CT 26 / FG 518.52
→ Quattro CT 55 / FG 518.51
→ Quattro Pouf / FG 518.00



Clubby CT,



(It) la famiglia Clubby, composta da club armchair e pouf ispirati alle poltroncine dei fumoir dei circoli parigini, si arricchisce con un tavolino dalle linee tondeggianti, leitmotiv di tutta la collezione. Rifinito da un moderno piano in mdf con finitura ottone spazzolato, le proporzioni e le forme di questo tavolino lo rendono particolarmente adatto agli spazi comuni e agli utilizzi più legati al mondo del contract.

(En) *the Clubby family, made up of club armchairs and poufs inspired by the armchairs of the fumoirs of the Parisian smokers circles, is enriched with a coffee table with rounded lines, the leitmotif of the entire collection. Finished with a modern MDF top with brushed brass finish, the proportions and shapes of this coffee table make it particularly suitable for public areas and contract settings.*

New Materials:

Nabuk / Nabuk / 31 Michelangelo



31-3401
Grigio Ferro
Steel Grey



31-3410
Marrone
Brown

Pelle / Leather / 07 Leonardo



07-226
Rinoceronte
Rhino



07-228
Bianco Ostrica
Oyster White



07-303
Perla
Pearl



07-452
Caramello
Caramel



07-741
Tramonto
Sunset

Pelle / Leather / 09 Raffaello



09-227
Grigio Argento
Silver Grey



09-405
Cannella
Cinnamon



09-620
Fungo
Mushroom

Cuoio / Saddle Leather / 02



02-204
Elefante
Elephant



02-264
Piuma
Feather Grey

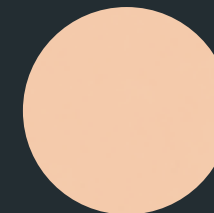

02-402
Naturale
Nude



02-461
Fieno
Hay



02-515
Cappuccino
Capuchin



02-600
Testa Di Moro
Dark Brown



02-808
Sottobosco
Undergrowth

Tessuti / Fabrics / 38 Venere

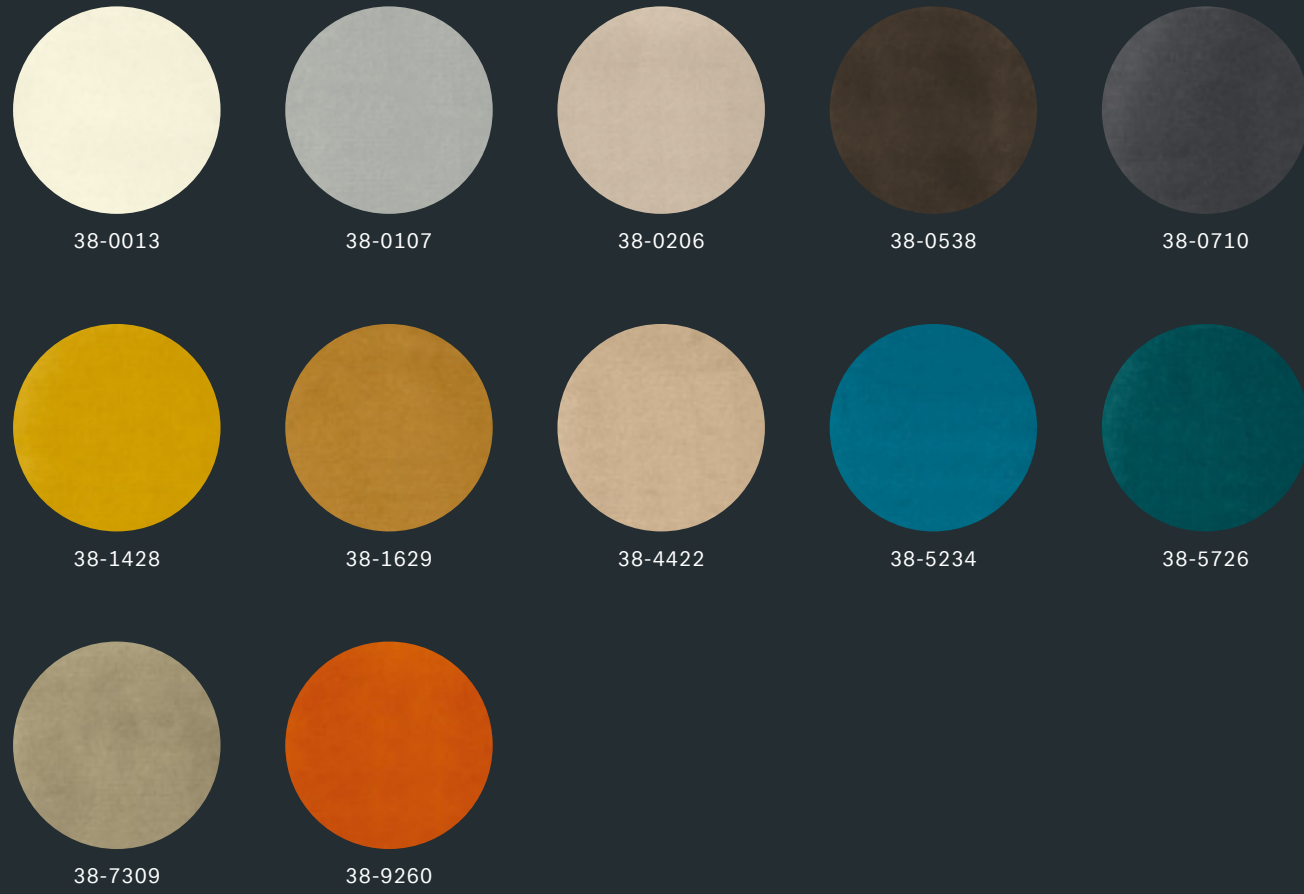

Tessuti / Fabrics / 60 Sirio

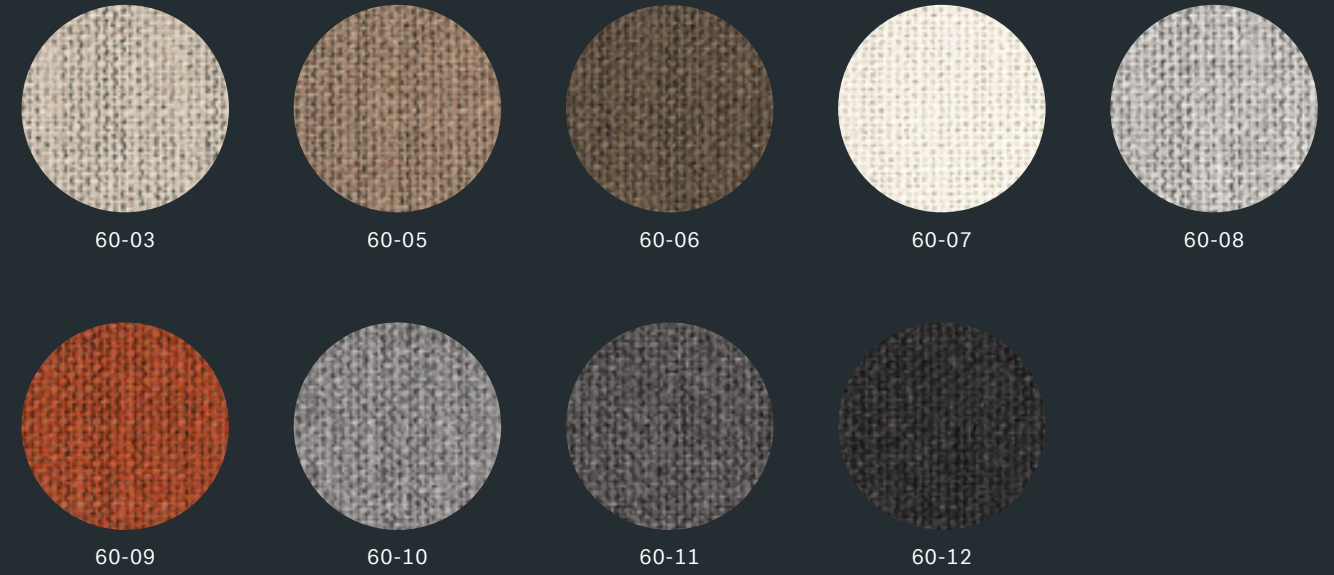

Tessuti / Fabrics / 61 Teddy

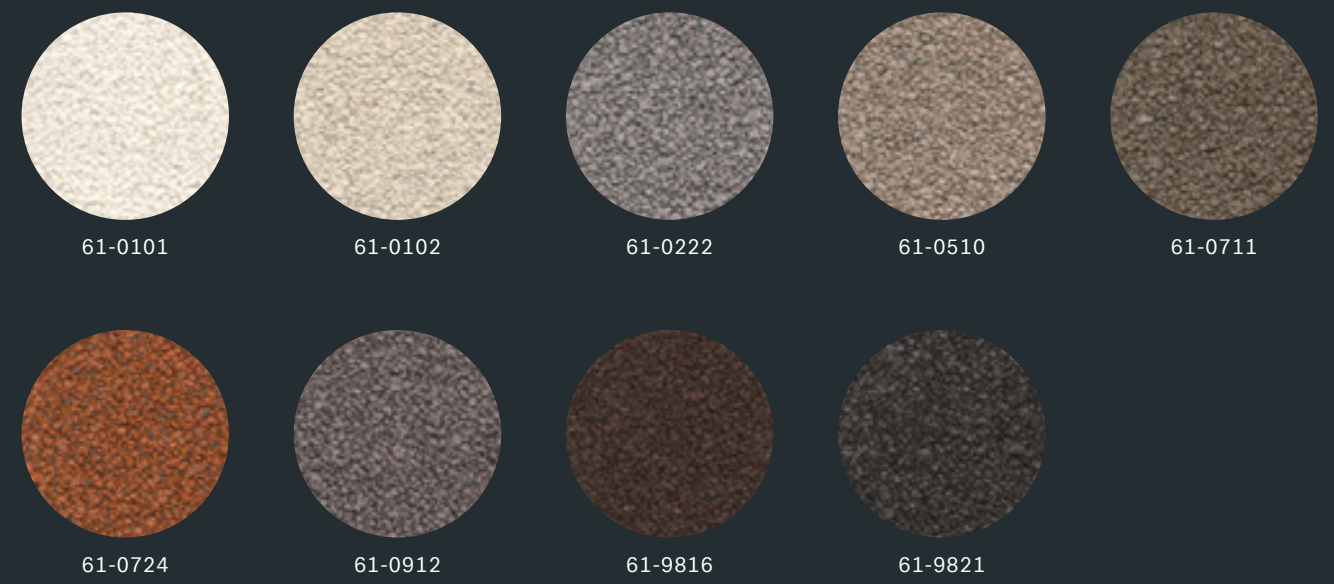

Tessuti / Fabrics / 62 Lira

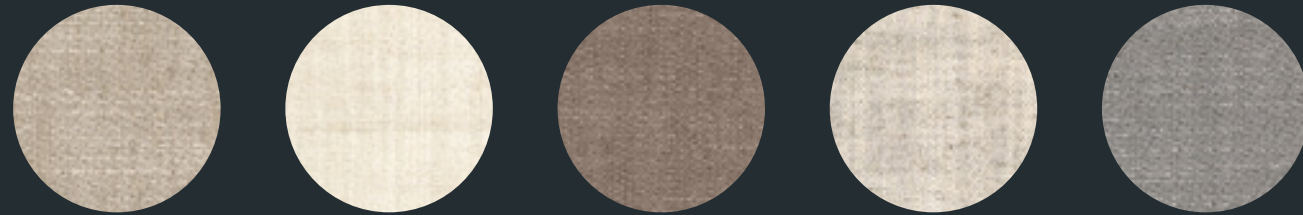

62-02 62-03 62-04 62-05 62-06



62-07 62-15 62-16

Tessuti / Fabrics / 63 Andromeda



63-002 63-003 63-011 63-014 63-020



63-022 63-028 63-031 63-100



Technical Data:

Arita CT

Tavolino fronte divano con struttura in acciaio verniciato colore nero e terminali in ottone con effetto spazzolato. Top disponibile in legno noce impiallacciato con bordo laccato bordeaux o vetro float stampato millerighe. / Coffee table with black painted steel structure and brass end-caps with brushed effect. Top available in walnut veneer wood with burgundy lacquered edge or striped float glass.

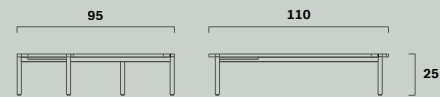

Arita CT
Coffee table
FG 520.00

Arita Desk + Consolle

Scrivania e consolle con struttura in acciaio verniciato colore nero e terminali in ottone con effetto spazzolato. Top disponibile in legno noce impiallacciato con bordo laccato bordeaux o vetro float stampato millerighe. / Desk and consolle with black painted steel structure and brass end-caps with brushed effect. Top available in walnut veneer with burgundy lacquered edge or striped float glass.

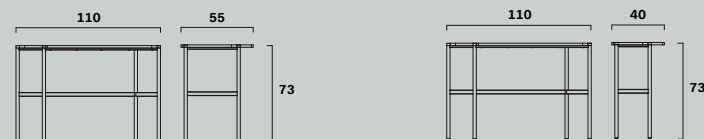

Arita Desk
Desk
FG 520.01

Arita Consolle
Consolle
FG 520.02

Clubby CT

Tavolino imbottito rivestito in pelle o tessuto. Top in mdf finitura ottone spazzolato. / Padded coffee table upholstered in leather or fabric. Mdf top finished in brushed brass.

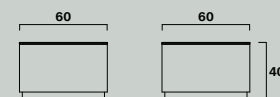

Clubby CT
Coffee table
FG 493.50

Paipu

Tavolo tondo o ovale con base in tubo d'acciaio curvato e verniciato grigio scuro spazzolato. Top in marmo o vetro retroverniciato nero. / Round or oval table with a base in curved steel tube and brushed dark grey finish. Marble or black back-painted glass top.

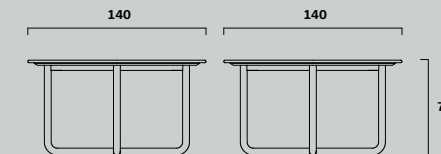

Paipu 140
Table
FG 522.01

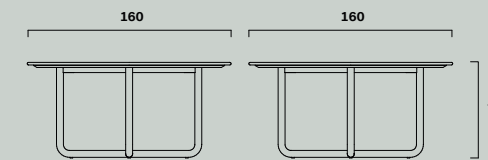

Paipu 160
Table
FG 522.00

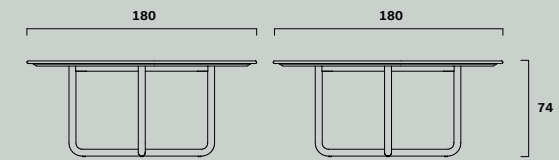

Paipu 180
Table
FG 522.02

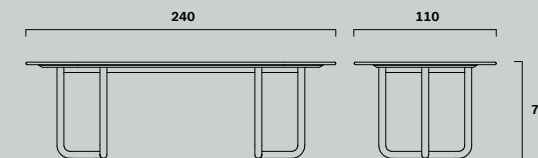

Paipu 240
Table
FG 522.11

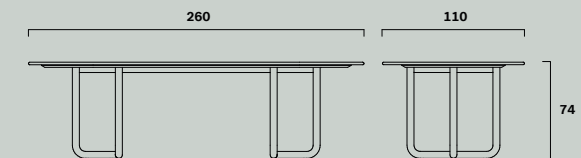

Paipu 260
Table
FG 522.10

Gast

Collezione di divani chiusi ed elementi componibili. Struttura in legno multistrato imbottita in poliuretano espanso a quote differenziate. Cuscini di seduta e schienale in poliuretano espanso e memory foam con rivestimento in trapuntino. Rivestimento in pelle o tessuto. Piedini in materiale termoplastico nero a scomparsa. / *Collection of fixed sofas and modular elements. Plywood structure padded with polyurethane foam of different densities. Seat and back cushions in polyurethane and memory foam with quilt cover. Upholstered in leather or fabric. Hidden glides in black thermoplastic material.*

Composition 1
FG 521.10 + FG 521.11

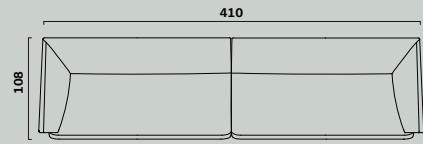

Composition 2
FG 521.12 + FG 521.11

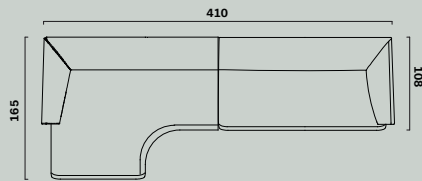

Composition 3
FG 521.10 + FG 521.21

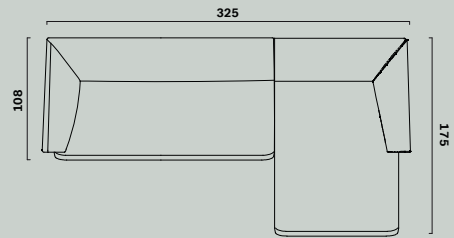

Composition 4
FG 521.10 + FG 521.14

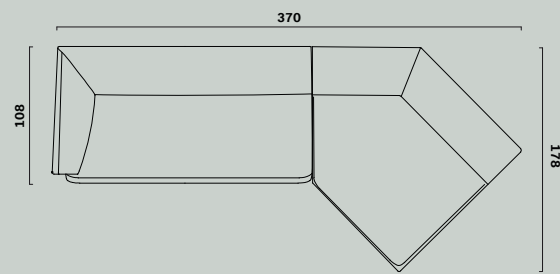

Composition 5 *
FG 521.10 + FG 521.14 + FG 521.15

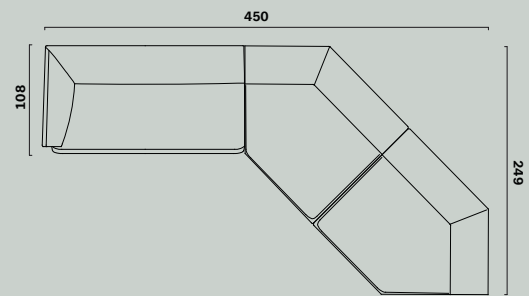

Composition 6
FG 521.30 + FG 521.15 + FG 521.13

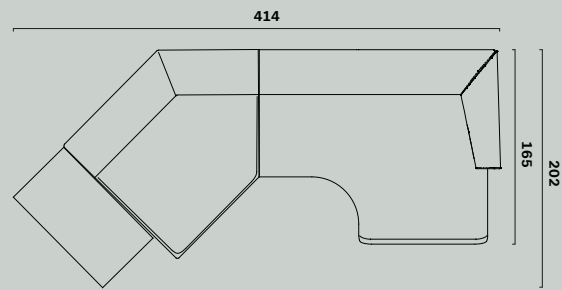

Composition 7
FG 521.10 + FG 521.14 + FG 521.15 +
FG 521.30 + FG 521.11

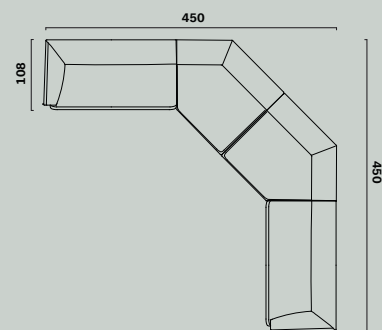

Gast Sofa 210
FG 521.00

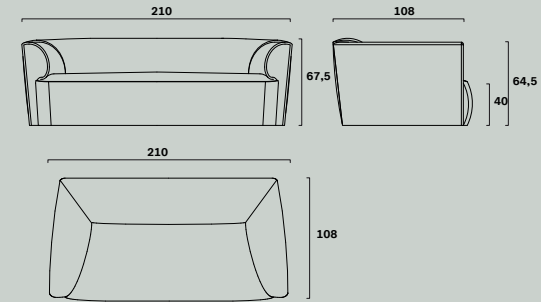

Gast Sofa 240
FG 521.01

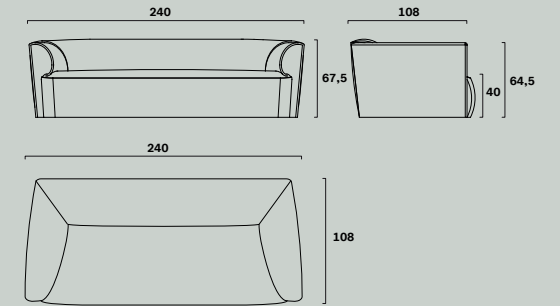

FG 521.10
Gast left
end corner

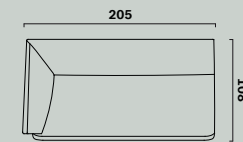

FG 521.11
Gast right
end corner

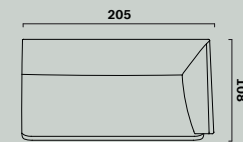

FG 521.12
Gast rounded
left end corner

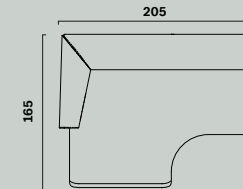

FG 521.13
Gast rounded
right end corner

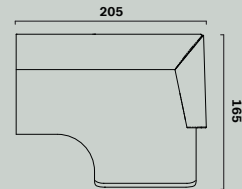

FG 521.14
Gast left lounge
pentagon corner

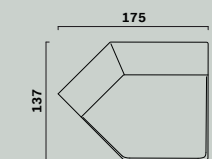

FG 521.15
Gast right lounge
pentagon corner

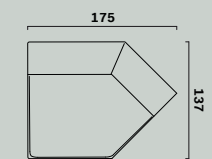

FG 521.20
Gast left
chaise longue

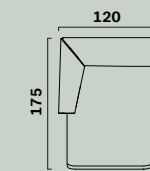

FG 521.21
Gast right
chaise longue

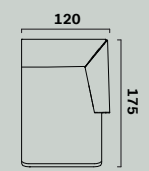

FG 521.30
Gast central element
(available for all compositions)

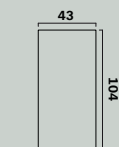

Quattro Pouf

Pouf con base in tubo d'acciaio curvato verniciato nero opaco e seduta imbottita in poliuretano a densità differenziata rivestito in pelli o tessuti di collezione.

/ Pouf with matt black painted curved steel tube frame and seat in polyurethane foam of different densities, covered in leather or fabric from our collection.

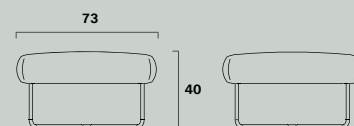

Quattro Pouf
Pouf
FG 518.00

Quattro CT

Set di tavolini fronte e fianco divano con struttura in tubo d'acciaio curvato verniciato colore nero opaco, ripiano in marmo. */ Set of side and coffee tables with matt black painted curved steel tube frame and marble top.*

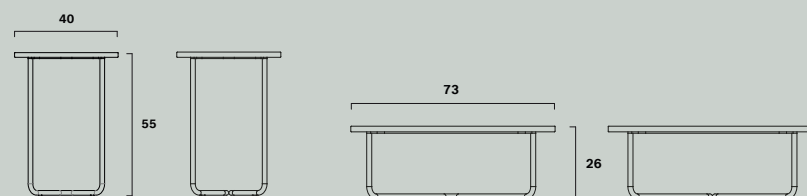

Quattro CT 55
Side Table
FG 518.51

Quattro CT 26
Coffee Table
FG 518.52

Otto

Letto composto da struttura e testata in legno multistrato imbottito e rivestito in pelle. Piedini in metallo verniciato in colore nero e puntali con finitura ottone spazzolato. */ Bed composed of a structure and a headboard in plywood, padded and covered in leather. Feet in black varnished metal and tips finished in brushed brass.*

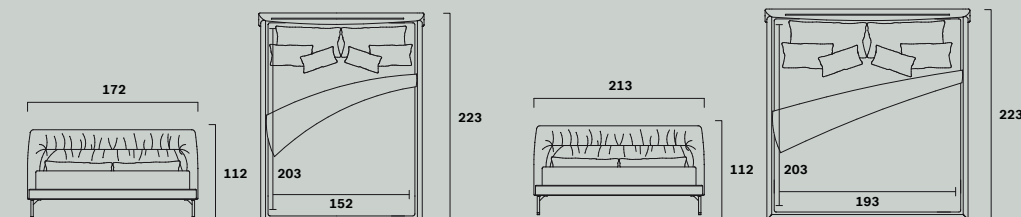

Otto Queen
Bed
FG 517.00
Mattress 1.52 × 2.03 m

Otto King
Bed
FG 517.01
Mattress 1.93 × 2.03 m

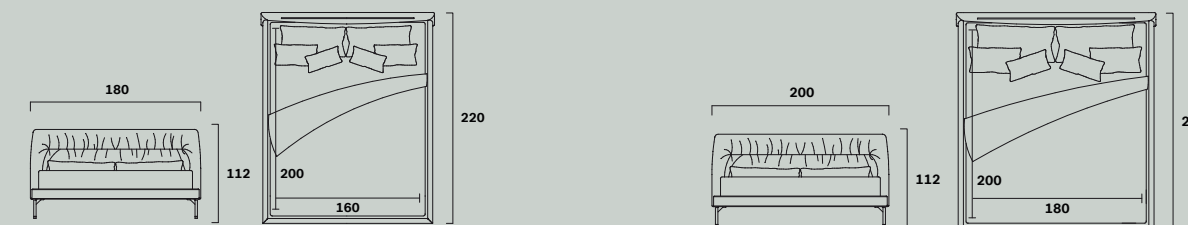

Otto 160
Bed
FG 517.04
Mattress 1.6 × 2 m

Otto 180
Bed
FG 517.05
Mattress 1.8 × 2 m

Twin

Collezione di specchi, ovale da terra e tondo a muro, con cornice in acciaio verniciato ottone spazzolato. */ Collection of mirrors including an oval floor version and a wall mounted round version with a brushed brass painted steel frame.*

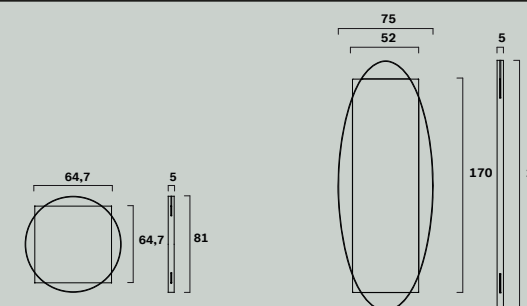

Twin One
Mirror
FG 524.00

Twin Duo
Mirror
FG 524.10

Colophon /Aknowledgements:

Company info

Frag Srl
Via dei Boschi 2
33040 Pradamano
Udine Italia
Tel. +39 0432 671375
frag@frag.it
www.frag.it

Credits

Art Direction
R+W

Concept and design
Choice—Studio

Moodboard drawings
Matteo Signorelli
Choice—Studio

Project coordination
Federica di Fonzo

Photos
Gionata Xerra Studio

Photo assistant
Leonardo Duggento

Concept & styling
Simona Silenzi Studio

Stylist Assistant
Gaia Marchesini

Photo retouching
Pierpaolo Mazzola

Color separation
Luce srl

Print
OGM SpA
Agosto 2021

Thanks to

Applicata
Artemide
Carpet Edition
Mmairo
Nemo
Oluce

The colour reproduced in the images, printed or in video, may differ from the actual colour of the material and should be regarded as a mere example. For a real comparison, we recommend using an original colour sample of the material.

Frag reserves the right to introduce any changes to its own models without prior notice. Color tones may vary from one dye lot to another.

© 2021 by Frag srl
All rights reserved

CATAS®



Frag
dal 1921

www.frag.it