

# degardo®

Timeless  
elegance:  
degardo.design objects  
for interior  
and exterior.



reddot award 2014  
winner



Made in Germany

# STORUS

# degardo®

Made in Germany

## STORUS

zeigt eine alternative Formensprache zu den marktüblichen Standards von runden und eckigen Pflanzgefäßen. Seine organisch anmutende Linienführung erinnert an Flusskiesel und fügt sich harmonisch in die Umgebung ein. Funktional stellt STORUS eine Kombination aus Gartenskulptur, Pflanzgefäß und Sitzobjekt dar. Es wird im Rotationsschmelzgussverfahren aus Polyethylen gefertigt und ist UV-, schlag- und witterungsbeständig. Je Größe stehen zwei Granit ähnliche Ausführungen sowie eine Version mit warm-weißer Beleuchtung zur Auswahl.

## STORUS

features an alternative design language to customary round and rectangular plant containers. Its organic lines are reminiscent of river gravel and blend in with the environment. With regards to function, STORUS is a combination of a garden sculpture, plant container and seating object. It is manufactured in polyethylene, employing a rotational moulding technique. It is UV, impact and weather resistant. Two granite-like finishes are available along with a version with warm-white lighting.



Bei 5 STORUS-Größen in jeweils 3 Farb-Ausführungen findet sich für jede Platzierung im In- und Outdoor-Bereich die richtige Version.

With 5 sizes and 3 colours, STORUS will always offer the right solution, both indoors and out, in any arrangement.



reddot award 2014  
winner

### Begründung der reddenot-Jury

»Auf hohem Niveau verbindet das Pflanzgefäß STORUS eine natürliche Ästhetik mit multifunktionalen Produkteigenschaften.«

### Statement by the reddenot-jury

»The Storus plant container combines a natural aesthetic with multifunctional product properties at a high standard.«



Abends entfalten die beleuchteten STORUS-Objekte eine einmalige Atmosphäre. Besonders in einem Gruppen-Arrangement, wie hier abgebildet.

In the evening, the illuminated STORUS unveils a unique atmosphere. Especially when arranged as a group, as shown here.



STORUS I

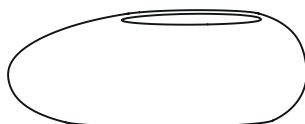

STORUS II



STORUS III



STORUS IV

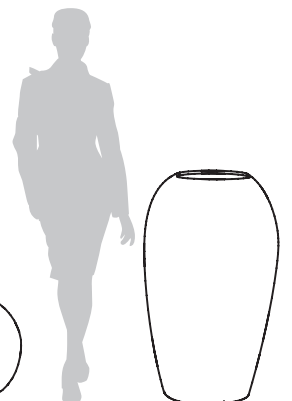

STORUS V

# STORUS I

STORUS I

Farbe transluzent beleuchtet  
Colour translucent illuminated

STORUS I

Farbe granit hell  
Colour light granite





STORUS I  
 Farbe granit dunkel  
 Colour dark granite



STORUS I  
 granit dunkel  
 dark granite  
 Art. 227654

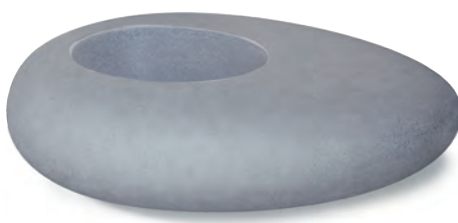

STORUS I  
 granit hell  
 light granite  
 Art. 227655



STORUS I  
 transluzent beleuchtet  
 translucent illuminated  
 Art. 227656



IP 66

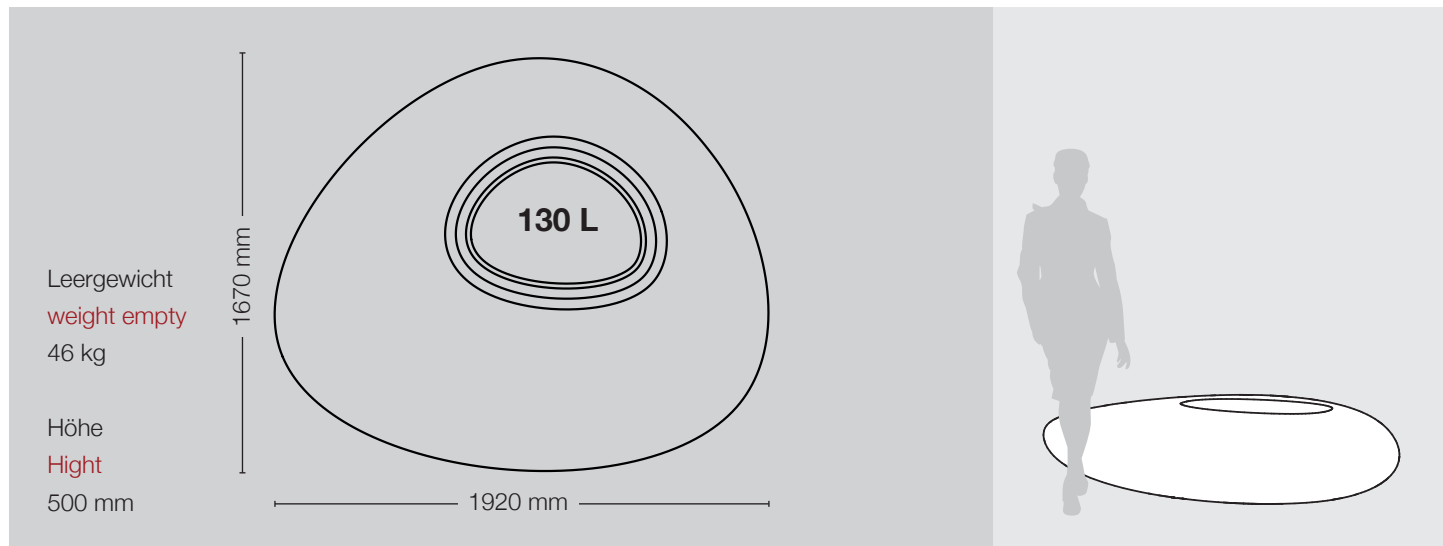

# STORUS II

STORUS II

Farbe transluzent beleuchtet /  
granit hell / granit dunkel  
Colour translucent illuminated /  
dark granite / light granite

STORUS II

Farbe granit hell  
Colour light granite





reddot award 2014  
winner



### STORUS II

Farbe transluzent beleuchtet  
Colour translucent illuminated



STORUS II  
granit dunkel  
dark granite  
Art. 221687



STORUS II  
granit hell  
light granite  
Art. 221688



STORUS II  
transluzent beleuchtet  
translucent illuminated  
Art. 221686



IP 66

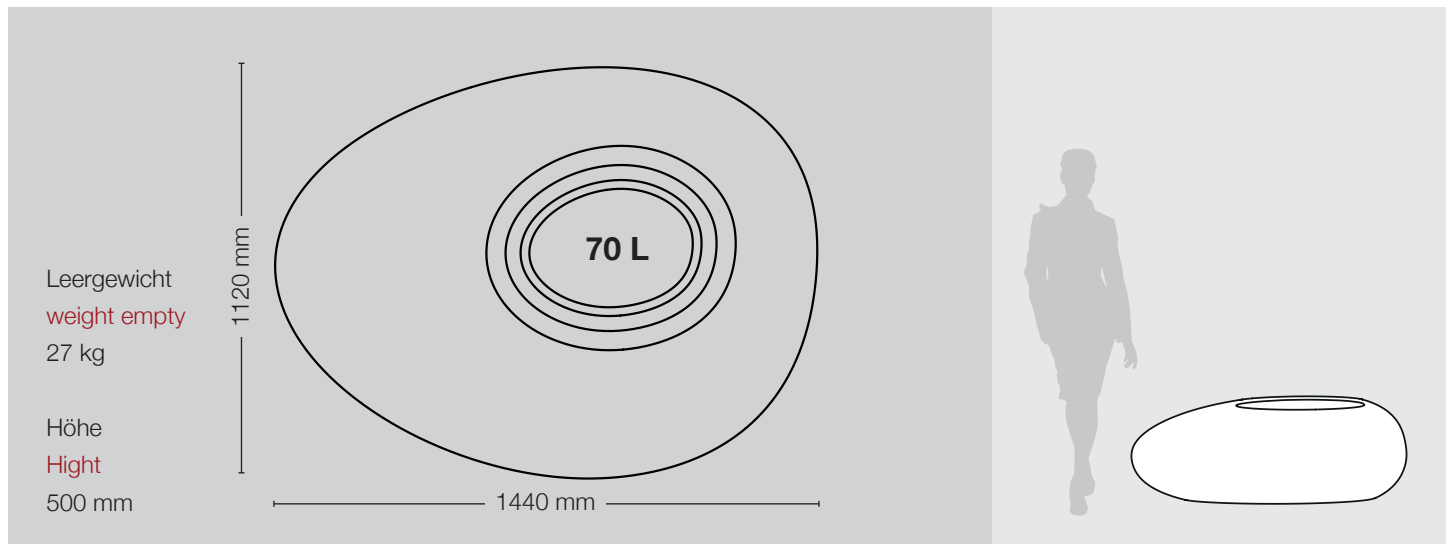

# STORUS III

STORUS III  
Farbe granit dunkel  
Colour dark granite

STORUS III  
Farbe granit hell  
Colour light granite







STORUS III

Farbe transluzent beleuchtet

Colour translucent illuminated



STORUS III

granit dunkel

dark granite

Art. 227661



STORUS III

granit hell

light granite

Art. 227662



STORUS III

transluzent beleuchtet

translucent illuminated

Art. 227663



IP 66

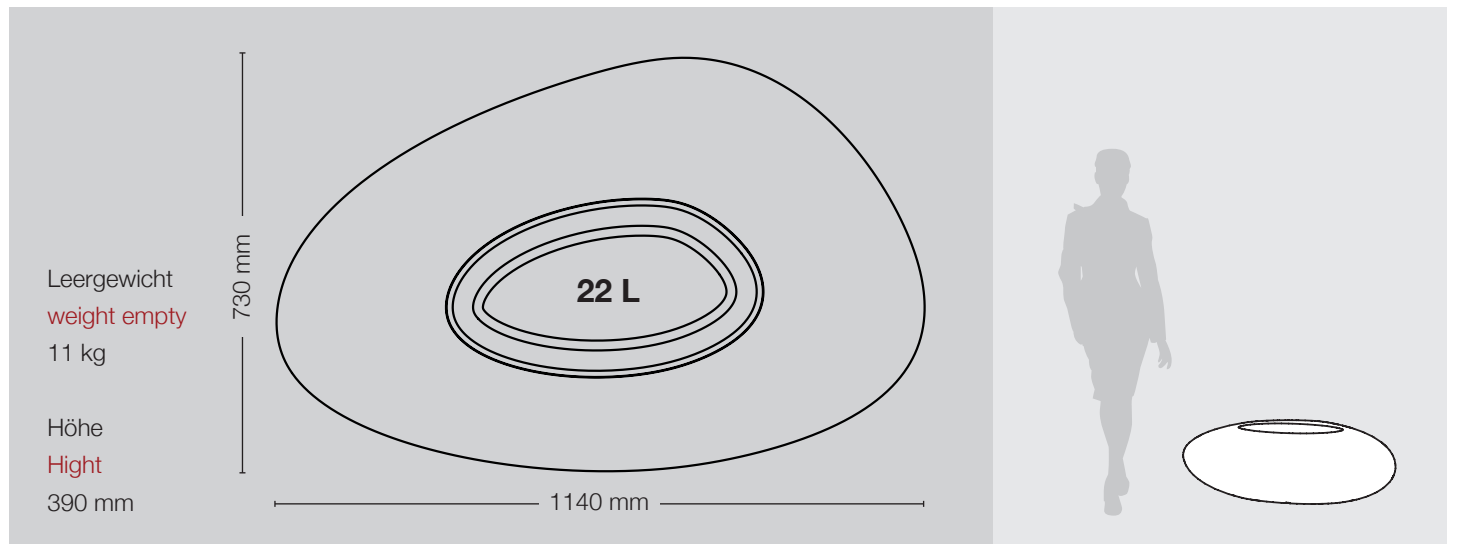

# STORUS IV

STORUS IV

Farbe transluzent beleuchtet  
Colour translucent illuminated

STORUS IV

Farbe granit dunkel  
Colour dark granite





STORUS IV  
 Farbe granit hell  
 Colour light granite



STORUS IV  
 granit dunkel  
 dark granite  
 Art. 227666



STORUS IV  
 granit hell  
 light granite  
 Art. 227667



STORUS IV  
 transluzent beleuchtet  
 translucent illuminated  
 Art. 227668



IP 66

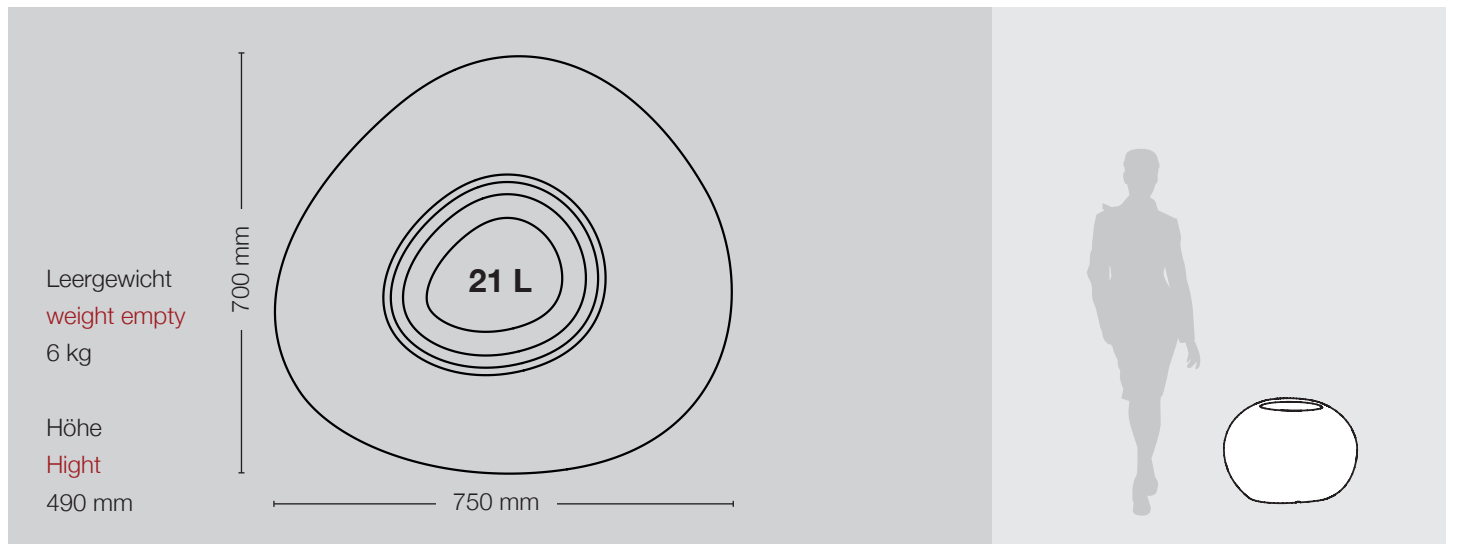

# STORUS V

STORUS V  
Farbe granit hell  
Colour light granite

STORUS V  
Farbe transluzent beleuchtet  
Colour translucent illuminated





STORUS V

Farbe granit dunkel

Colour dark granite



STORUS V

granit dunkel

dark granite

Art. 227671



STORUS V

granit hell

light granite

Art. 227672



STORUS V

transluzent beleuchtet

translucent illuminated

Art. 227673



IP 66

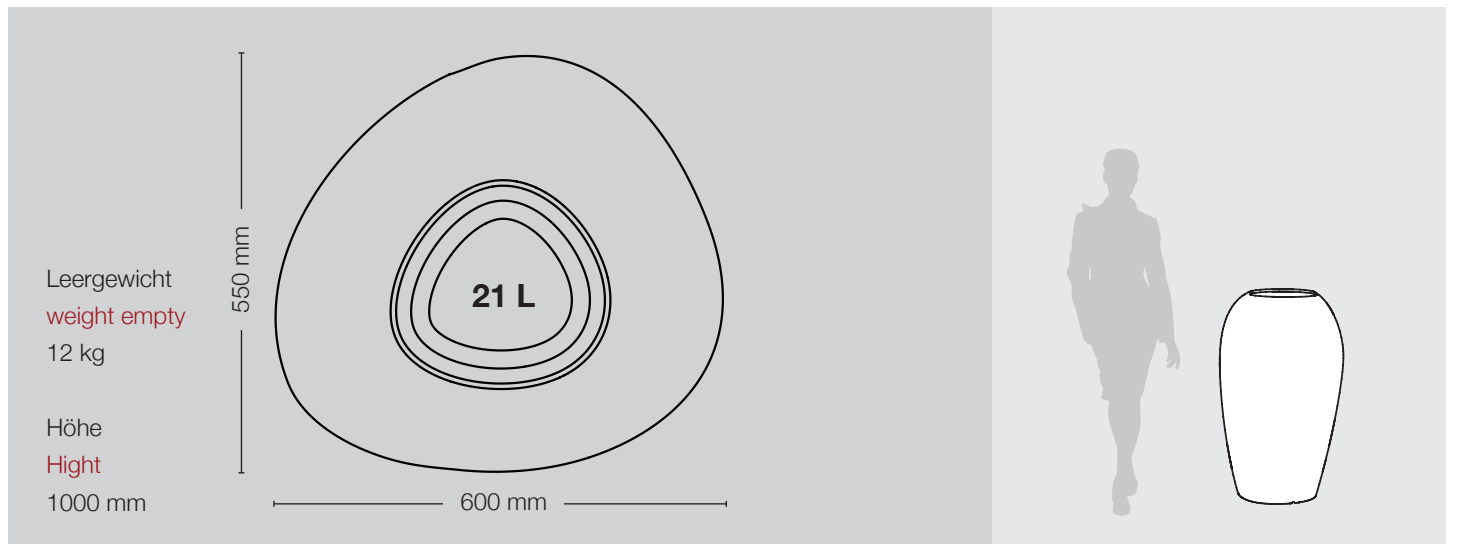

# degardo®



## Beständig und langlebig

STORUS-Produkte können Indoor und Outdoor eingesetzt werden. Durch hochwertiges, reines Polyethylen (PE) sind sie: witterungsbeständig, schlagfest, UV-stabil und temperaturbeständig von -45 °C bis +75 °C.

Selbst Säuren und Hochdruck-Reiniger sind kein Problem. Reines PE ist 100% recyclebar.

## Resistant and long lasting

STORUS can be used both indoors and outdoors. The use of high quality, pure polyethylene (PE) ensures they are resistant to weather, impacts and UV light and are suitable for use from -45 °C to +75 °C.

Even acids and high pressure cleaners are not a problem. Pure PE is 100% recyclable.



## Hohe Materialstärke

Alle STORUS-Gefäße werden mit einer soliden Materialstärke von bis zu 10 mm gefertigt.

Diese bei Pflanzgefäßen ungewöhnliche Dicke gewährleistet auch langfristig eine hohe Nutzungsqualität und Schlagfestigkeit. Selbst der Einsatz als Sitzobjekt ist bei STORUS I und II problemlos möglich.

## High material strength

All STORUS containers have a sturdy material thickness of up to 10 mm. This unusual thickness of material for a planting container means that they are both long lasting and resist impacts, while ensuring a high quality of use.

STORUS I and II can even be used as a seat.



## Doppelwandiger Aufbau

Alle STORUS-Größen sind grundsätzlich doppelwandig konstruiert. Der Hohlraum zwischen Außenwandung und Pflanzbereich bietet dem Wurzelwerk der Pflanzen einen optimalen Thermo-Schutz gegen Frosteinfluss. Die Frostwirkung wird deutlich reduziert und verzögert.

## Double walled construction

All STORUS sizes have a double-walled construction. The hollow space between the outer wall and the container planting area ensures optimum frost protection for the roots of your plants. Frost damage is significantly reduced and delayed.



## Direkte Außenentwässerung (Outdoor-Einsatz)

Jeder Pflanzbereich ist mit einer Pfeilmarkierung versehen. Ein Durchbohren (Ø 10 mm) an exakt dieser Stelle ermöglicht den direkten Ablauf von überschüssigem Wasser nach Außen. Kein Altwasser im Hohlraum. Keine optischen oder bakteriellen Veränderungen.

## Direct drainage (Outdoor use)

Each planter has an arrow marker on it. Drilling a hole (Ø 10 mm) at this exact point allows excess water to drain directly to the outside. No stagnant water will collect in the hollow centre. There are no bacterial changes and the planter's appearance is not altered.



## Hochwertige Beleuchtungselemente

Die beleuchteten STORUS-Varianten aus transluzentem Polyethylen sind mit E27 Energiesparlampen (warm-weiß) ausgestattet. Rostfreie Edelstahlverschraubungen und Dichtungen am Produktboden garantieren Langlebigkeit und einen Allwetter-Einsatz nach IP 66. Inklusive 5 m Anschlusskabel in Outdoor-Qualität.

## Quality lighting

The illuminated STORUS models in translucent polyethylene are fitted with E27 energy saving bulbs (warm-white). Stainless steel screwed fittings and seals on the product base ensure long life and all-weather use and meet IP 66. Includes 5 m power cable suitable for outdoor use.

# Details und Zubehör

## Details and accessories



### Pflanzeinsatz

Individuell für jedes STORUS-Modell.  
Zum saisonalen Wechsel der Bepflanzung.  
Zum einfachen Versetzen der Gefäße.

I Art. 227657	IV Art. 227669
II Art. 227659	V Art. 227674
III Art. 227664	

### Planter insert

To suit each STORUS model.  
For seasonal planting variation.  
For easy container filling.

I Art. 227657	IV Art. 227669
II Art. 227659	V Art. 227674
III Art. 227664	



### Dekoeinsatz

Individuell für jedes STORUS-Modell.  
Zur vielseitigen Verwendung, z.B. als  
Eiskübel-Einsatz. Translucent, hinterleuchtbar.

I Art. 227658	IV Art. 227670
II Art. 227660	V Art. 227675
III Art. 227665	

### Decorative insert

To suit each STORUS model.  
Multi-purpose use eg for ice cubes.  
Translucent, for use with backlighting.

I Art. 227658	IV Art. 227670
II Art. 227660	V Art. 227675
III Art. 227665	



### Tischplatte

Macht STORUS III und IV  
zu einem attraktiven Lounge-Tisch.  
In anthrazit oder weiß.

III weiß	Art. 227771
III anthrazit	Art. 227772
IV weiß	Art. 227773
IV anthrazit	Art. 227774

### Table top

Makes STORUS III and IV  
an attractive lounge table.  
In anthracite or white.

III white	Art. 227771
III anthracite	Art. 227772
IV white	Art. 227773
IV anthracite	Art. 227774



### Diebstahl- / Standsicherung

Universell für alle STORUS-Größen.  
Verhindert unbefugte Mitnahme. Als Boden-  
anker (Abb.) sowie Schraub- oder Klebevari-  
ante verfügbar.

Bodenanker	Art. 205669
Bodenplatte, schrauben	Art. 227676
Bodenplatte, kleben	Art. 227677

### Prevents theft, ensures stability

Suitable for all STORUS sizes.  
Prevents unauthorised removal. Available with  
ground anchor (see image) or with bolted or  
adhesive version.

Ground anchor	Art. 205669
Ground plate, bolt	Art. 227676
Ground plate, adhesive	Art. 227677



### Spezialreiniger

Optimiert zur effektiven und nachhaltigen Reini-  
gung aller DEGARDO-Produkte im In- und Out-  
doorbereich. Unverdünnt aufsprühen oder mit  
einem Tuch auftragen. Rückstände mit einem  
fusselfreien Tuch entfernen. Biologisch abbau-  
bar. Verfügbar in der 1L-Sprühflasche.  
Art. 227679

### Special cleaner

Optimised for effective, long lasting cleaning  
of all DEGARDO products, both indoors and  
outdoors. Spray on or apply with a cloth, wi-  
thout diluting. Use a lint-free cloth to remove  
any residue. Bio-degradable.  
Available in a practical 1 litre spray bottle.  
Art. 227679

Zeitlos elegant: Designobjekte für innen und außen.



Timeless elegance: design objects for interieur and exterieur.

DEGARDO GmbH  
Dehmer Straße 66  
32549 Bad Oeynhausen  
Germany

Phone +49 5731 753-300  
Fax +49 5731 753-95-300  
info@degardo.de  
www.degardo.de