

2 Schränke | Kredenzen | Truhen

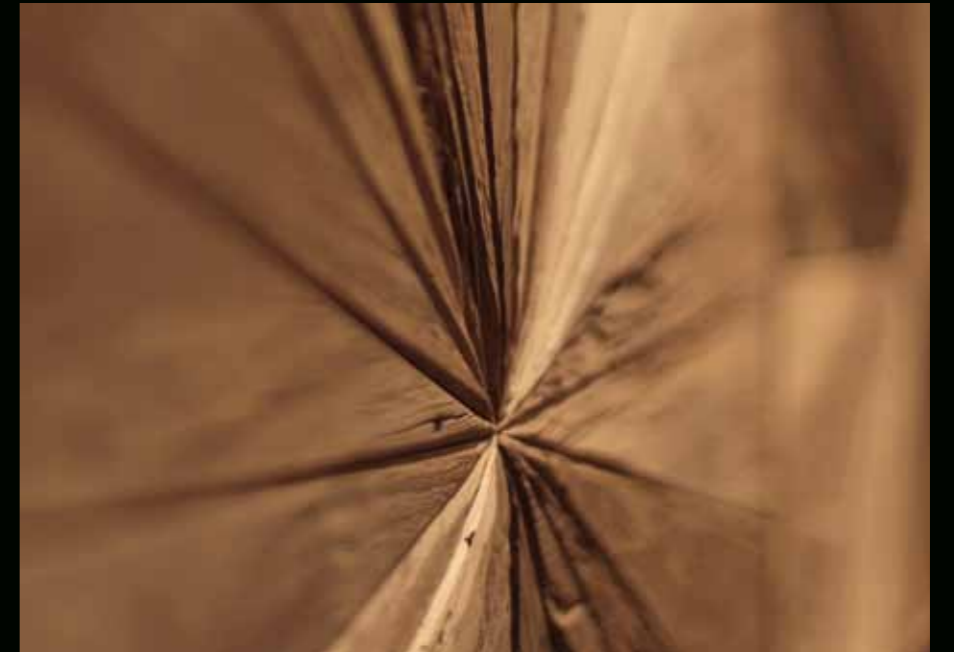



INNENLEBEN - ECHTE HANDWERKSQUALITÄT







Schrank 2-türig «Life»
60-101-SU
H 190 B 179 T 61 cm
Korpus Lack elfenbein
Sonnenstrahlen Sumpfeiche



Lack nach RAL-Farben
möglich





Schrank 2-türig «Life»
60-101-EABG
H 190 B 179 T 61 cm
Korpus Lack elfenbein / schwarz
Sonnenstrahlen Eiche antik Balkenschnitt

Kredenz 2-türig mit 4 Schubladen «Life»

60-123-M
H 95 B 197 T 50 cm

Schrank 1-türig «Life»

60-100-M
H 190 B 105 T 61 cm

Korpus und Sonnenstrahlen Sumpfeiche





Dekogehänge
60-101-D



Schrank 2-türig «Life»
60-101-M
H 190 B 179 T 61 cm
Korpus und Sonnenstrahlen Sumpfeiche



Schrank 1-türig «Life»

60-100-STI
H 190 B 105 T 61 cm

Kredenz 2-türig mit 4 Schubladen «Life»

60-123-STI
H 95 B 197 T 50 cm

Schrank 2-türig «Life»

60-101-STI
H 190 B 179 T 61 cm

Korpus und Stirnholz Sumpfeiche





Schrank 2-türig «Edelweiss»

12-8105
H 165 B 100 T 53 cm

Kredenz 4-türig «Edelweiss»

12-8106
H 85 B 200 T 50 cm

*Korpus und Türe Sumpfeiche
Türeinlage Etrusker Keramik oder Sumpfeiche*





Kredenz 2-türig mit 4 Schubladen «Arte»
38-7004
H 77 B 150 T 47 cm
Korpus Sumpfeiche
Front Sumpfeiche und Eiche antik Balkenschnitt
Schubladen Sumpfeiche und Eiche antik Balkenschnitt

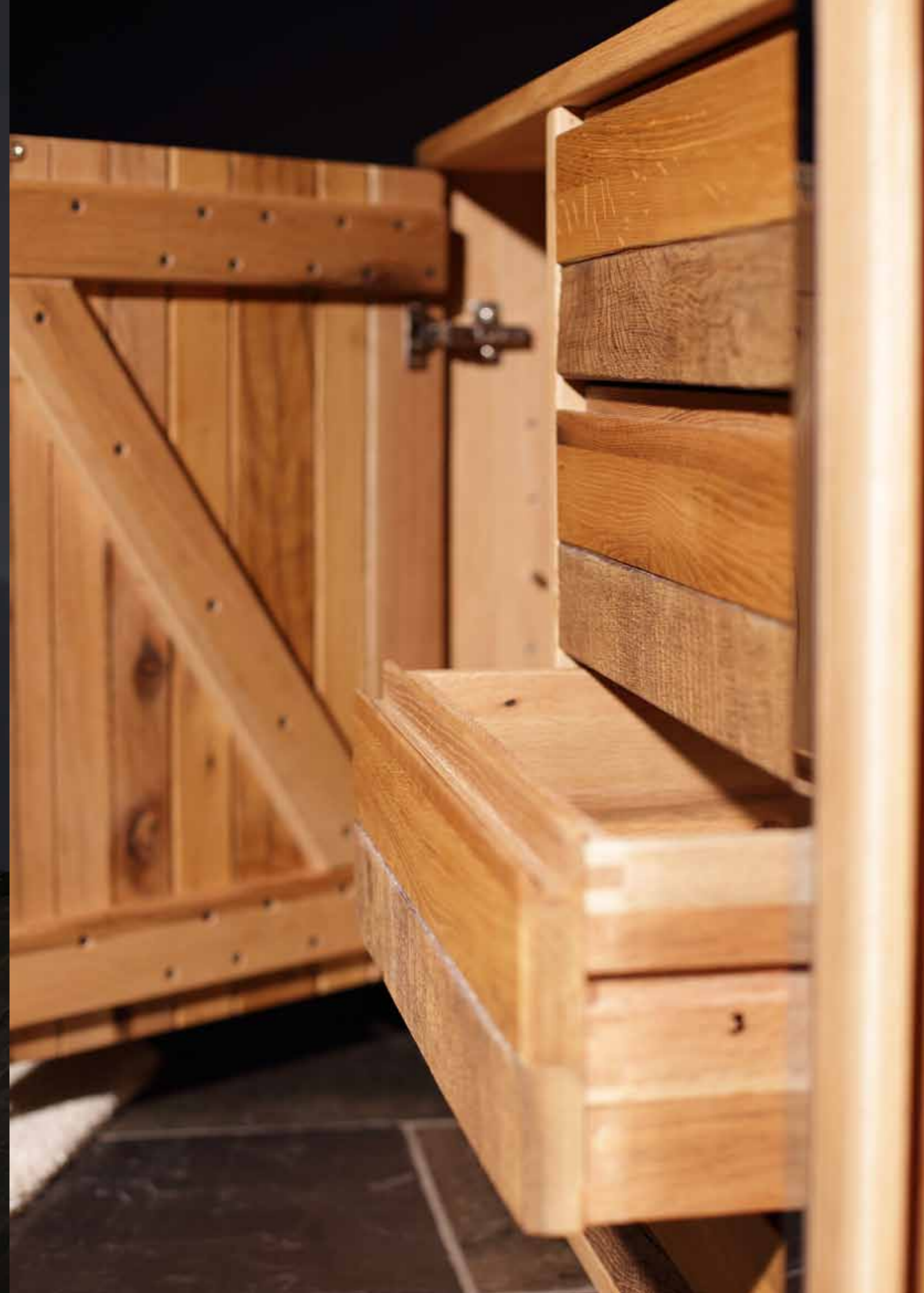

Kredenz 4-türig «Arte»
38-7005
H 77 B 200 T 47 cm
Korpus und Front Sumpfeiche
auch 2- und 3-türig erhältlich



Kredenz 4-türig «Arte»

38-7005
H 77 B 200 T 47 cm
Korpus Arve (Zirbe)
Front Glas weiss mit Waldkante

auch 2- und 3-türig erhältlich



Kredenz 2-türig mit 4 Schubladen «Arte»

38-7004
H 77 B 150 T 47 cm
Korpus Sumpfeiche
Front Glas weiss mit Waldkante
Schubladen Sumpfeiche und Eiche antik Balkenschnitt

Kredenz 4-türig hoch «Arte»

38-7005

H 77 B 200 T 47 cm

Korpus Sumpfeiche

Front Glas weiss mit Waldkante

auch 2- und 3-türig erhältlich





Schloss in Holz
22-216-HS

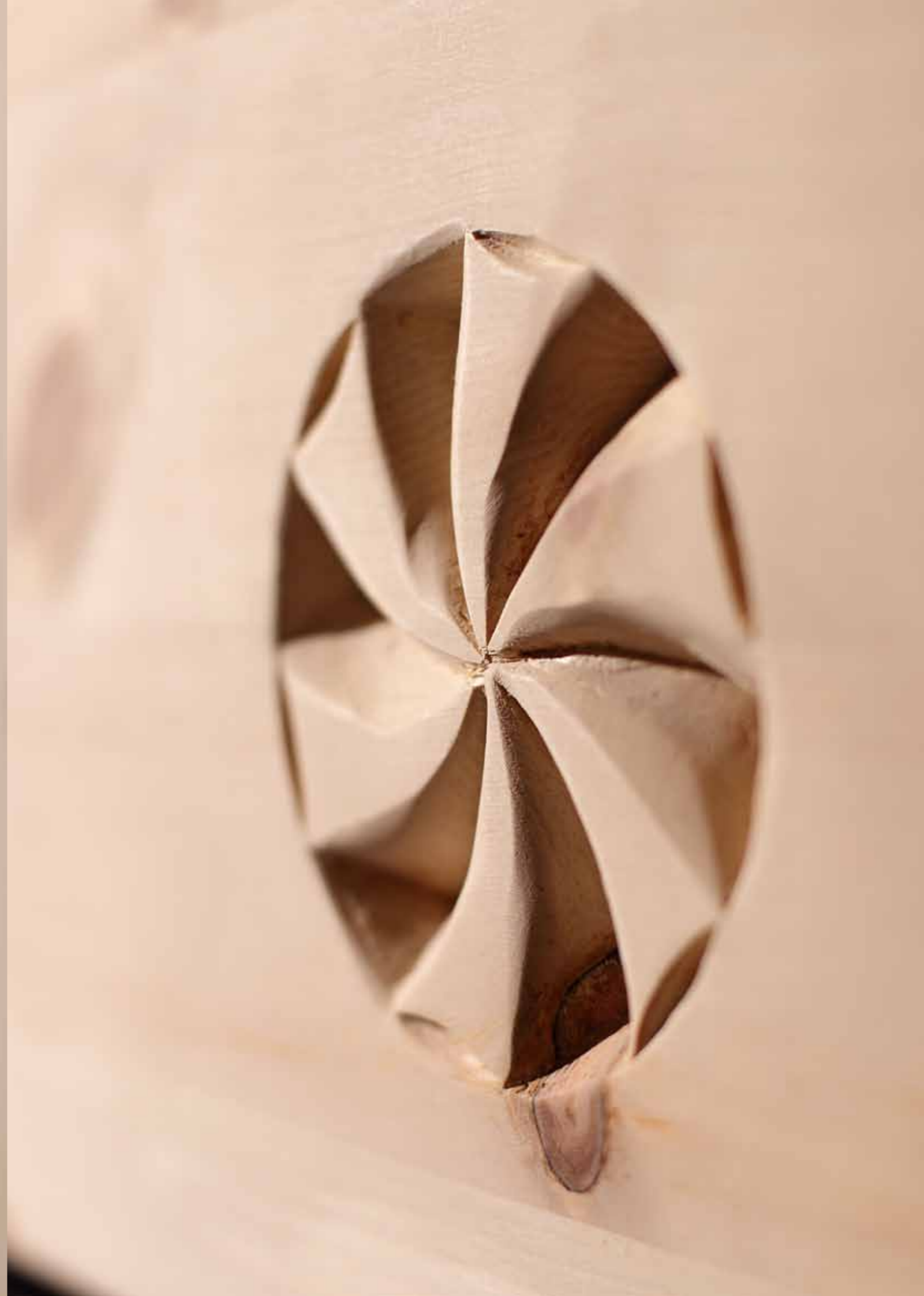

Schrank 1-türig nieder «Engadin»

22-216
H 130 B 90 T 45 cm
Schloss in Holz

Schrank 1-türig «Engadin»

22-214
H 170 B 90 T 45 cm

Arve (Zirbe)

Stehlampe Legno

12-43

Sessel Salzburg

36-5335





Die Arve (Zirbe) - Gesund im Schlaf

Der Mythos, mit dem die Arve - die Königin der Alpen - behaftet ist, hat seine guten Gründe. Es ist nicht nur die Gemütlichkeit, die das Holz ausstrahlt, sondern es sind auch die vielen zusätzlichen positiven Eigenschaften.

Wissenschaftliche Studien kommen zu interessanten Ergebnissen. Das **Raumklima** wird gleichmässig **positiv beeinflusst**. **Wohlbefinden und Gesundheit** wird nachhaltig angeregt und gefördert.

«Im Arvenholz-Bett schläft sich's besser!»

Es zeigt sich eine **deutlich bessere Schlafqualität**. **Die bessere Nachterholung geht mit einer reduzierten Herzfrequenz und einer erhöhten Schwingung des Organismus im Tagesverlauf einher**. Die durchschnittliche **Ersparnis** im Arvenholzbett liegt bei 3500 Herzschlägen pro Nacht, das entspricht **ca. einer Stunde «Herzarbeit»**. Die Herzfrequenz ist ein wichtiger Indikator für die Lebenserwartung.

Wissenschaftlich belegt ist auch die Tatsache, dass **in einem Arvenzimmer keine Wetterfühligkeit** auftritt. Trotz Luftdruckänderung bleibt der Kreislauf stabil. Das Material der Wohnungseinrichtung hat offensichtlich grössere Auswirkungen auf Wohlbefinden und Gesundheit als bisher bekannt. Die Natur gibt vor, nach welcher Linie man sich orientieren soll: **Lebensstil beginnt im Kopf**.

Truhe mit Klappe «Engadin»

22-202
H 65 B 120 T 50 cm

Kredenz 2-türig «Engadin»

22-211
H 85 B 140 T 45 cm
Ablage in Andeerer Granit

Stehlampe Montana

12-30R

Arve (Zirbe)



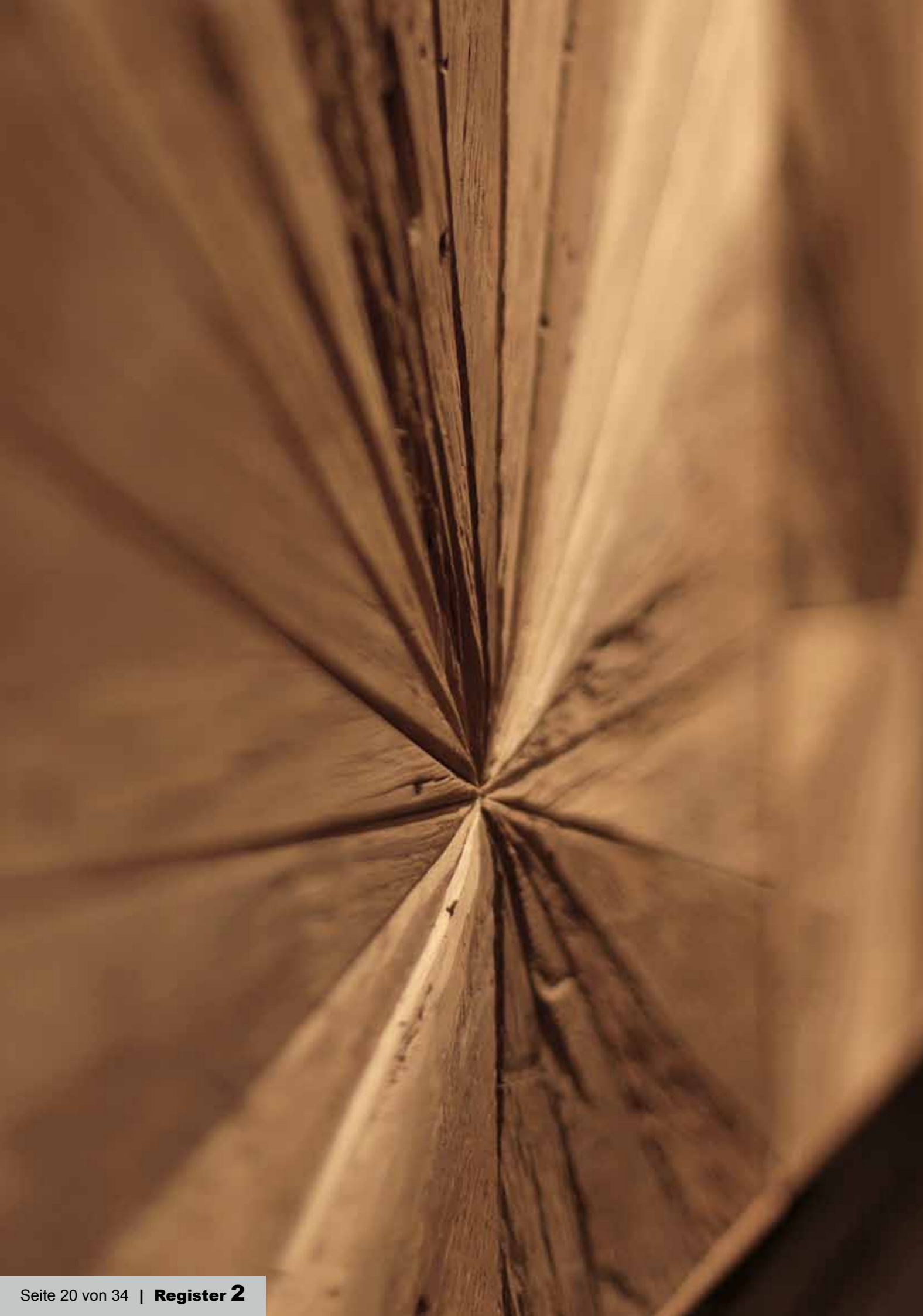

Kredenz 4-türig «Vinci»
12-5
H 69 B 240 T 45 cm
Korpus Lack schwarz
Front Eiche antik - Balkenschnitt



Kredenz 4-türig «Vinci»

12-5
H 69 B 240 T 45 cm

Kredenz 3-türig «Vinci»

12-6
H 69 B 181 T 45 cm

*Korpus Sumpfeiche
Front Eiche antik - Balkenschnitt*

auch 2-türig erhältlich

Spezialanfertigungen auf Anfrage möglich

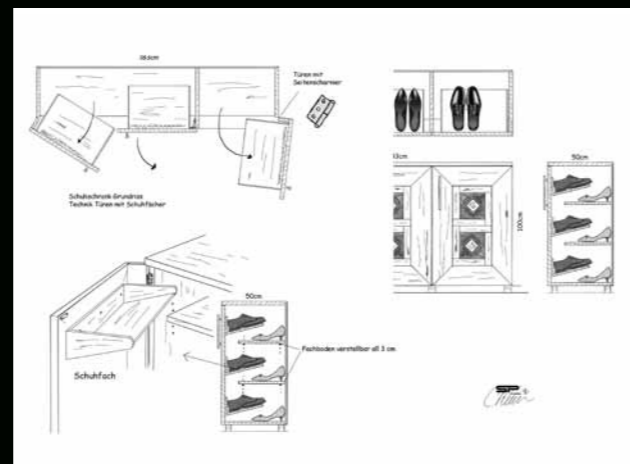
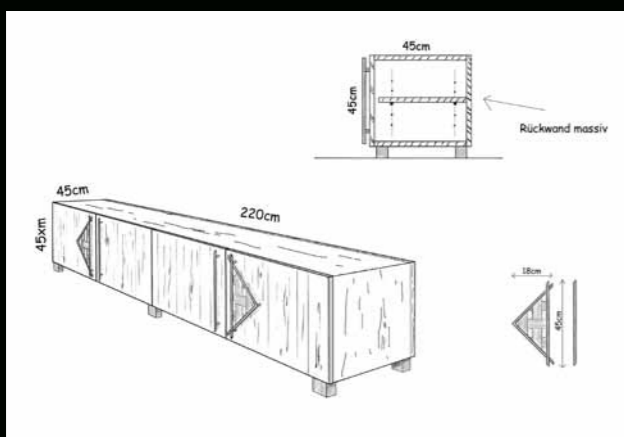
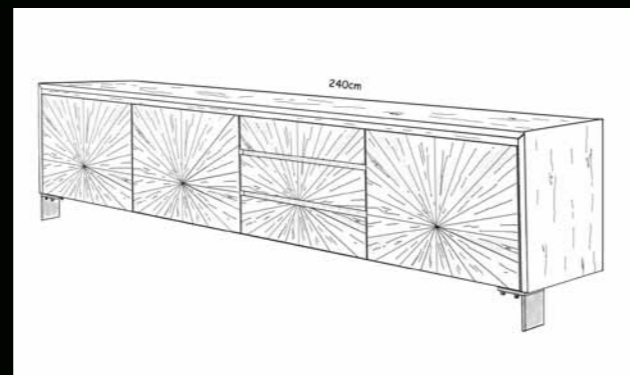
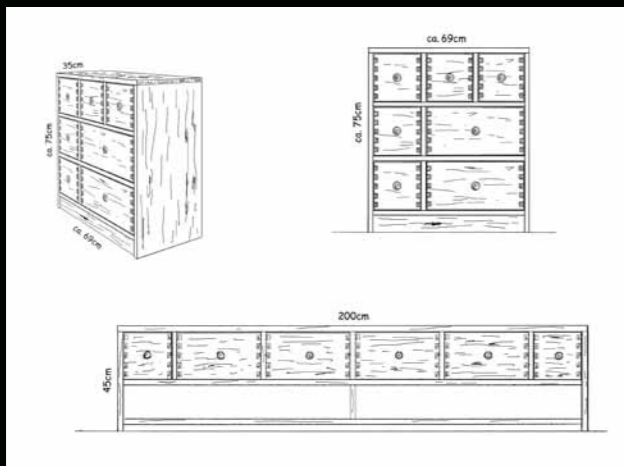
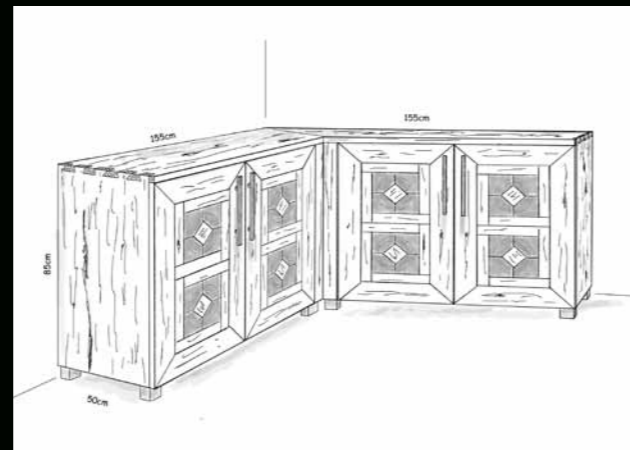

Kredenz 3-türig «Nobile»
N3-S-S
H 65 B 180 T 45 cm
Korpus und Front in Sumpfeiche
Kufenfuss in Eisen vernickelt
Holzgriff klein



Kredenz 3-türig «Nobile»
N3-E-E
H 65 B 180 T 45 cm
Korpus und Front Eiche naturschwarz
Kufenfuss Eisen vernickelt
Holzgriff klein



Schrank «Nobile»
N1-S-S
H 165 B 100 T 45 cm
Korpus und Front Sumpfeiche
Fuss seitlich Eisen vernickelt
Holzgriff gross



Schrank «Nobile»

N1-E-QS

H 165 B 100 T 45 cm

Fuss seitlich Eisen vernickelt

Kredenz 3-türig «Nobile»

N3-E-QS

H 65 B 180 T 45 cm

Kufenfuss Eisen vernickelt

Korpus Eiche naturschwarz

Front Quarzsand-Malerei rot

Eisengriff vernickelt



Kredenz 3-türig «Nobile»
N3-E-QB
H 65 B 180 T 45 cm

Schrank «Nobile»
N1-E-QB
H 165 B 100 T 45 cm

*Korpus Eiche naturschwarz
Front Quarzsand-Malerei beige
Kufenfuss Eisen vernickelt
Eisengriff vernickelt*



Schrank «Nobile»

N1-E-QG
H 165 B 100 T 45 cm

Kredenz 3-türig «Nobile»

N3-E-QG
H 65 B 180 T 45 cm

*Korpus Eiche naturschwarz
Front Quarzsand-Malerei grauschwarz
Kufenfuss Eisen vernickelt
Eisengriff vernickelt*





Schrank «Nobile»

N1-S-30
H 165 B 100 T 45 cm

Kredenz 4-türig «Nobile»

N4-S-30
H 65 B 240 T 45 cm

*Korpus Sumpfeiche
Front Glas weiss
Waldkante
Kufenfuss Holz
Schloss Holz*

Hockerlampe

12-37





Schrank «Nobile»

N1-NU-30
H 165 B 100 T 45 cm

Kredenz 4-türig «Nobile»

N4-NU-30
H 65 B 240 T 45 cm

*Korpus Nussbaum
Front Glas weiss
Waldkante
Kufenfuss Holz
Schloss Holz*





Schrank «Nobile»

N1-S-SO
H 165 B 100 T 45 cm

Kredenz 3-türig «Nobile»

N3-S-SO
H 65 B 180 T 45 cm

*Korpus Sumpfeiche
Front Sonne
Kufenfuss Holz
Holzgriff klein*

Hockerlampe

12-37



Ich bin Schönheit von Natur aus.

